

$$\alpha_V > \alpha_H$$

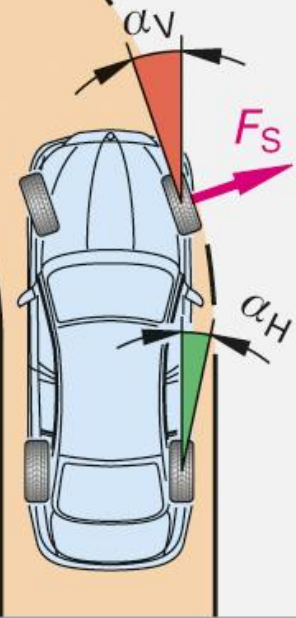

$$\alpha_H > \alpha_V$$

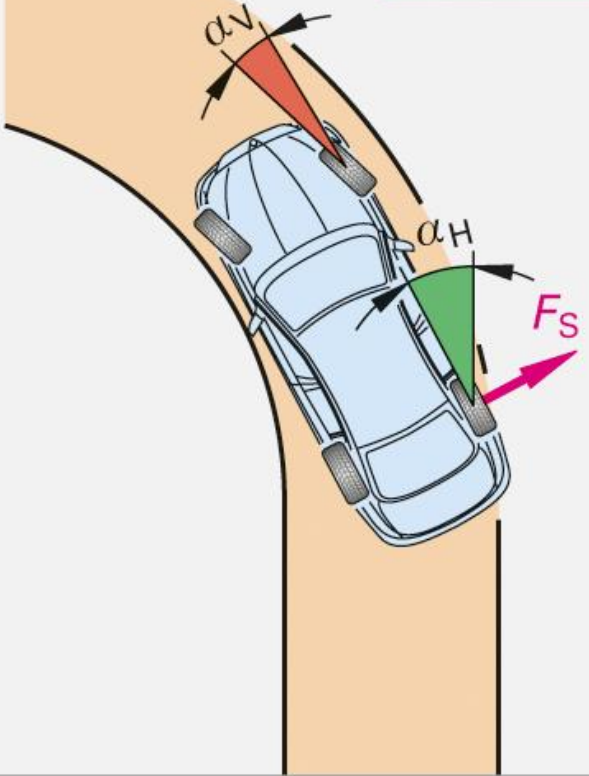

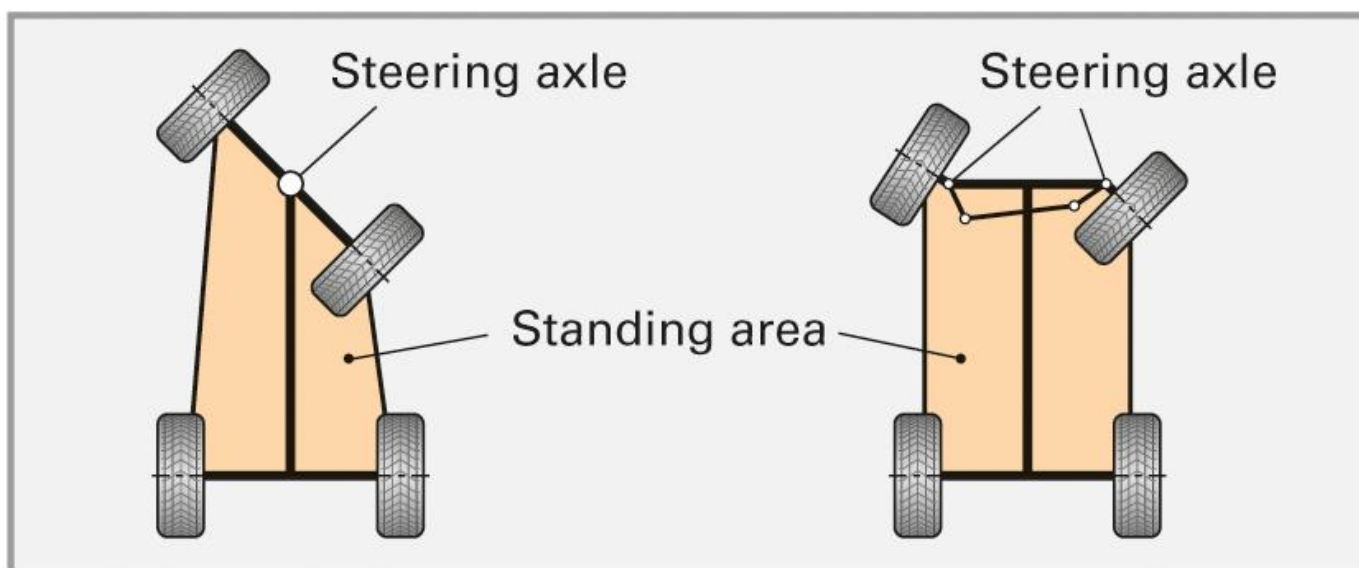
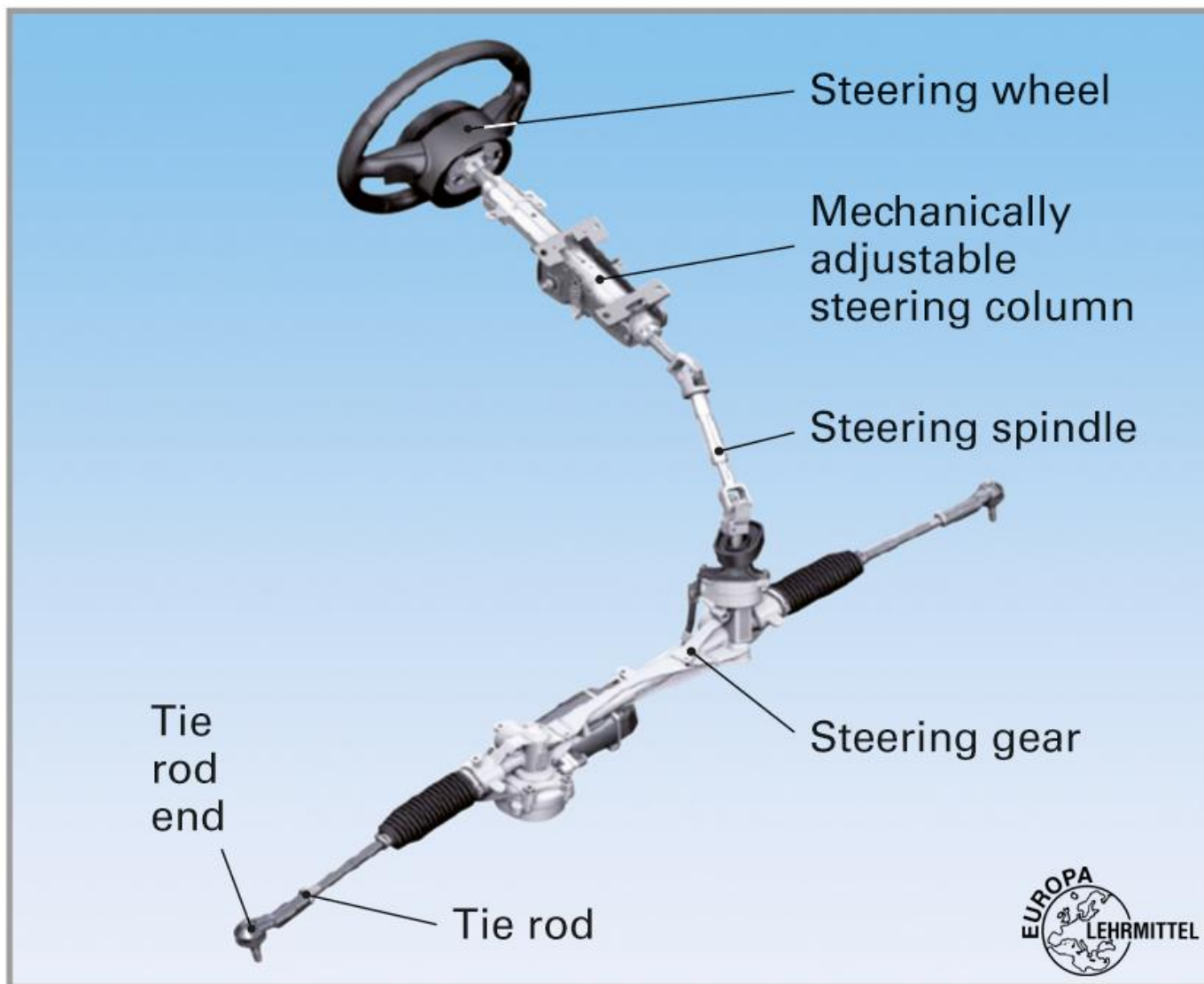

δ Toe difference \sphericalangle
 α, β Wheel angle \sphericalangle

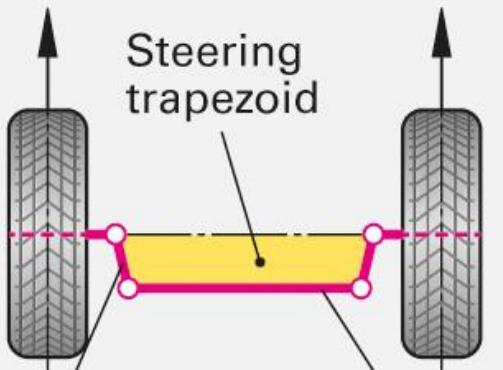
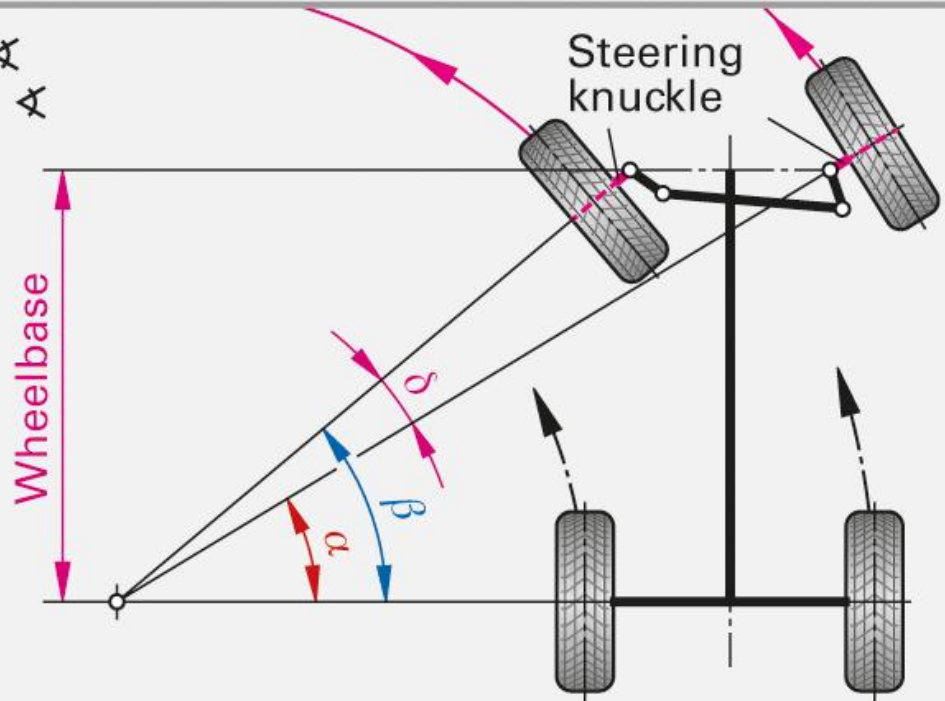

Tie rod arm Tie rod

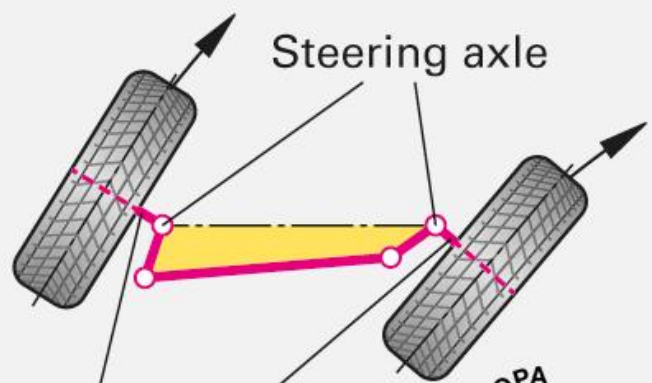

Steering knuckle



