

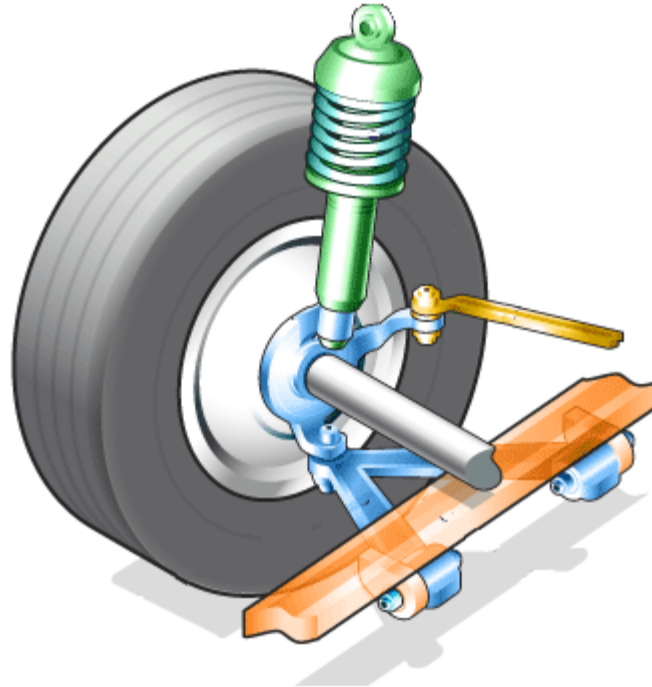

ÍÐAN  
fræðslusetur  
Bilgreinasvið

# Fjöðrunarbúnaður





## Kynning

- Kennari
- GSM, vinsamlega slökkvið á sínum
- Hlé
- Salerni
- Flóttaleiðir
- Reykingar





## Undirstöðuatriði

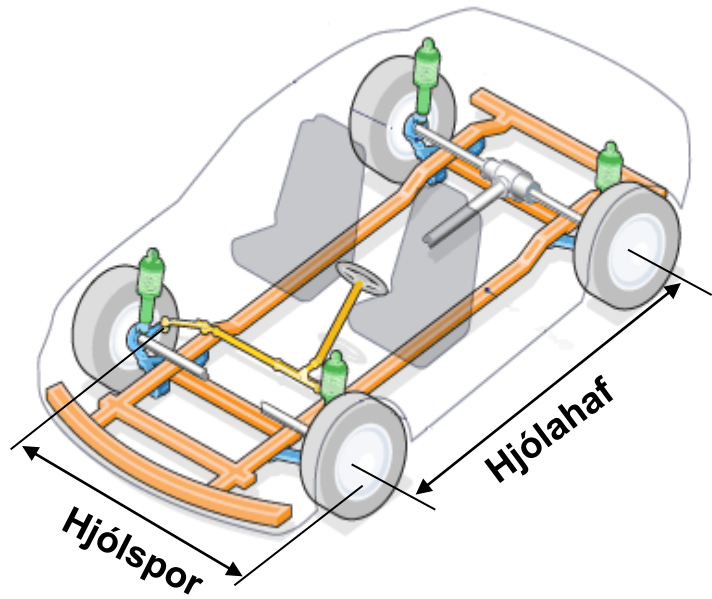

Breyting á álagi hjólbarða

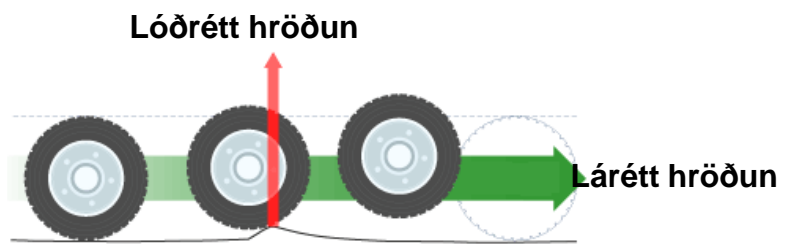

Veggríp losnar

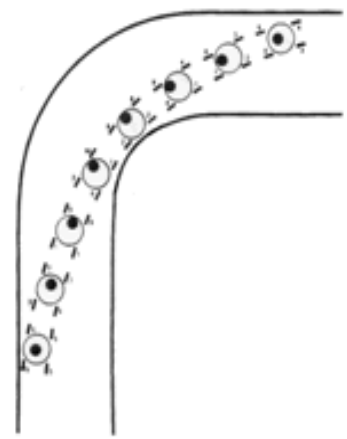

Bifreið beygt



## Fjöðrunarkerfið



Án fjöðrunarkerfis



Með gormun, en engum höggdeyfum



Með gormum og höggdeyfum



Akstursstjórnun

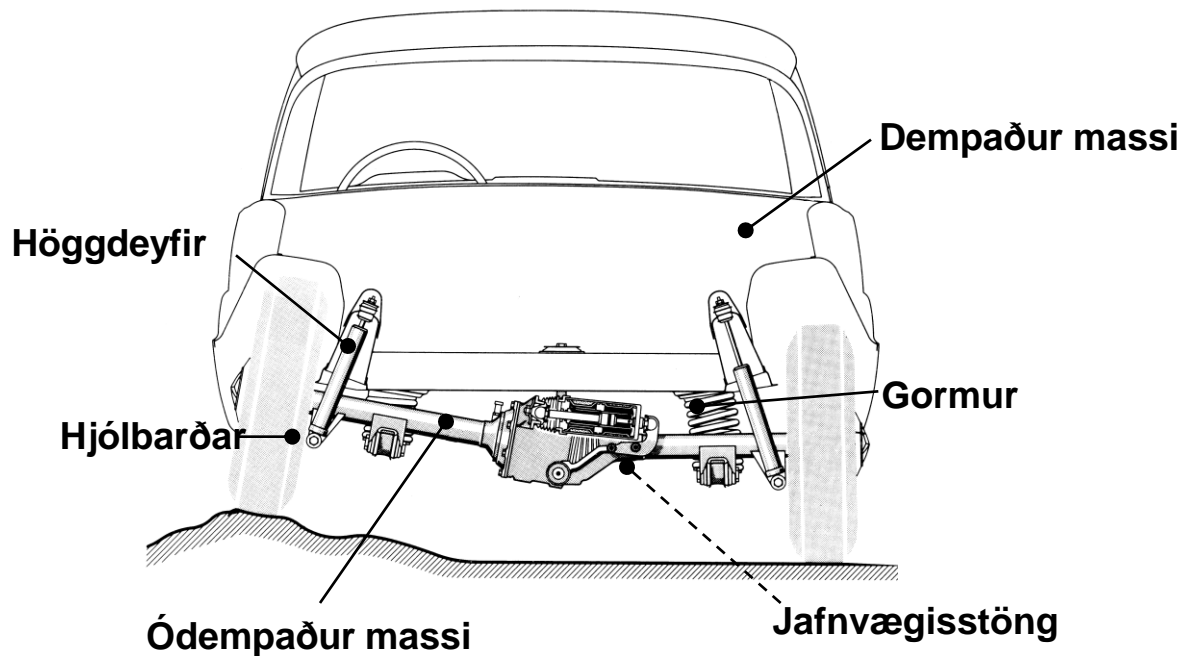



## Fjöðrun

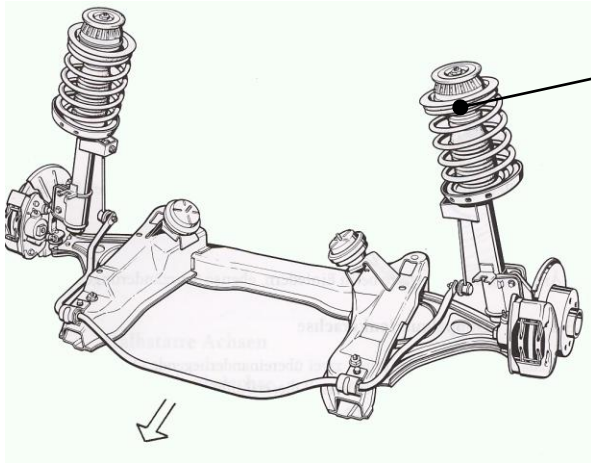

Gormar

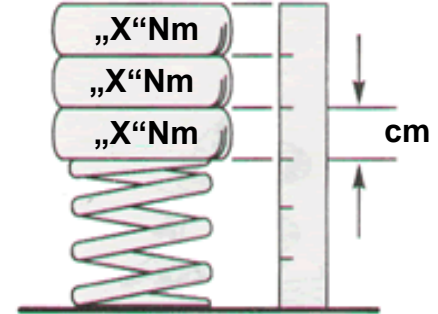
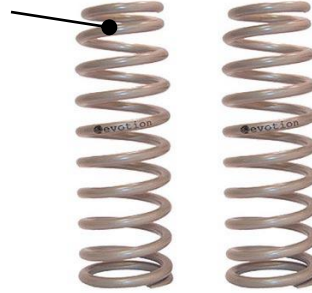

Fjöðrun

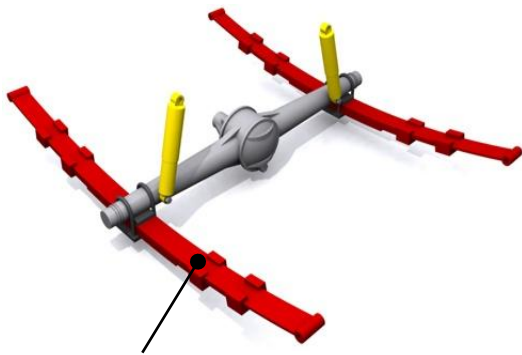

Blaðfjaðrir



Loftpúða fjöðrun



## Virgni höggdeyfa

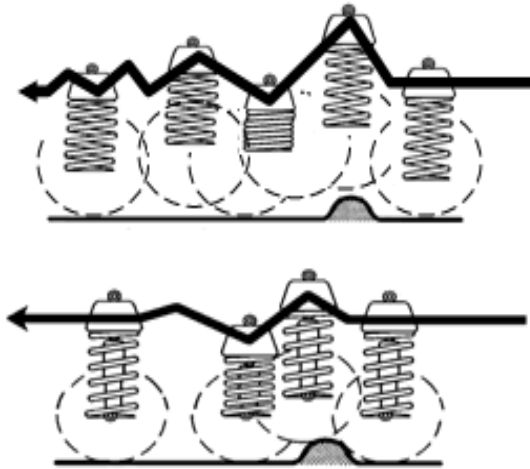

## Tilgangur höggdeyfis

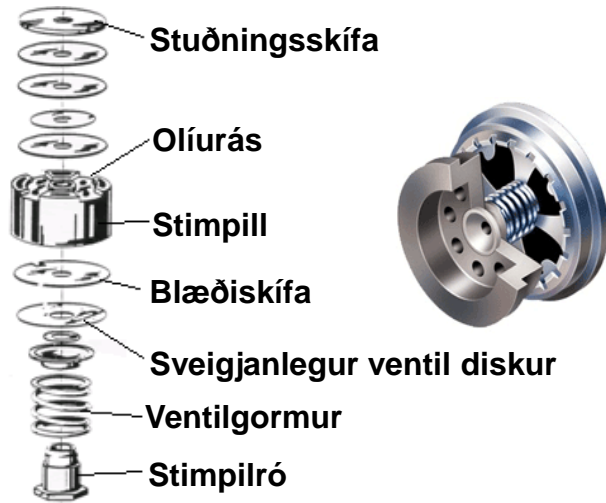

## Grunnventill

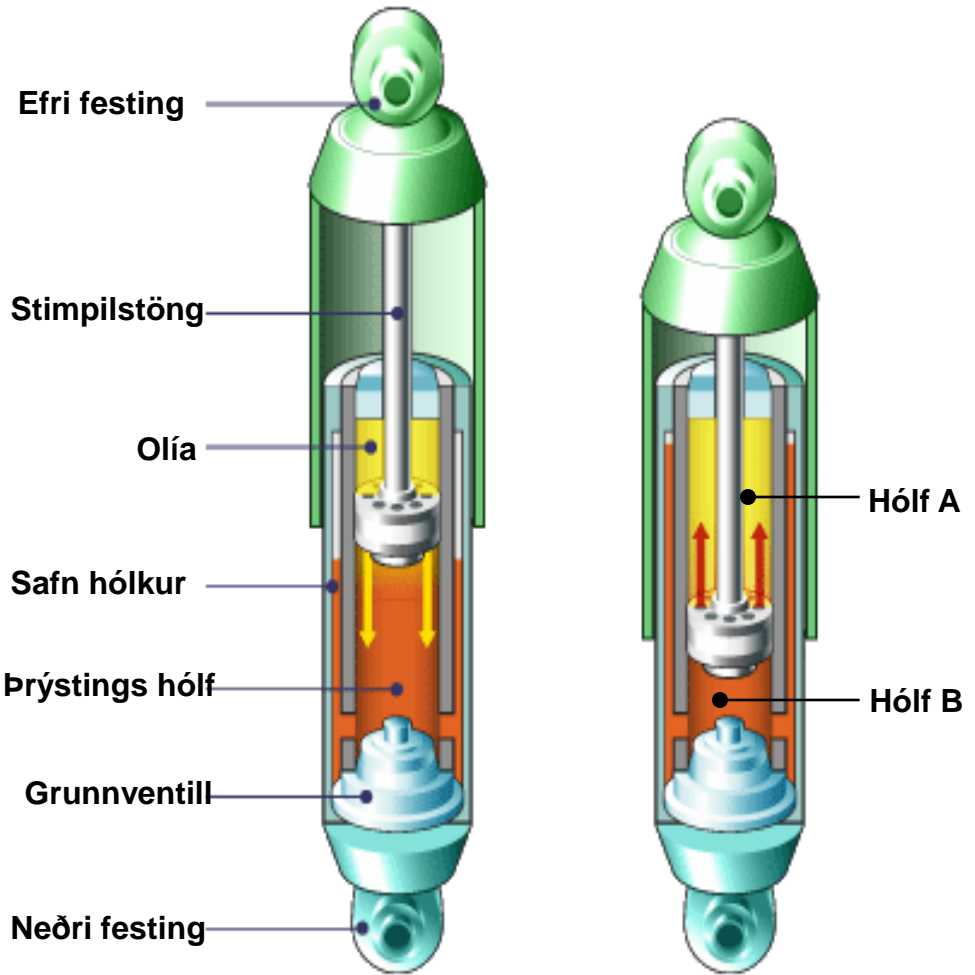

## Sundurslag

## Samanslag





# Fjöðrunarbúnaður

## Mismunandi gerðir höggdeyfa

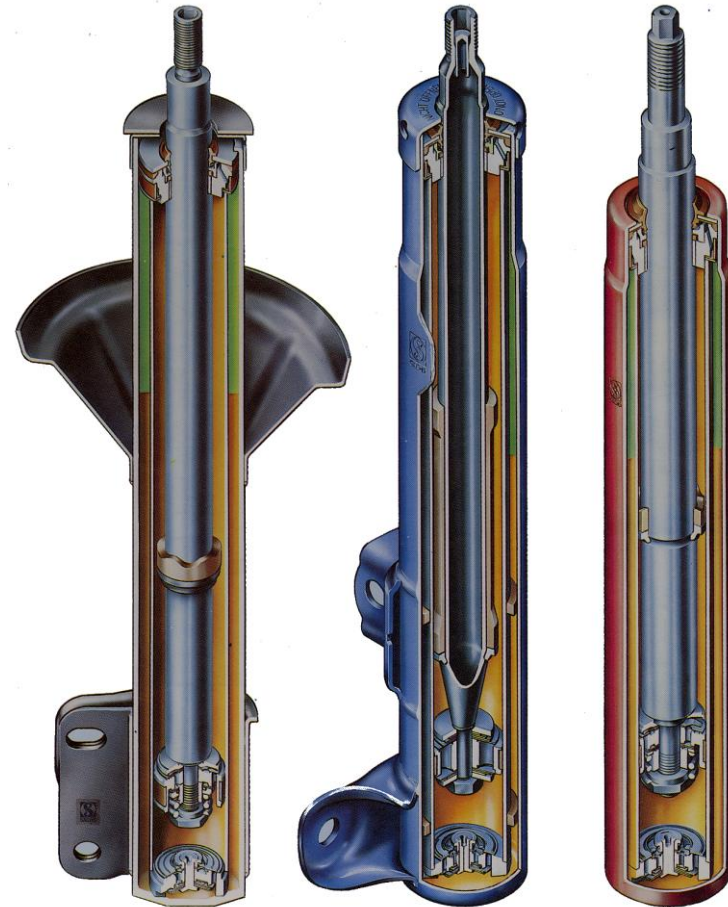
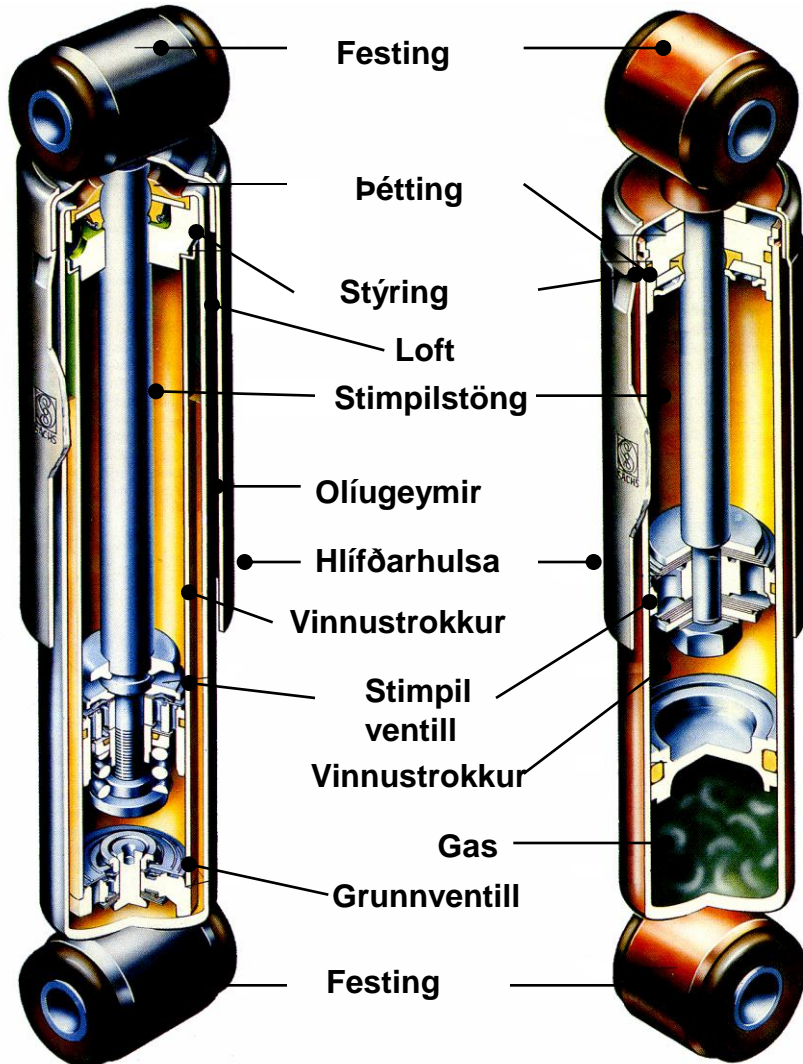

**Grunngerð með tvöfaldri túpu**

**Ein túpa með gasfyllingu**



## Sjálfstæð fjöðrun að framan



**McPherson**



**Double wishbone  
(Coil Spring type 1)**



**Double wishbone  
(Coil Spring type 2)**



**Multi-link**

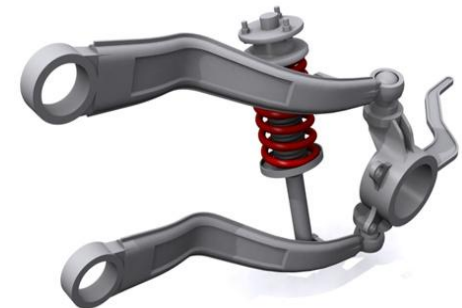
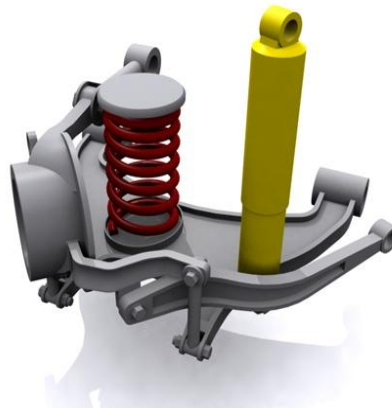

**Trailing arm**





## Ósjálfstæð fjöðrun að aftan

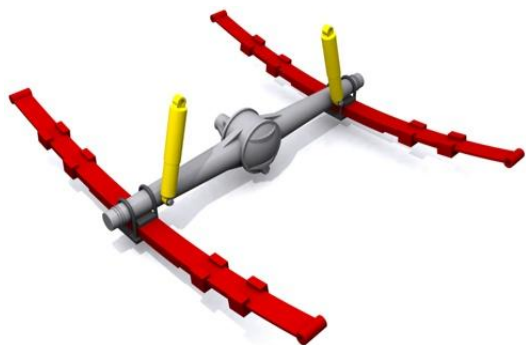

Heill ás, fjaðrir

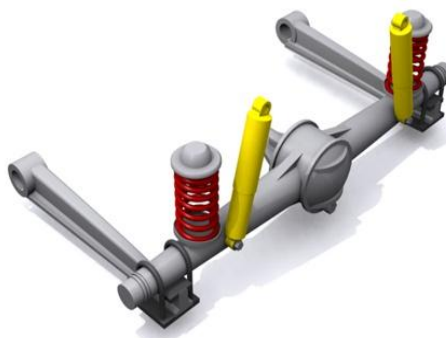

Heill ás, gormar



Þverbiti

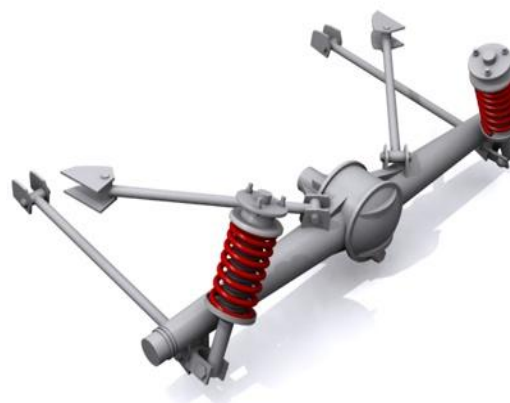
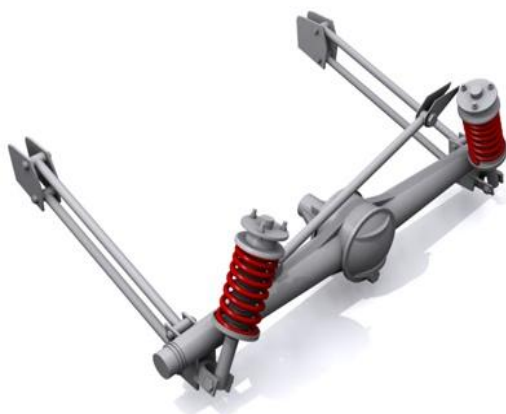

4-stanga búnaður



## Sjálfstæð fjöðrun að aftan

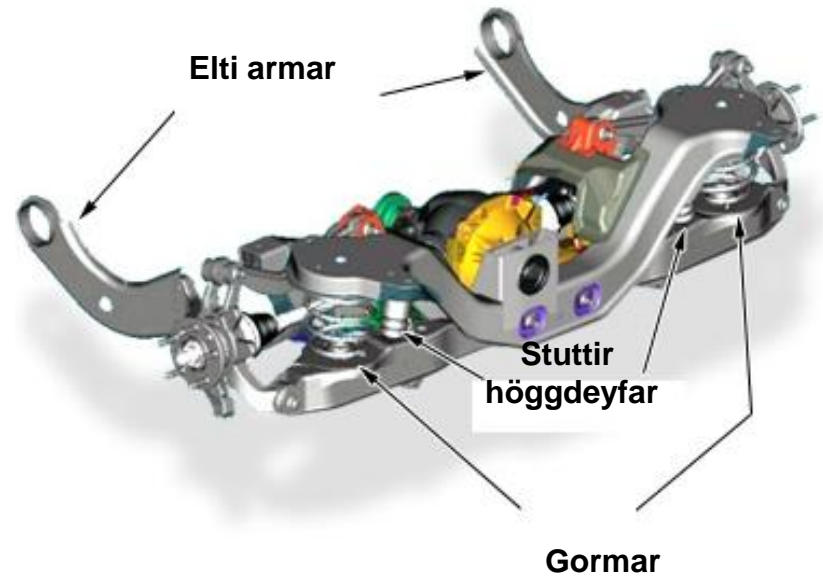
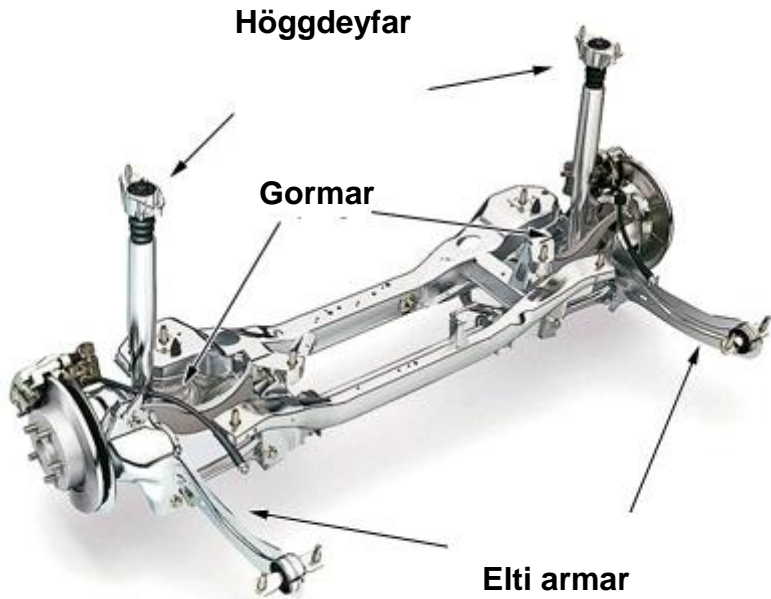



## Jafnvægistangir, gormleggjar styrking og fóðringar

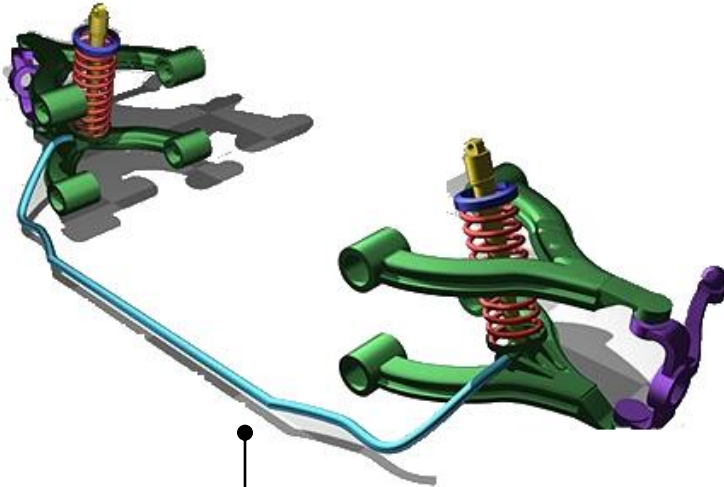

Jafnvægisstöng

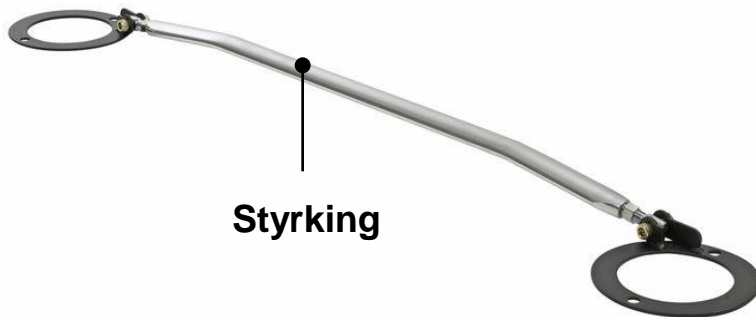

Styrking





## Bilanagreining og þjónusta



Skemmd pakkdós



Röng hersla



Uppslitin gúmmifóðring

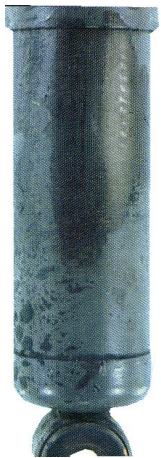
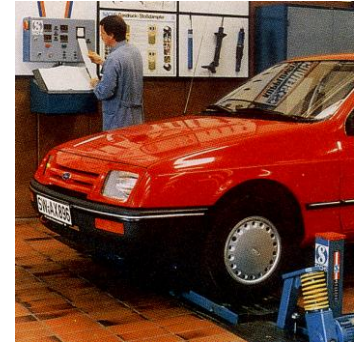

Nudd eftir varnarhlíf



Fastur höggdeyfir



Sprungu í festingu



Brotin festing



Höggdeyfar kannaðir





## Hjólastilling

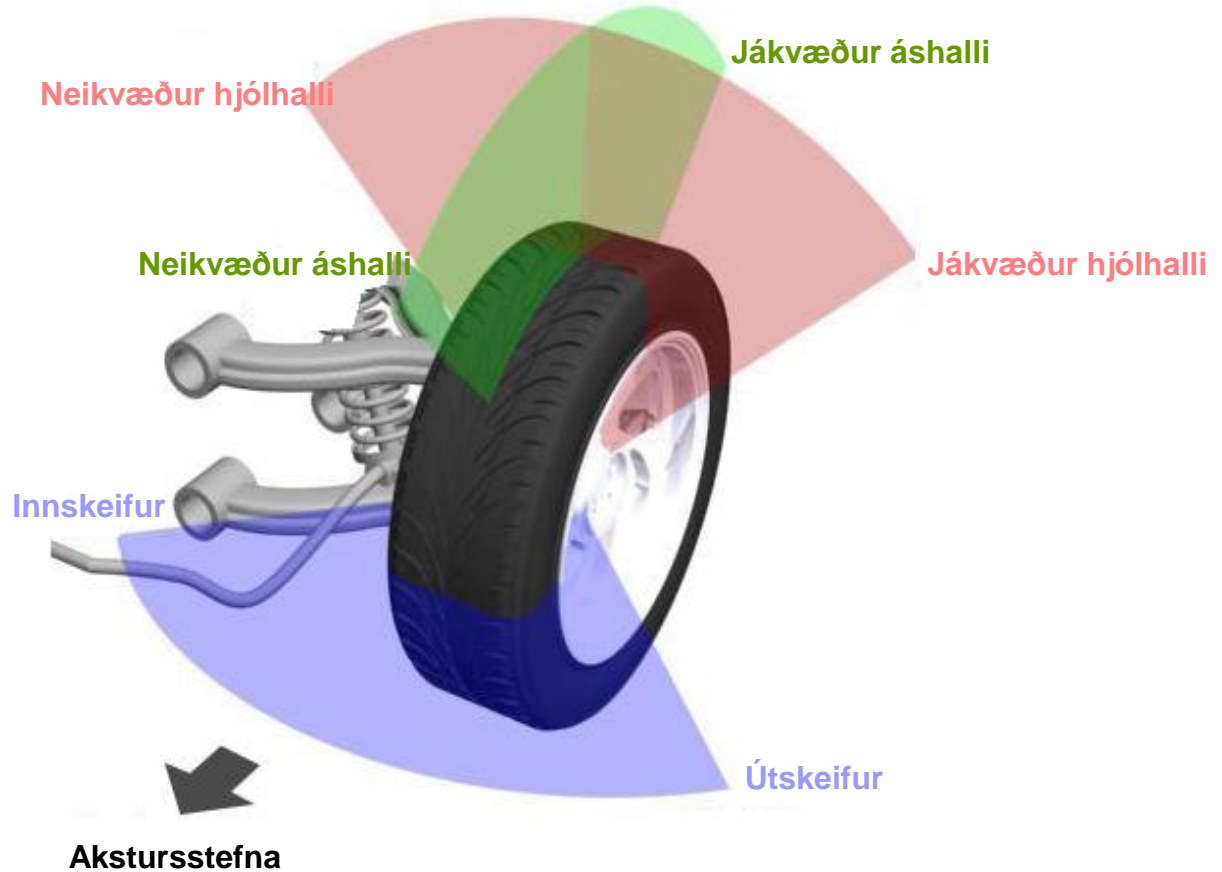
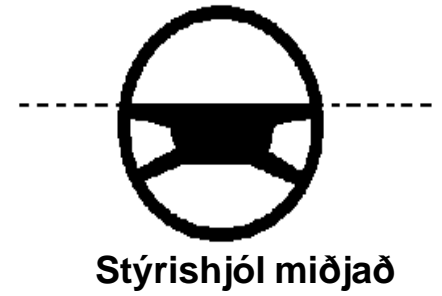
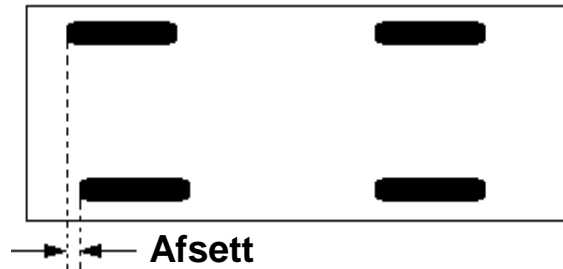
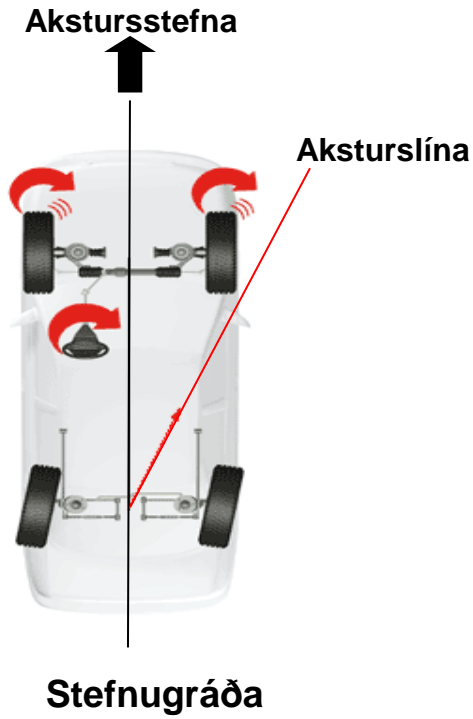



## Hjólhalli “camber” og áshalli “caster”

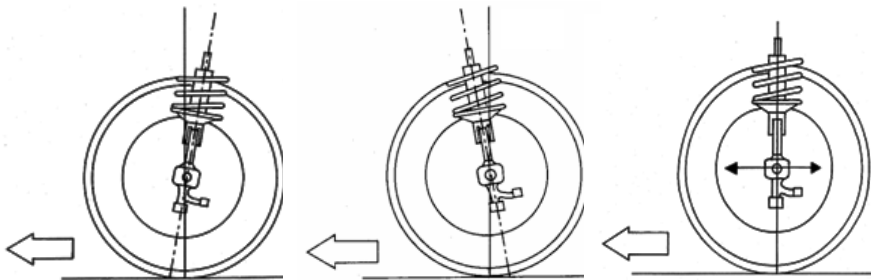
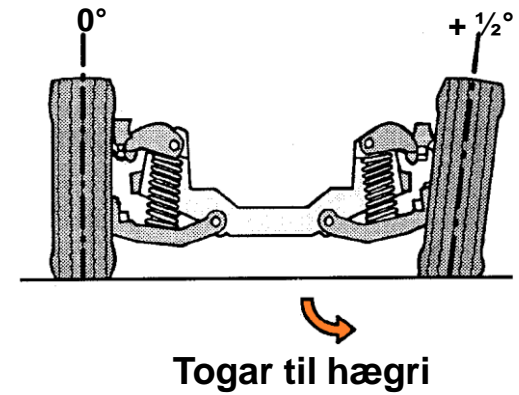
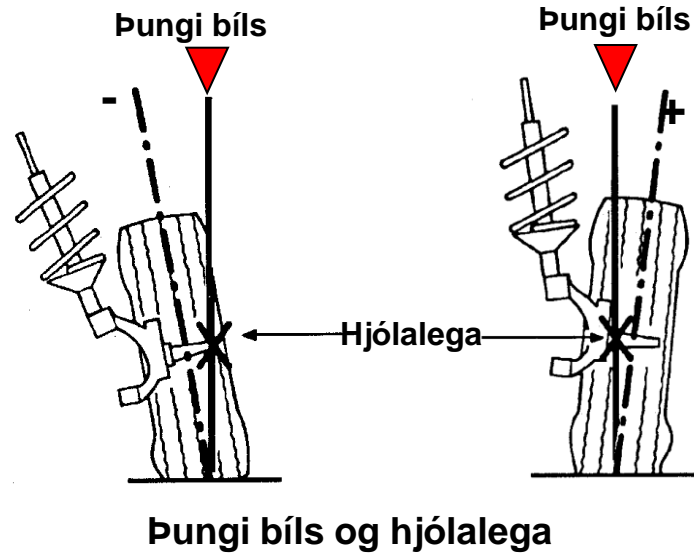
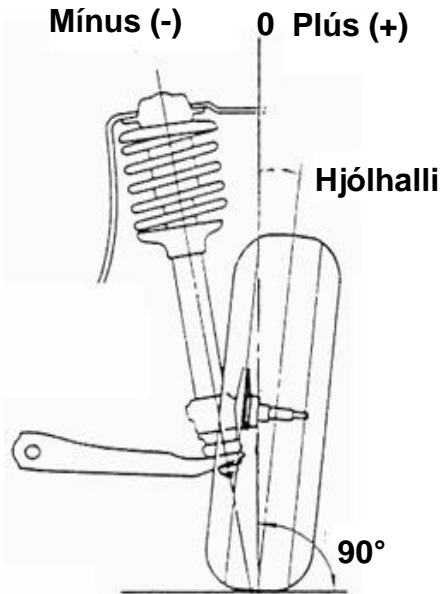

Jákvæður áshalli Neikvæður áshalli 0 áshalli





## Innhalli stýrisvalar, samreiknuð horn, afstæður stýrisvalarhalli og veghæð

Halli stýrisvalar

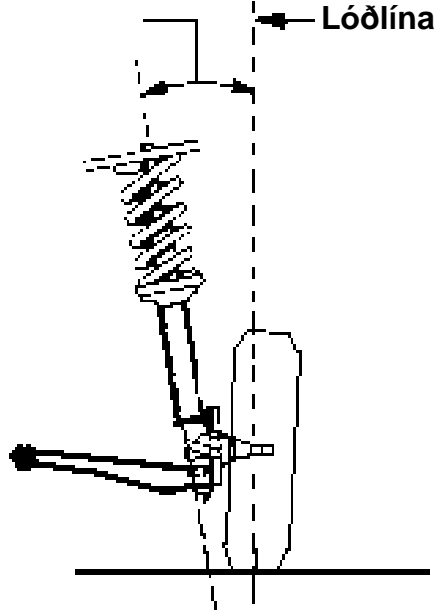

Samreiknuð horn

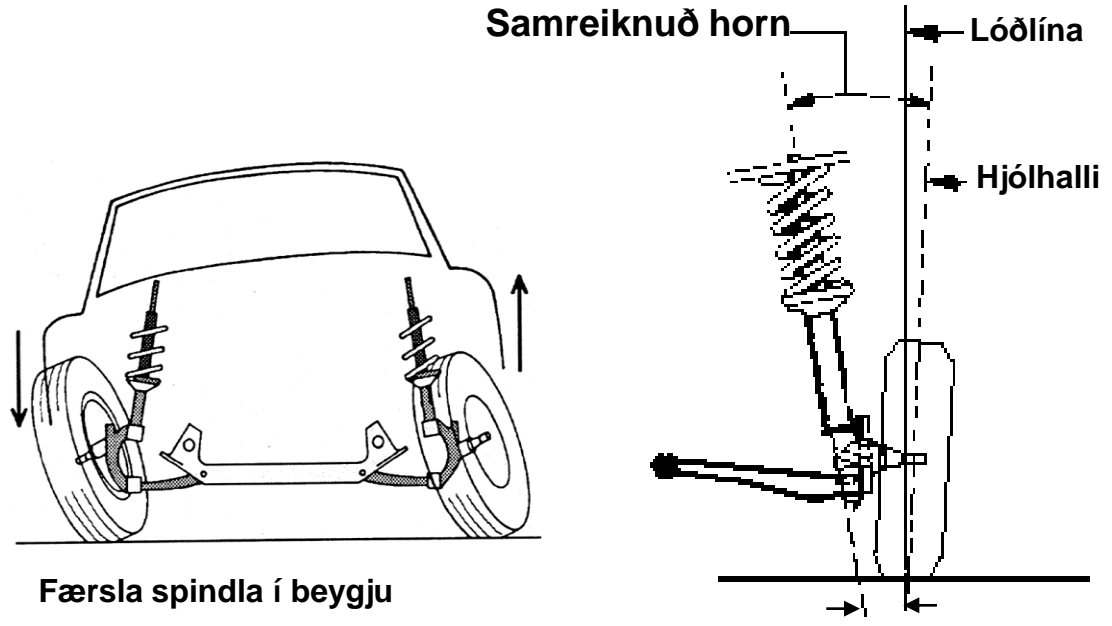

“Scrub radius”  
Afstæður halli stýrivalar

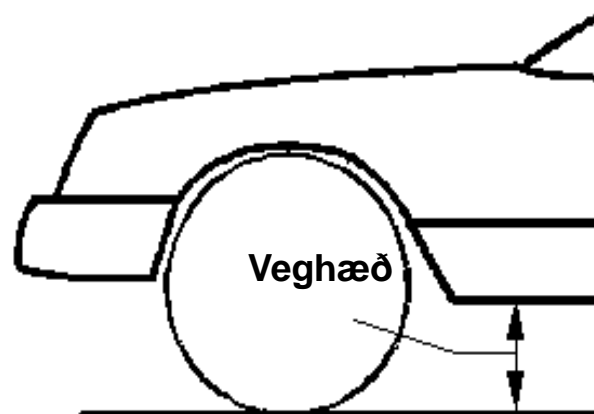



## Hjólamillibil

Innskeifur  
(Jákvæður)

Útskeifur  
(neikvæður)

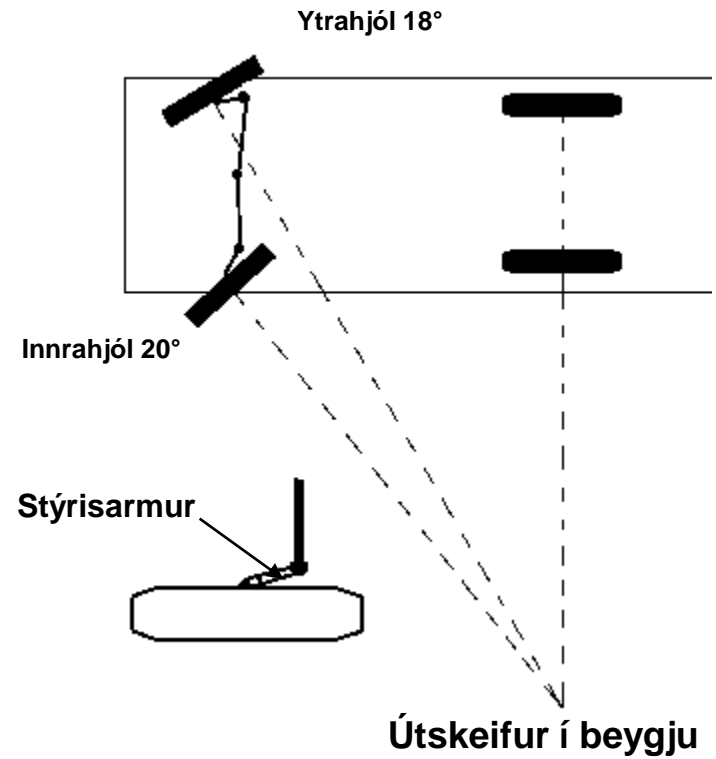
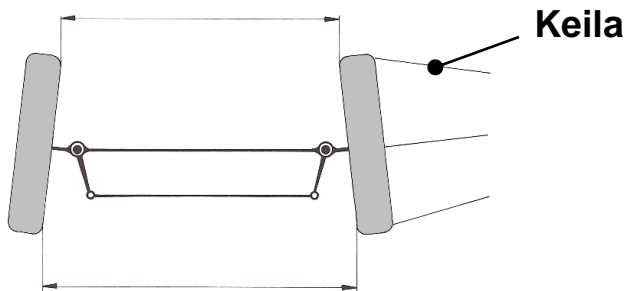
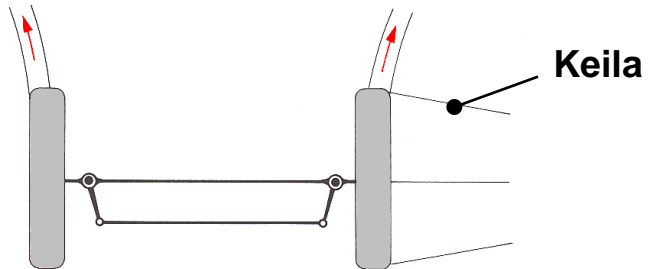
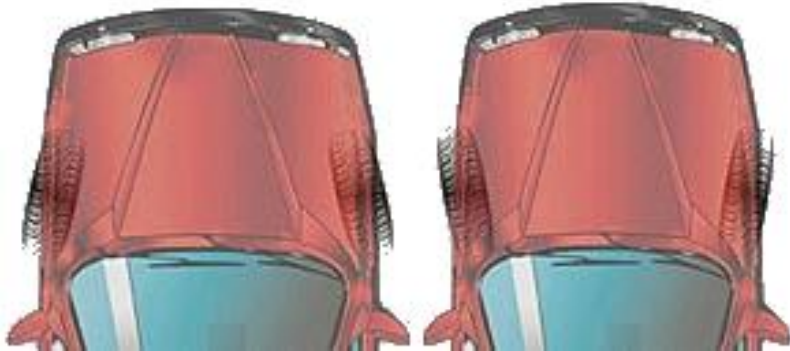



## Undirbúningur, mæling millibils og hjólhalla

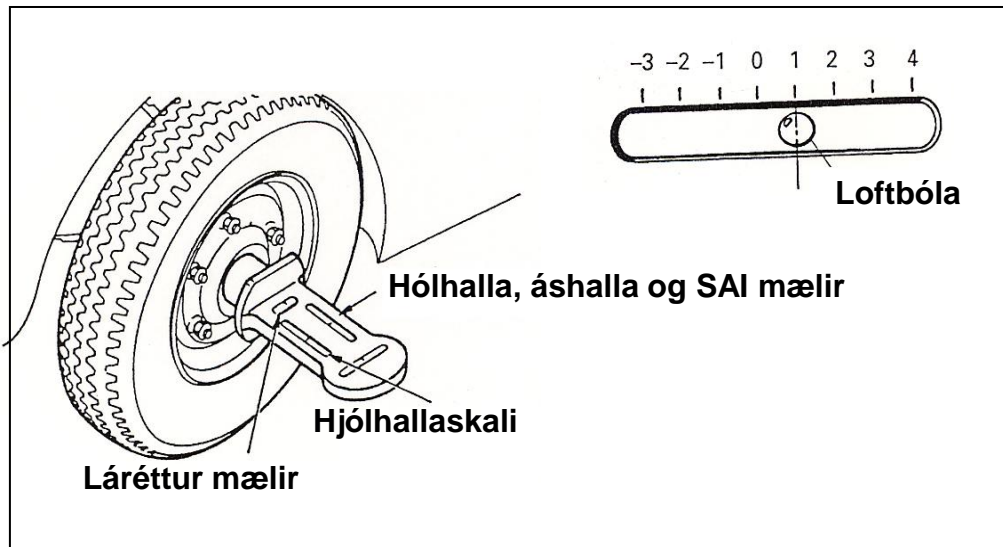
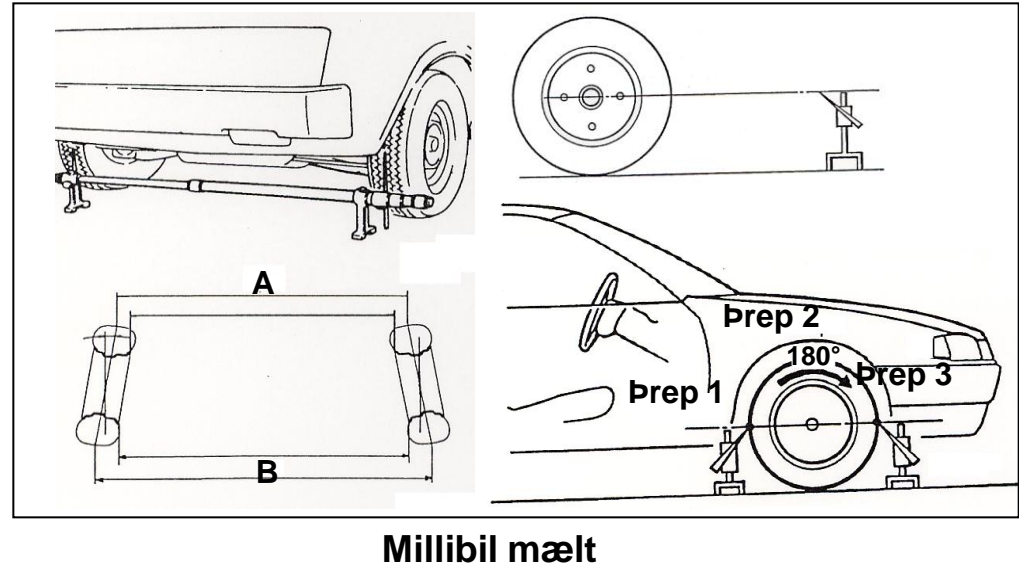
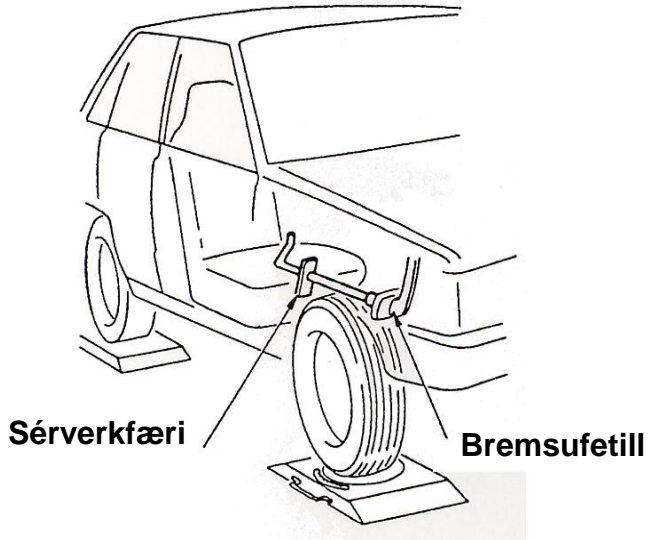

Hjólhalli mældur

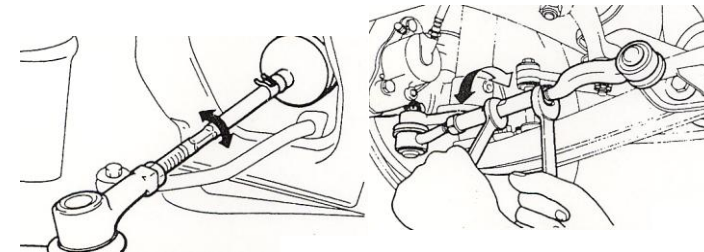

Millibil still



## Áshalli og SAI mældir

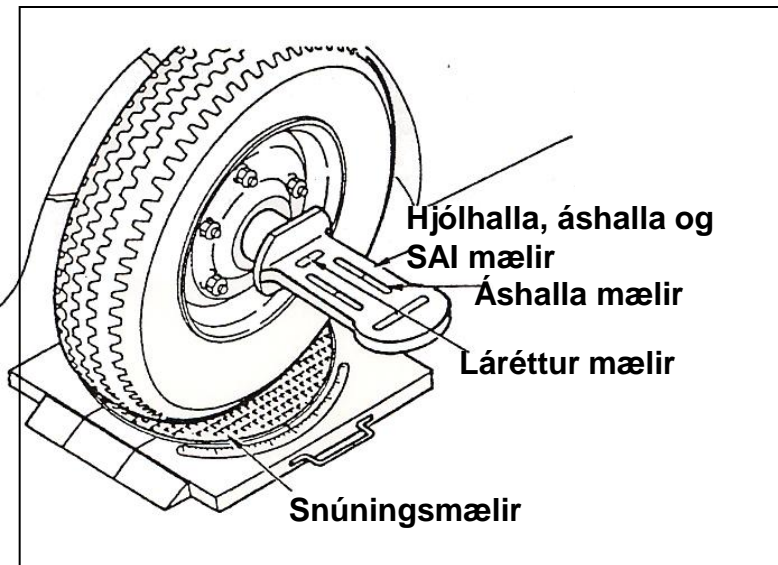

Áshalli mældur

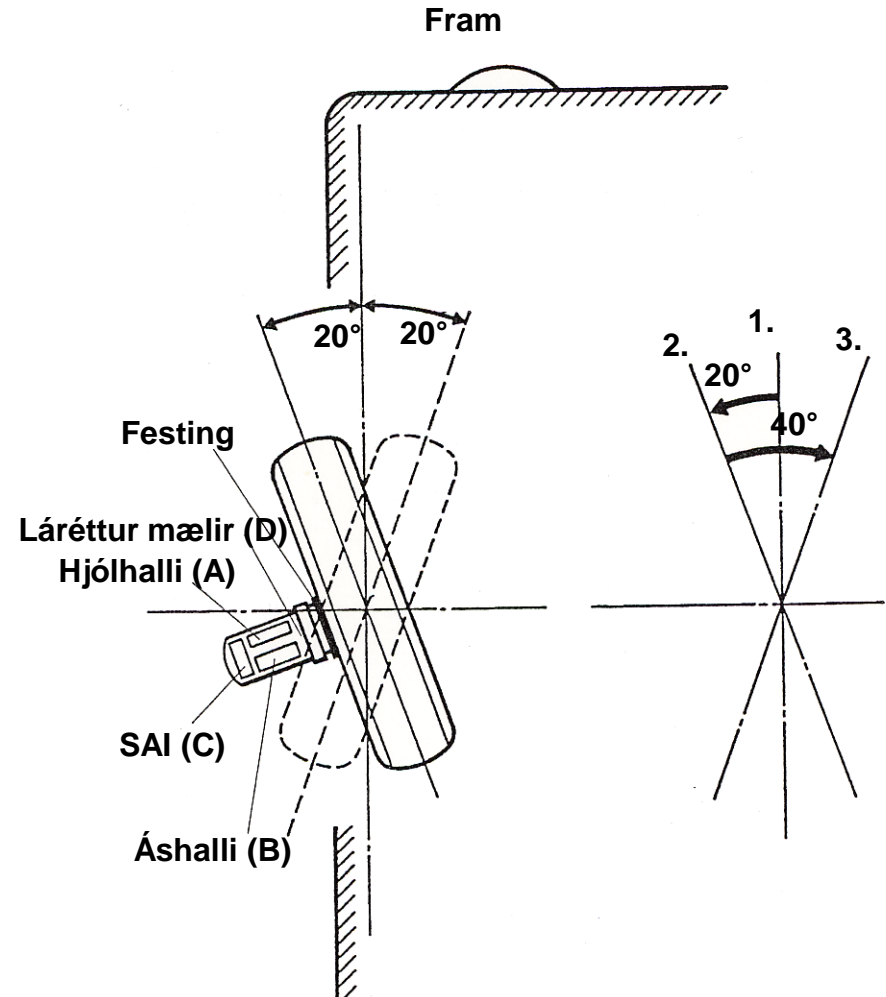



## Hjólbarðar

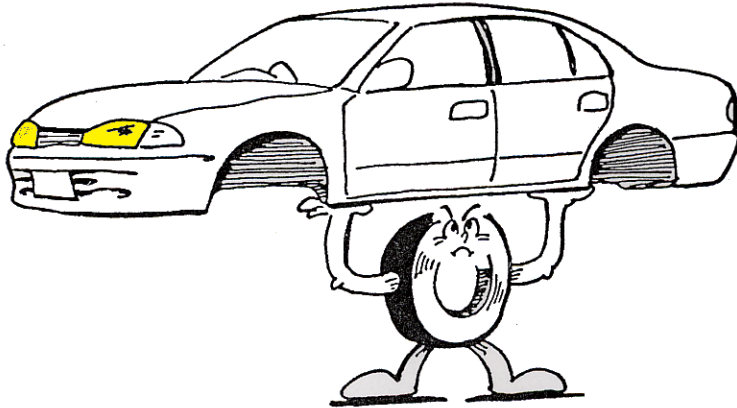

Bera þunga bílsins



Hlaupið með því að spyrna í jörðina

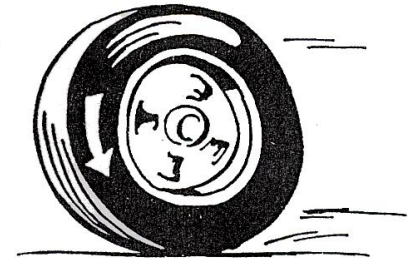

Mynda dráttar- og hemlunarkraft

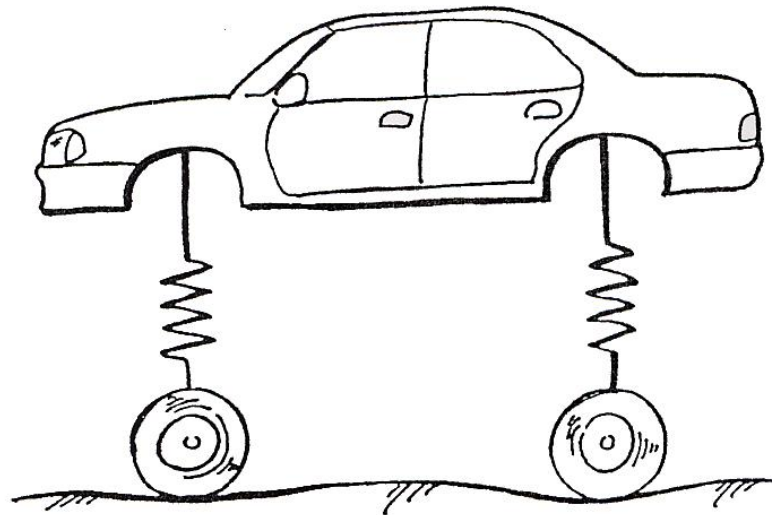

Dempa hluta af höggunum frá veginum



## Hjólbarðar, gerðir og uppbygging

Performance / summer

All weather

Mud / Snow

All terrain

Mud



Tire Types

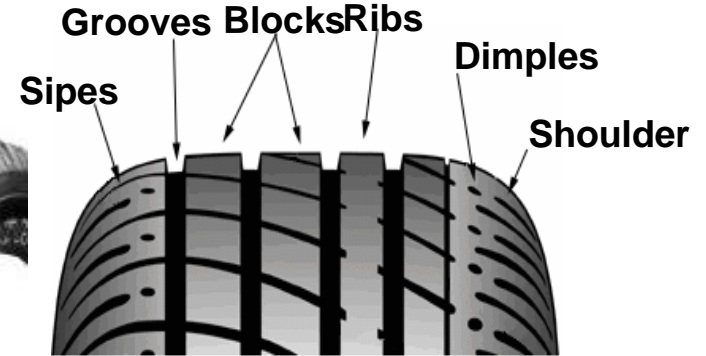

Tire tread

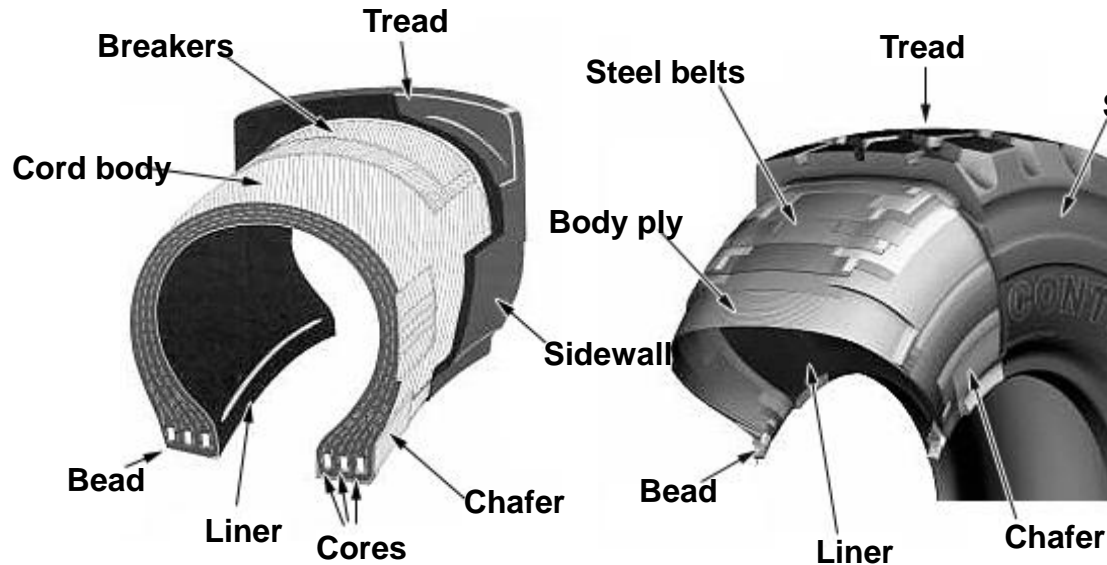

Cross-Ply Construction

Radial Construction



Symmetrical

Asymmetrical

Unidirectional





## Hjólbarðar, merkingar

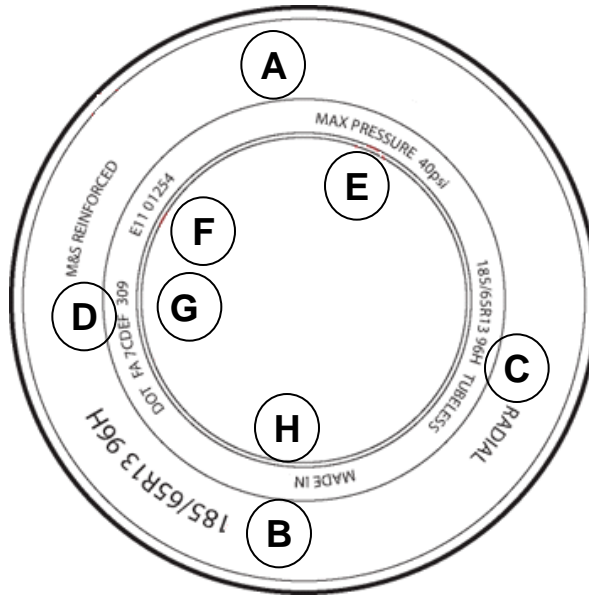

Mynd 1

# 185 / 65 R13 96H

Breidd barða

Hæðarhlutfall

Byggingarlag

Hámarkshraði

Hleðsluþol

Felgustærð

E (11) 01254

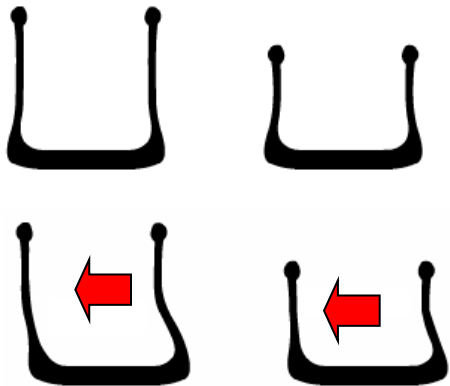

Hliðaráttak

Hæðarhlutfall

Speed symbol	Max. Car speed capability	
	Km/h	Mph
L	120	75
M	130	81
N	140	87
P	150	95
Q	160	100
R	170	105
S	180	113
T	190	118
U	200	125
H	210	130
V	240	150
W	270	168
Z	2	

Load index	Weight (kg)
50	190
52	200
54	212
70	335
72	355
74	375
90	600
91	615
92	630
93	650
94	670
95	690



## Felgur og merkingar þeirra

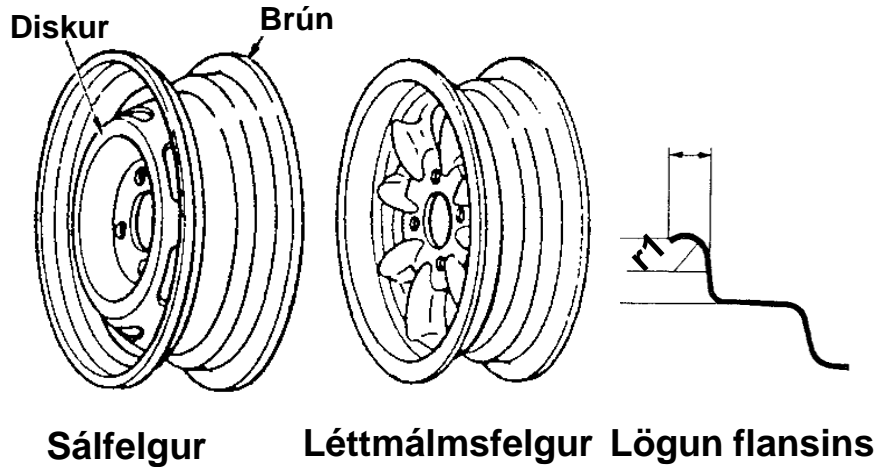

**5 1/2 - JJx13 4 114.3 15**

- Breidd felgu
- Flans merking
- Þvermál „tommur“
- Fjöldi festibolta
- Fjarlægð milli bolta
- Afstæð

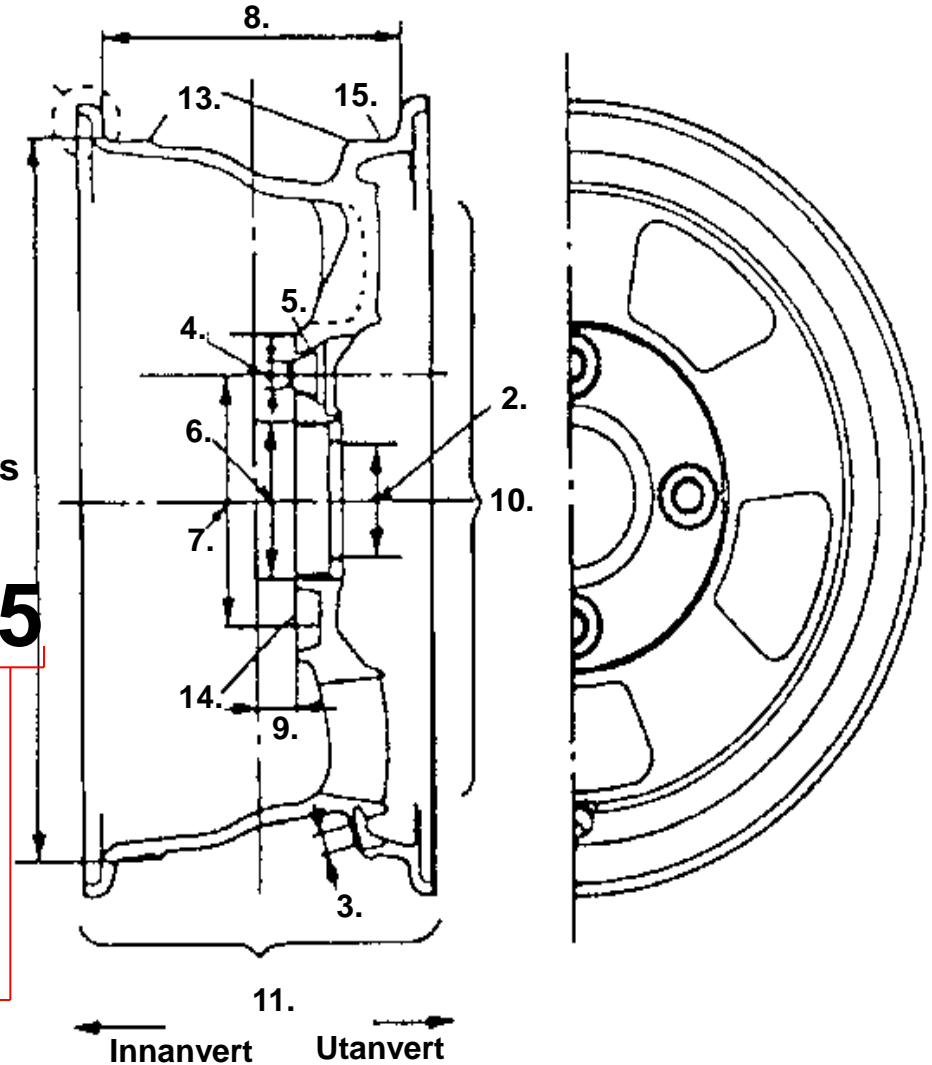



## Athugun á hjólum

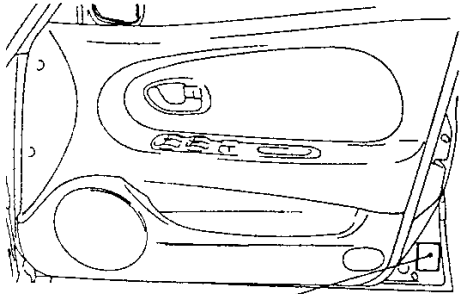

Merkingar fyrir þrýsting

Loftþrýstingur athugaður

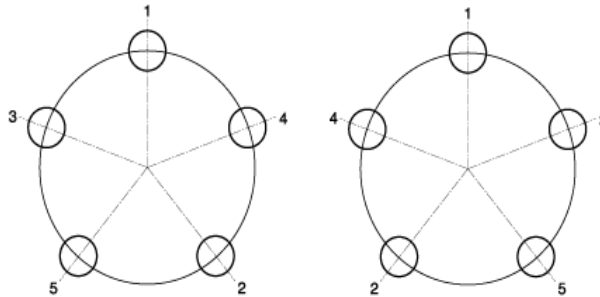

Aðferðir við herslu

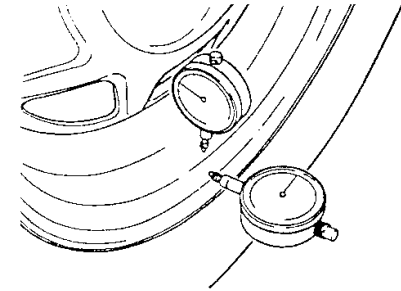

Kast á felgu kannað

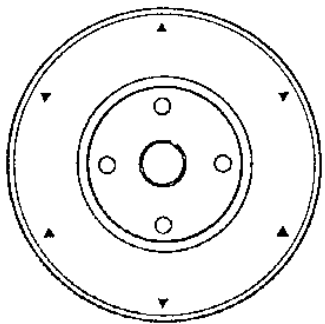

Slitmark

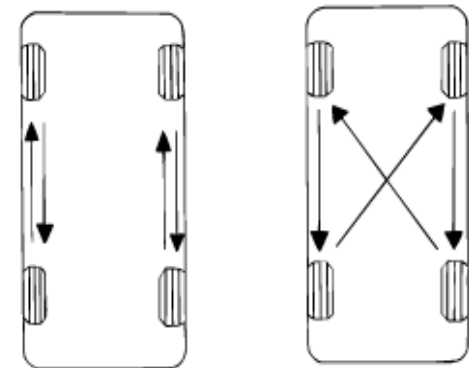
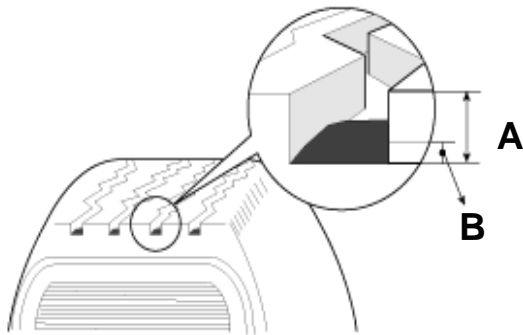

Tilfærsla hjólbarða



## Hjólbarðaskipti og jafnvægisstilling

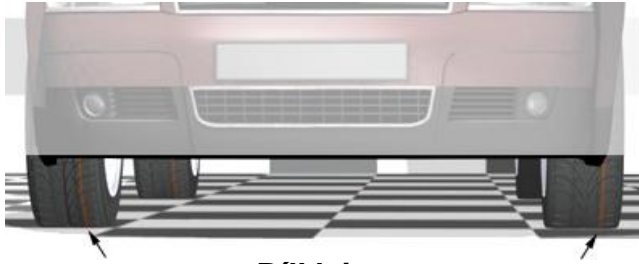

Bíll leitar



Bíll ekur beint

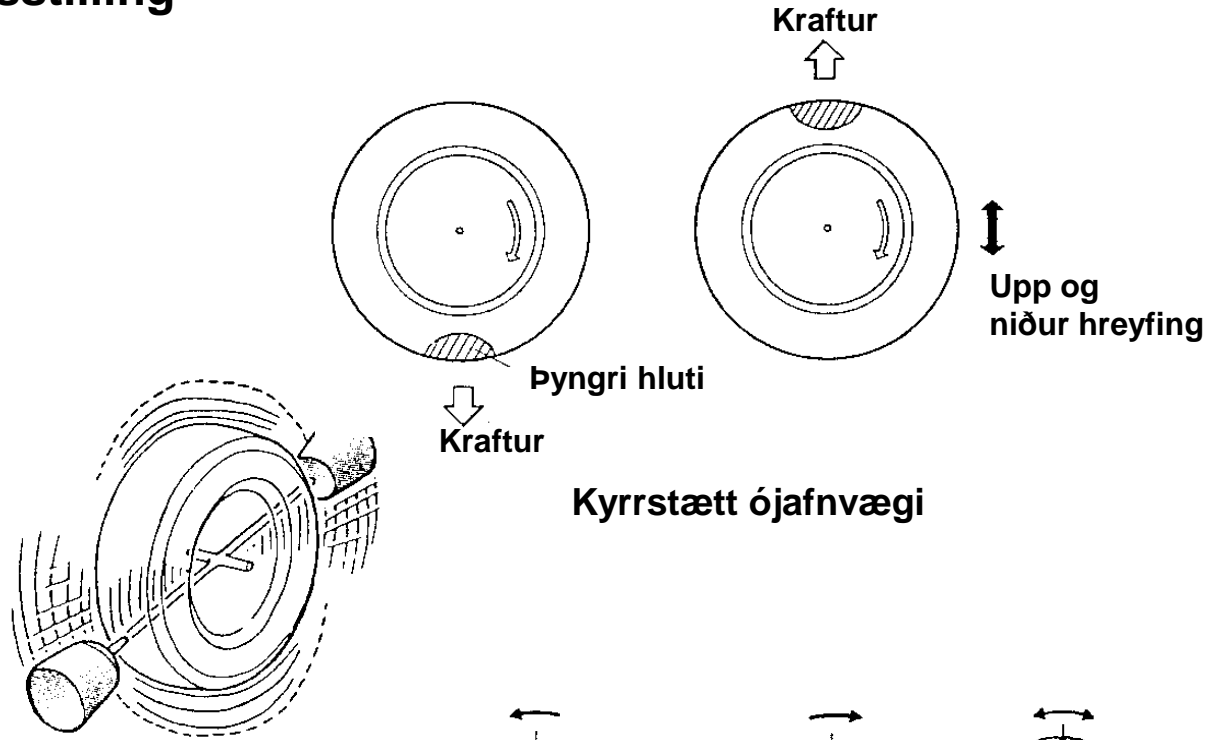

Kyrrstætt ójafnvægi

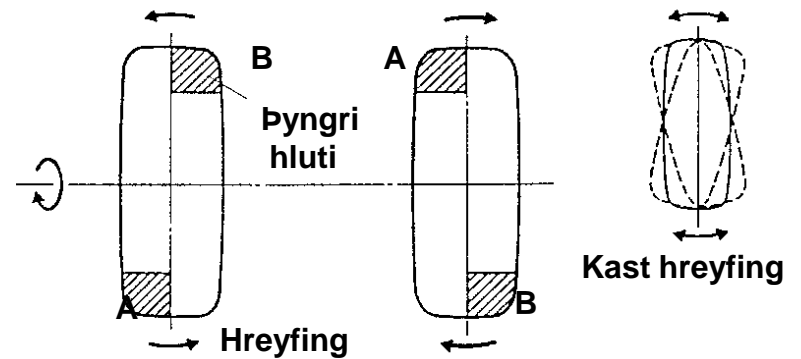

Hreyfanlegt ójafnvægi

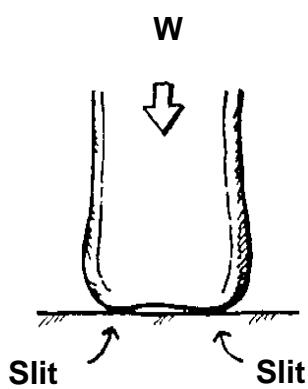
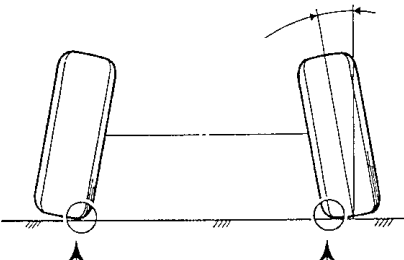
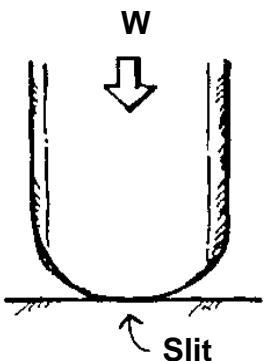
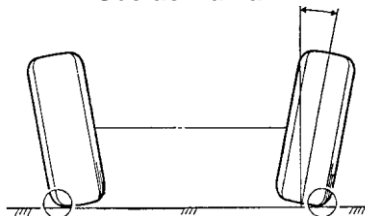

## Hjólbarðaslit og hugsanlegar orsakir

Slitmyndur	Hugsanleg orsök	Slitmyndur	Hugsanleg orsök
Báðar brúnir slitnar	<ul style="list-style-type: none"><li>Of lár loftþrýstingur</li></ul> 	Innri brún slitin	<ul style="list-style-type: none"><li>Neikvæður hjólhalli</li></ul> Séð að framan  Innhalli hjólsins veldur slit á innri brún
Miðja slitin	<ul style="list-style-type: none"><li>Of hár loftþrýstingur</li></ul> 	Ytribrún slitin	<ul style="list-style-type: none"><li>Of mikill hjólhalli</li></ul> Séð að framan  Úthalli hjólsins veldur slit á ytri brún

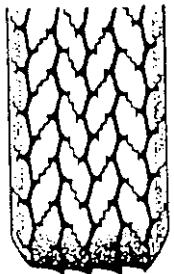
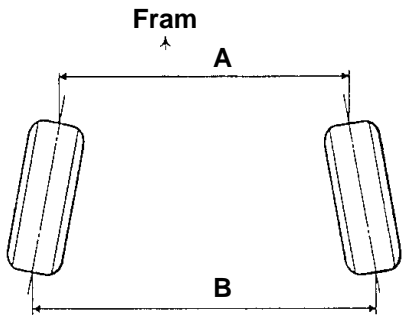
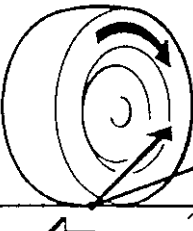
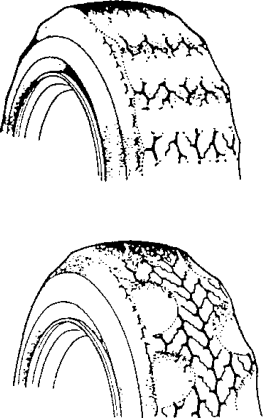
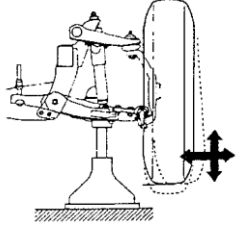
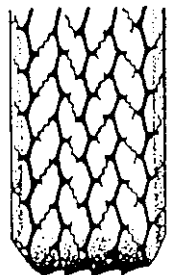

Slitmynstur	Hugsanleg orsök	Slitmynstur	Hugsanleg orsök
<p>Bíll innskeifur, slit</p>  <p>Innrihlíð</p> <p>→ Akið álag á snertiflöt hjólbarðans</p>	<ul style="list-style-type: none"><li>Of innskeifur (B-A&gt;en uppgefið gildi)</li></ul>   <p>Stefna bíls</p> <p>Stefna hjólbarðs</p> <p>a</p> <p>Skautar til hliðar</p>	<p>Hlykkjótt eða bletta slit</p> 	<ul style="list-style-type: none"><li>Hjól ekki í jafnvægi</li><li>Vanstilling á hjóli</li><li>Los á legu</li><li>Hlaup í hjólabúnaði</li></ul> 
<p>Bíll útskeifur, slit</p>  <p>Innrihlíð</p> <p>← Aukið álag á snertiflöt hjólbarðans</p>	<p>Þar sem stefna bílsins og hjólsins er ekki sú sama, skautar dekkið á veginum og heflast upp.</p>		