

Guðmundur Einarsson

Hvað er mikilvægast

- Hreinlæti
- Reglusemi
- Þekking

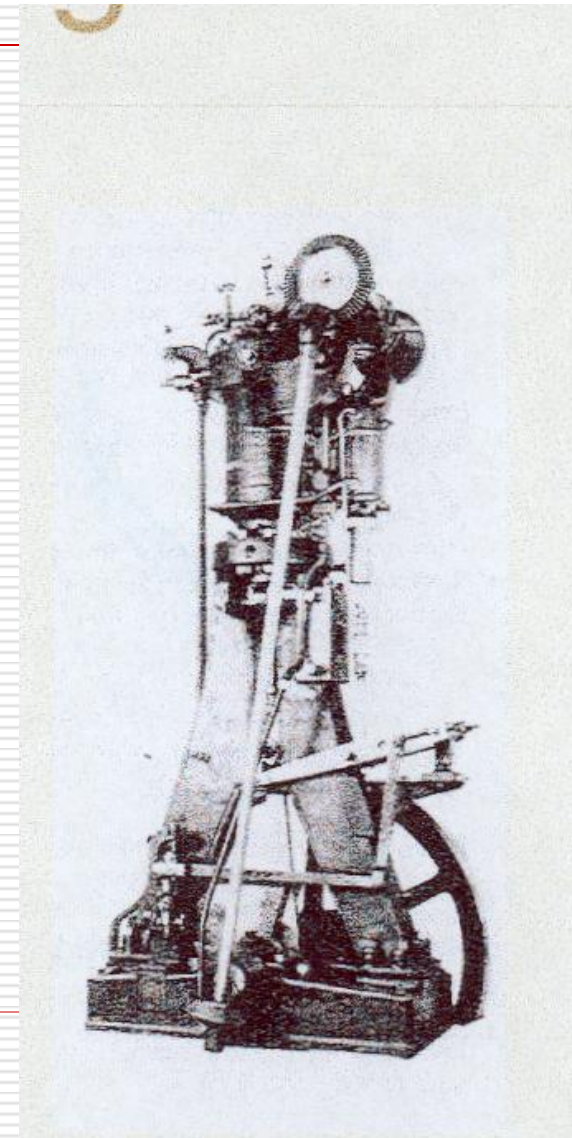

RTA-series
low-speed
engines
1480 – 48600 kW

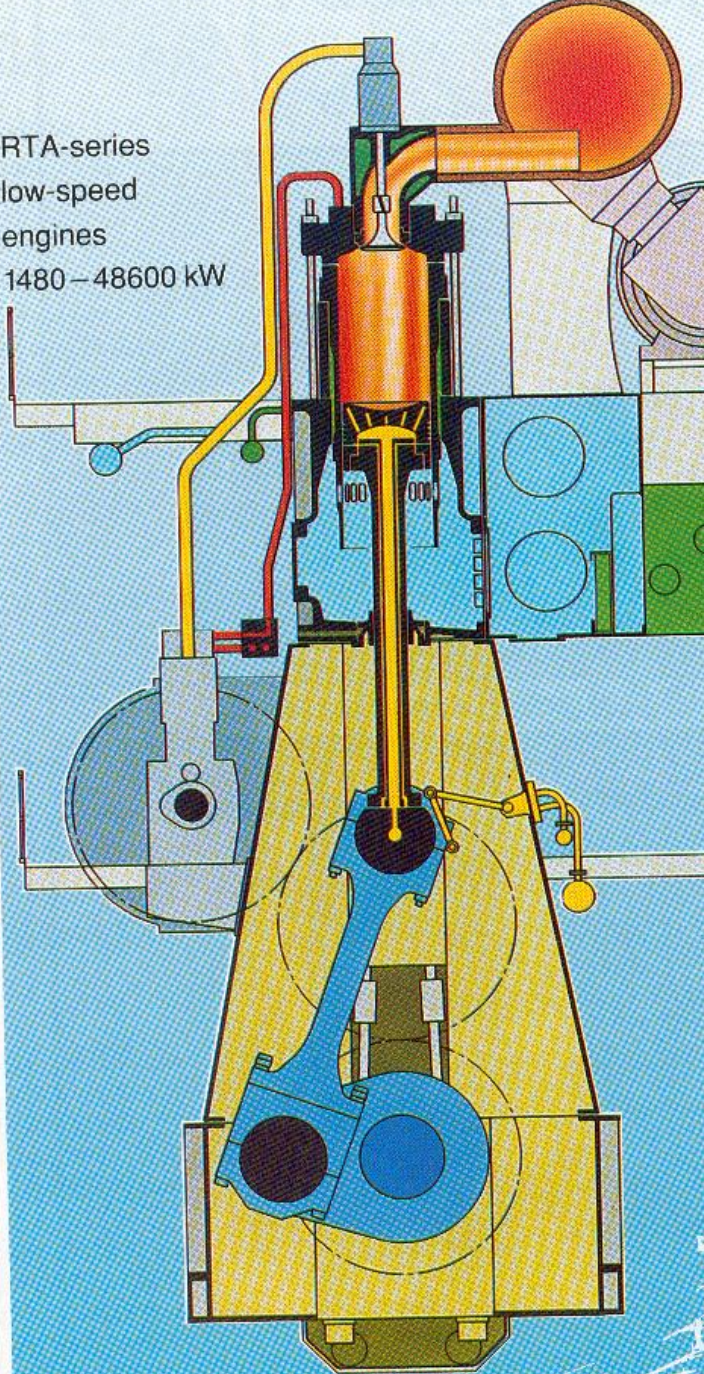

Flokkun véla

Ottóvélar

Díselvélar

Semidíselvélar (Glóðarhaus)

Hvað er ein vél

Kælivatnskerfi

Smurolíukerfi

Brennsluolíukerfi

Skoloftskerfi

Gerð véla

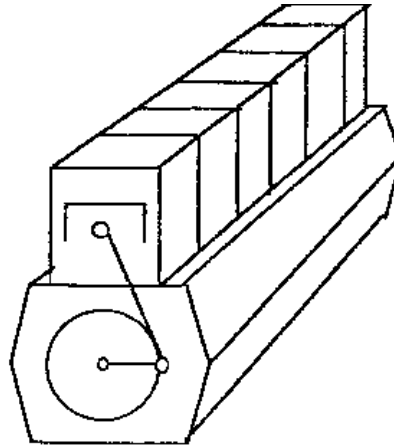

Línubýggð vél.

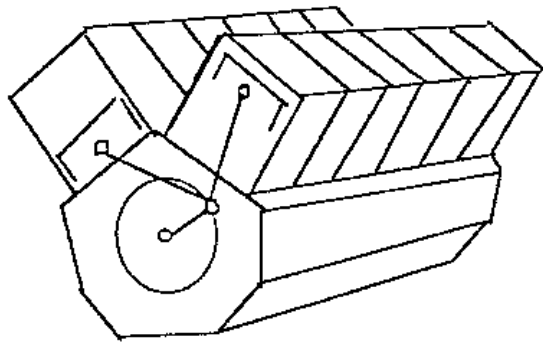

V-býggð vél

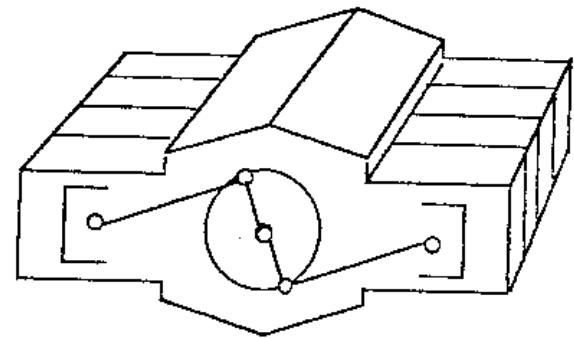

Boxervél

Krosshausvélar

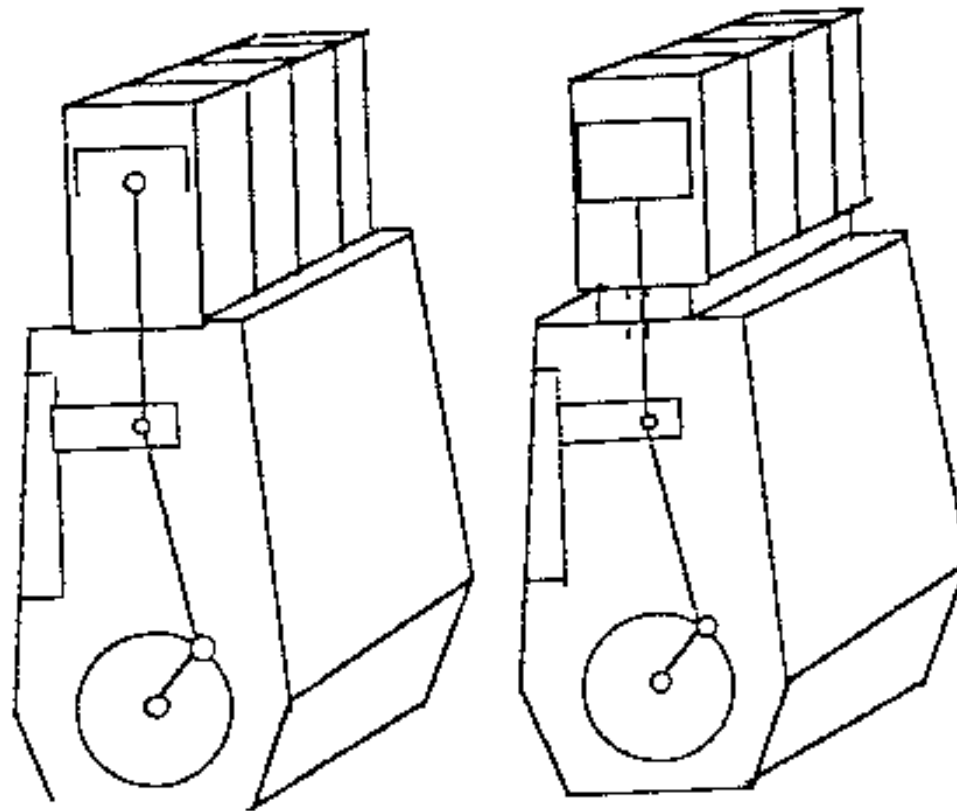

Fjórgengisvél

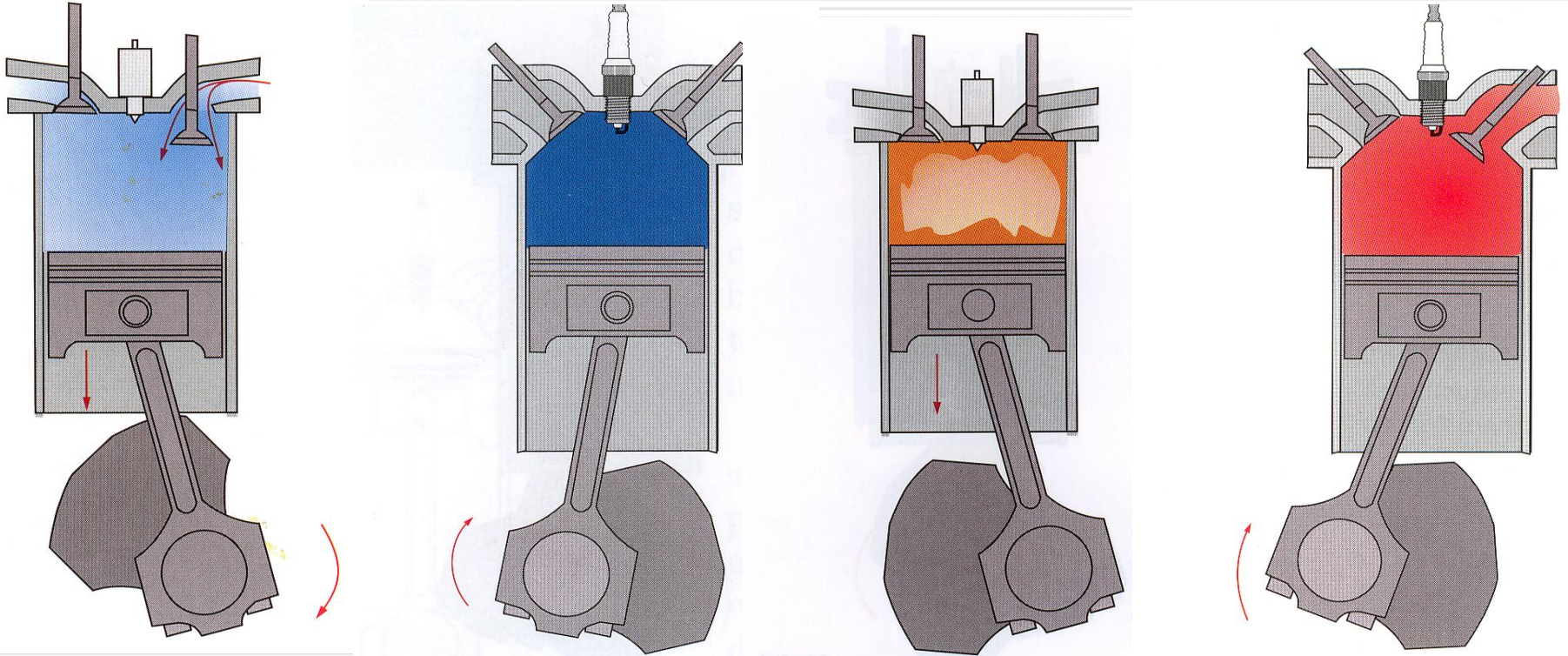

Guðmundur Einarsson

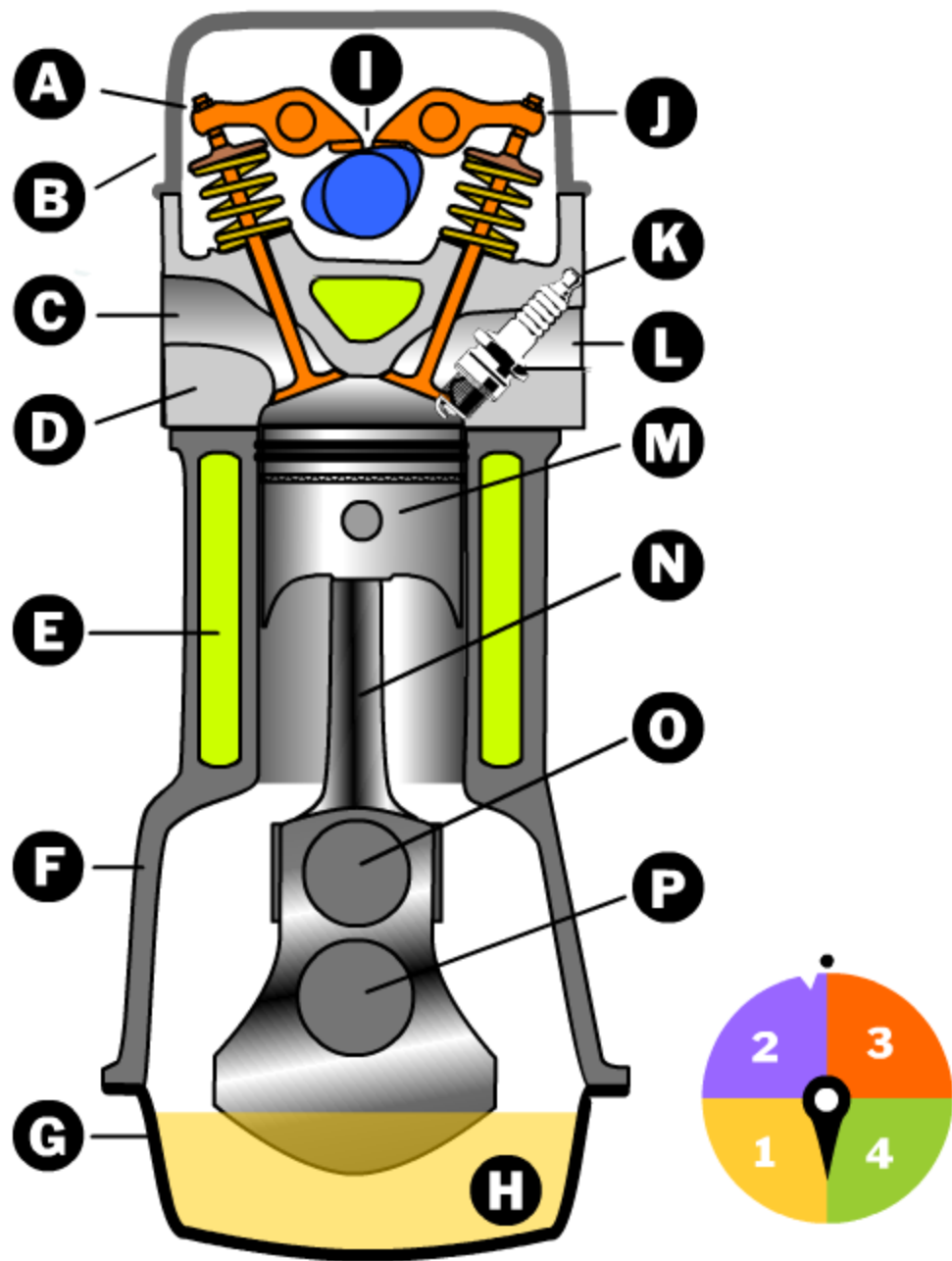

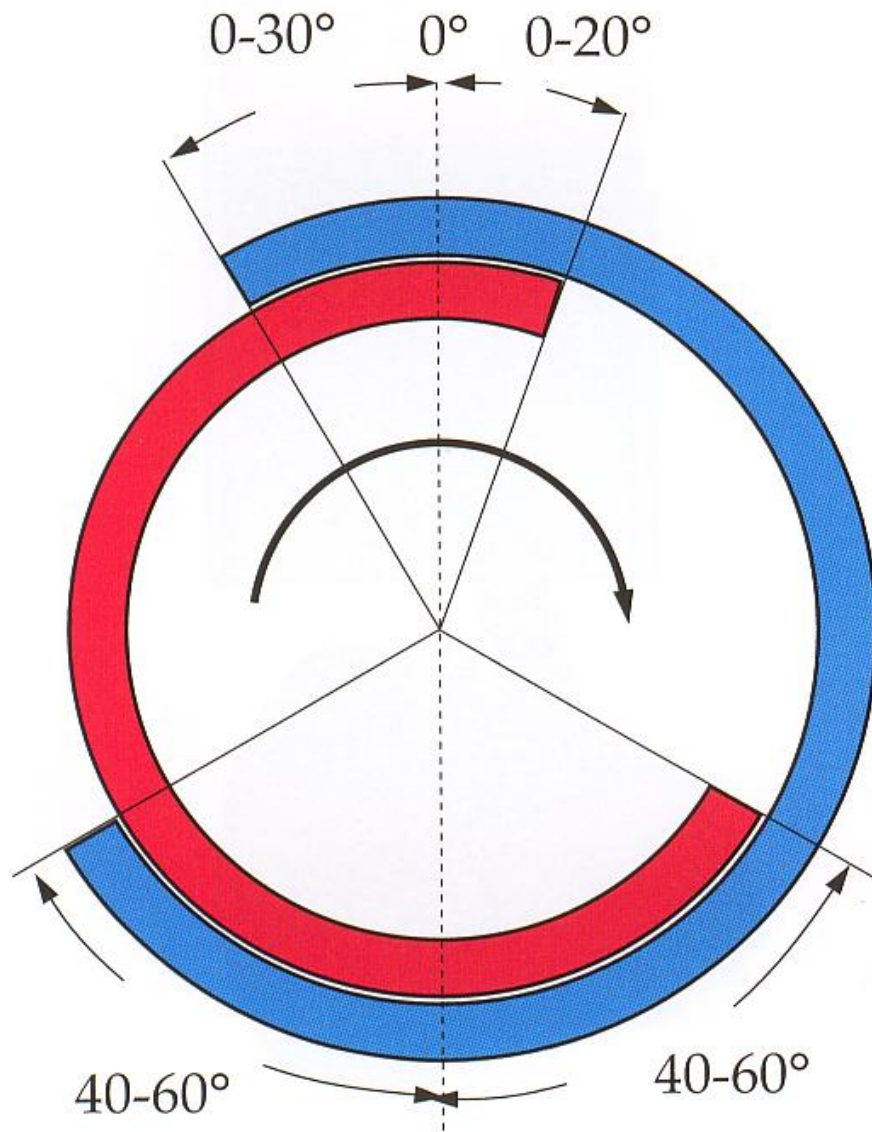

Fortsetzung

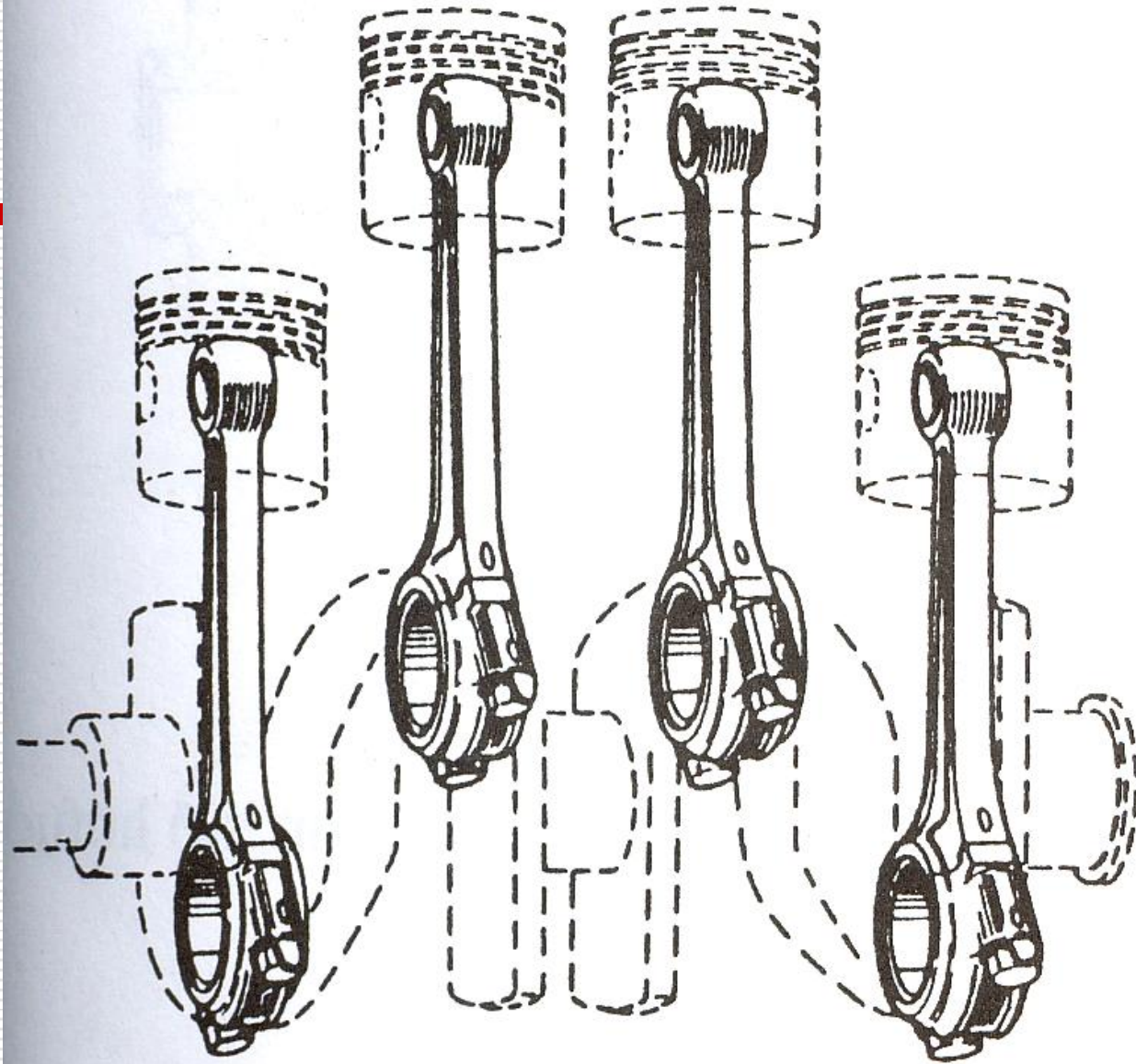

Tvígengisvél

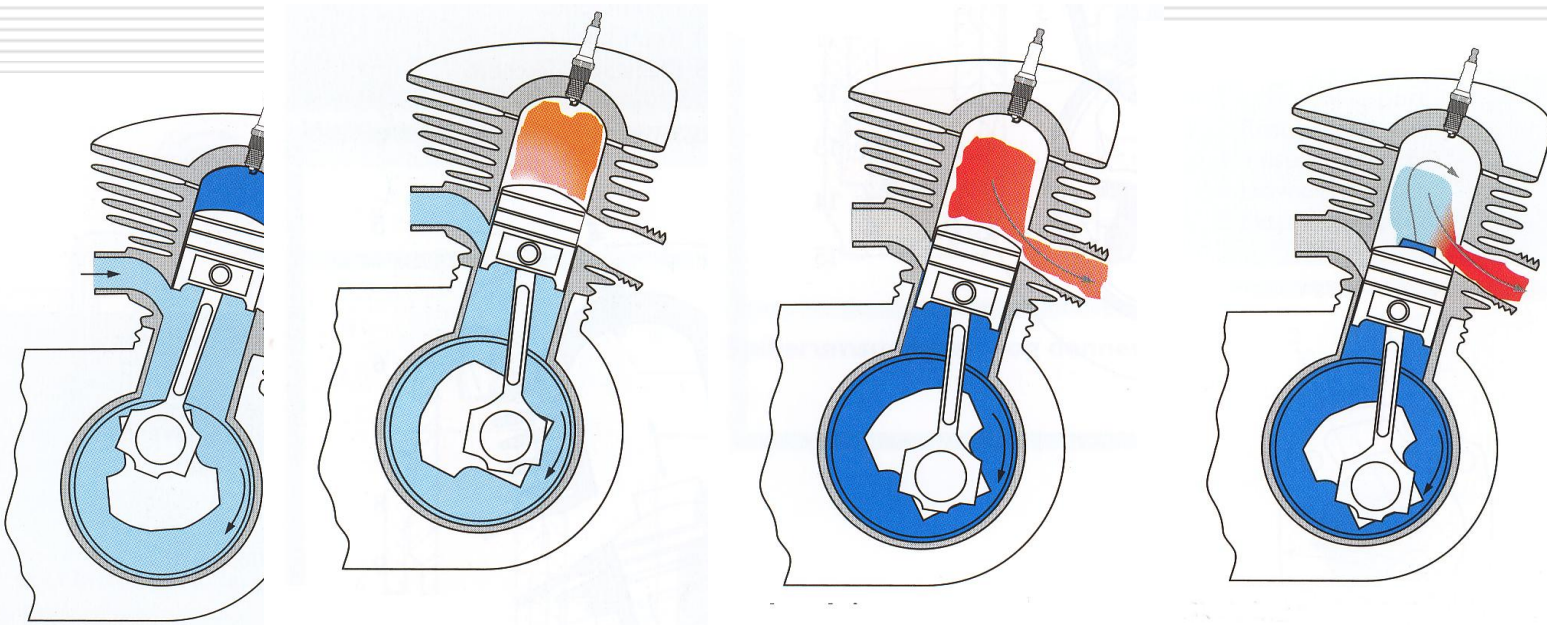

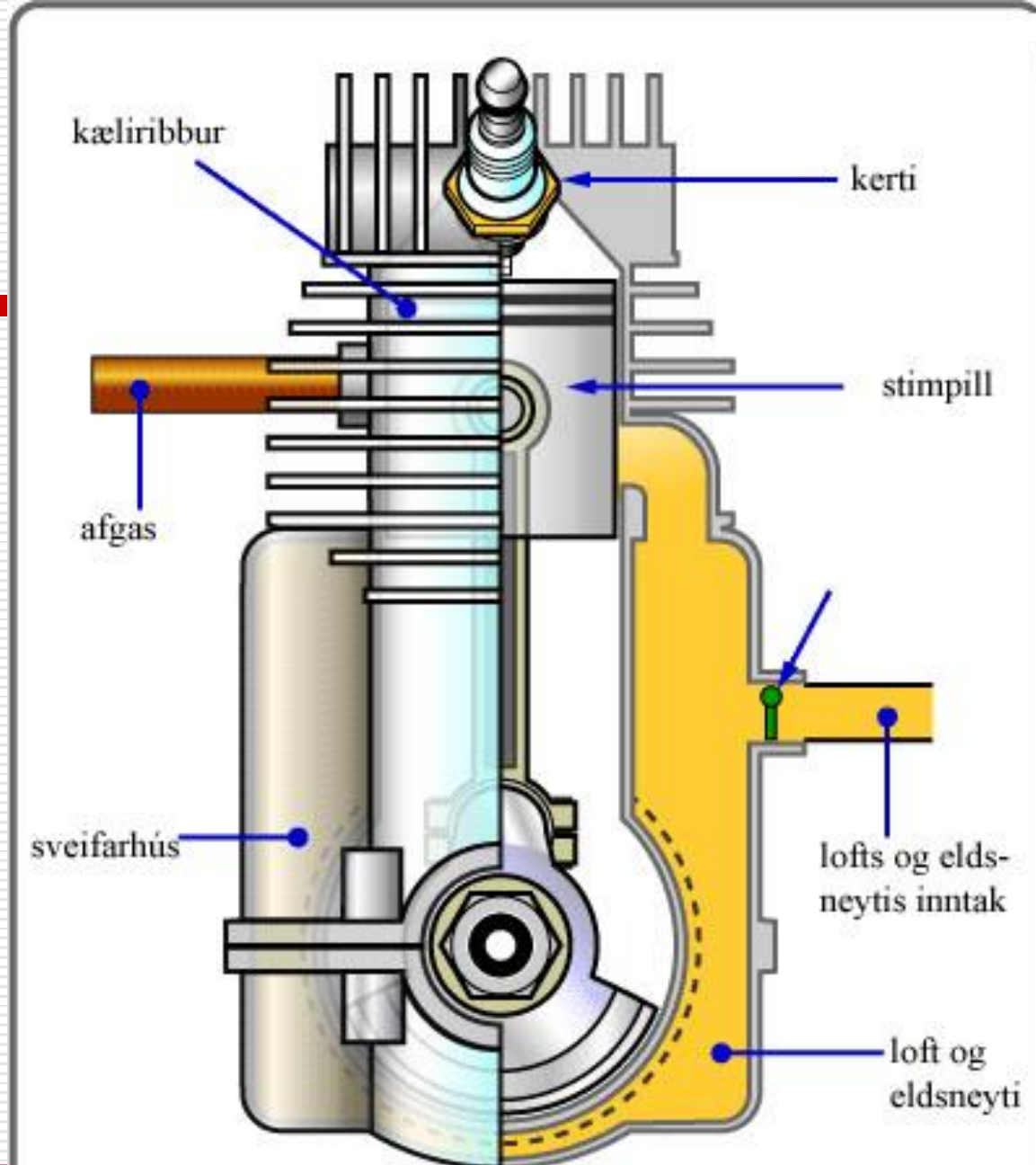

The basic components of a two-stroke engine

©2001 HowStuffWorks

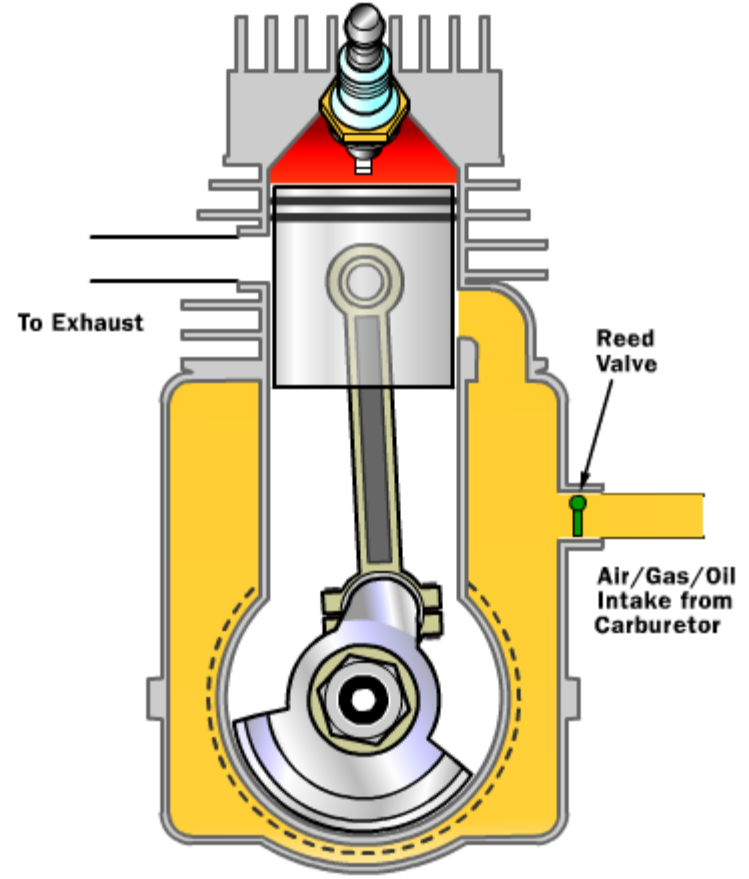

To Exhaust

Reed Valve

Air/Gas/Oil Intake from Carburetor

Inside a Two-stroke Engine

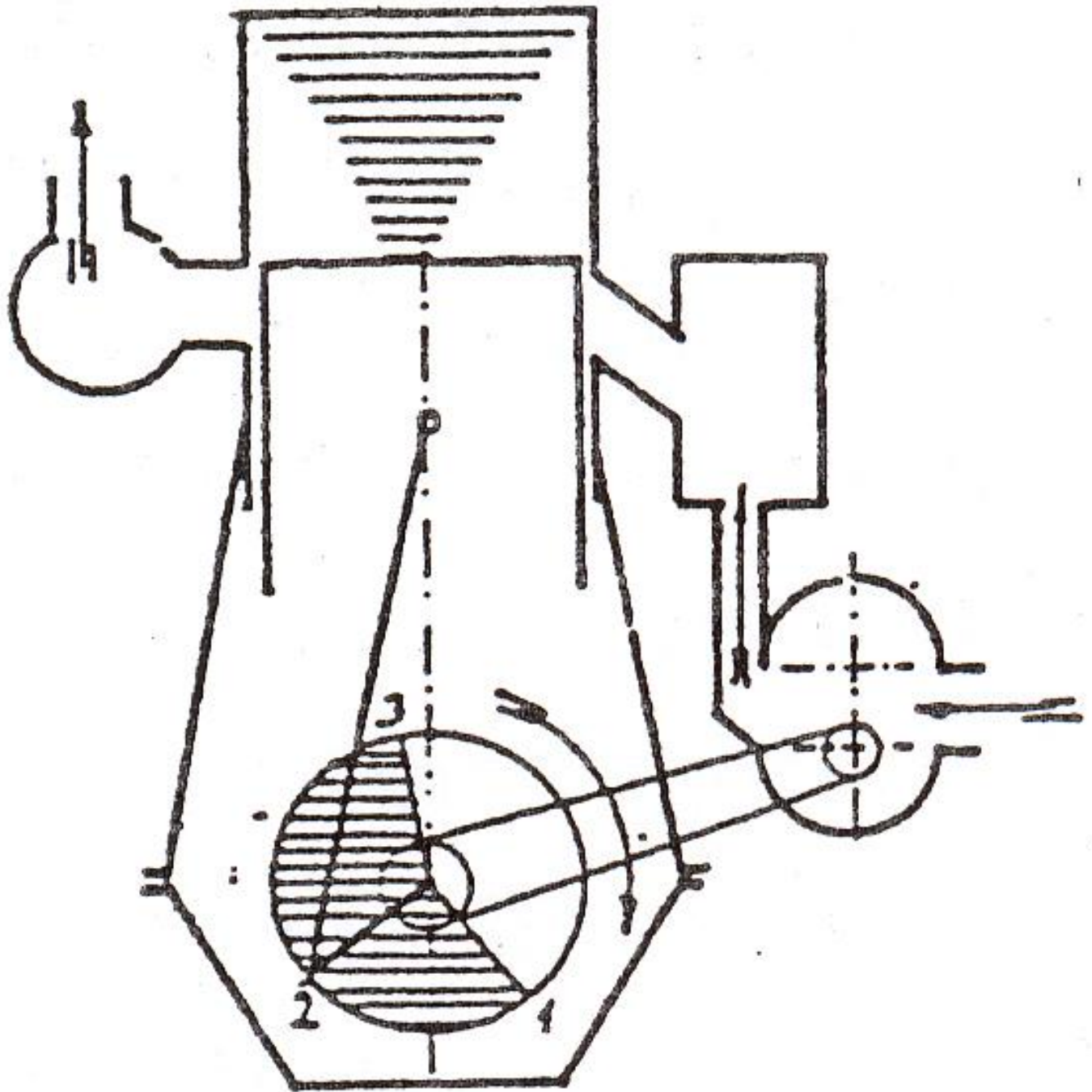

GM díselvél

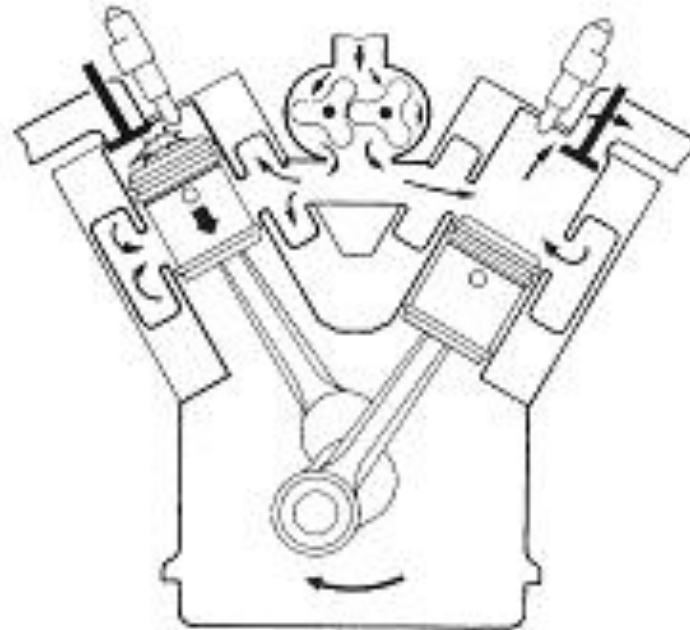
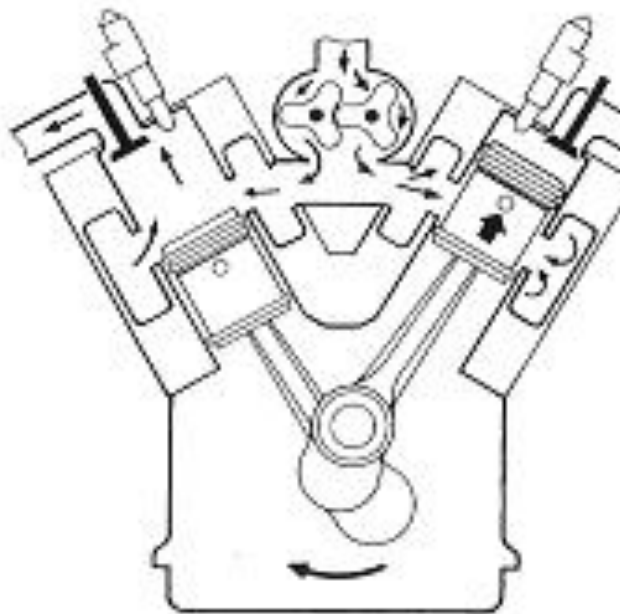

GM - dísel

- ❑ Skoloftsblásari
- ❑ Ventlar
- ❑ toppskolun

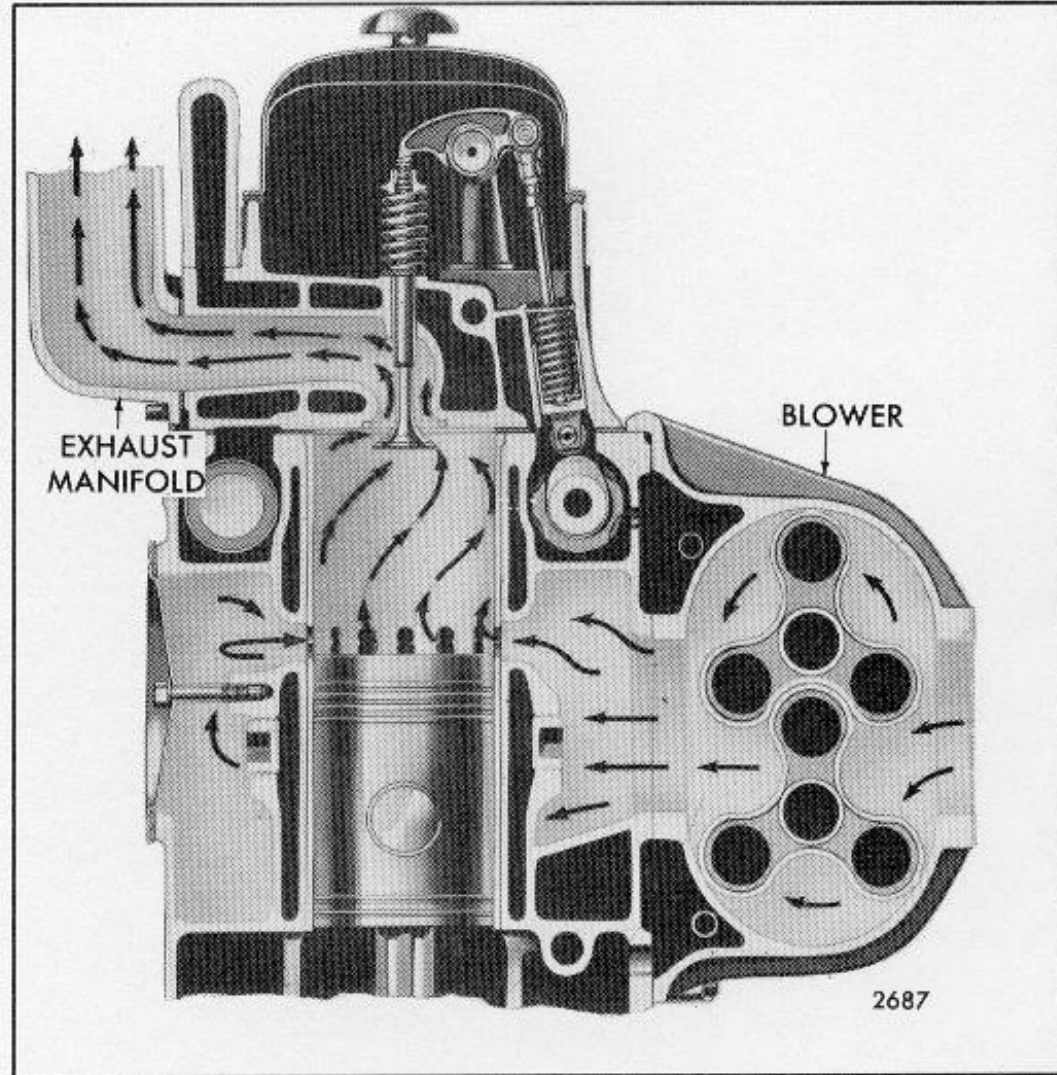
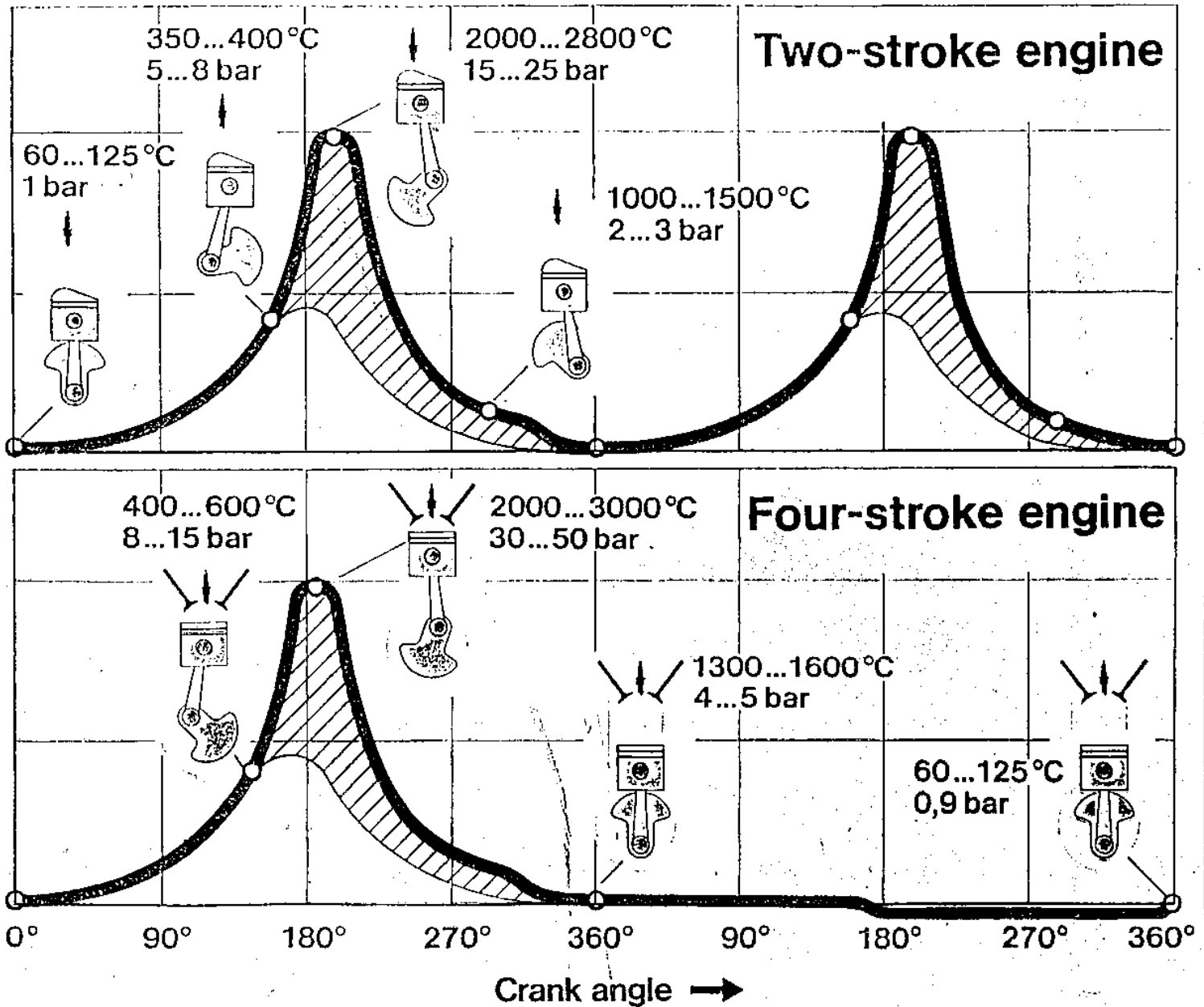

Fig. 1 - Air Flow Through Blower and Engine

Pressure and temperature loading





Blackstone

- ❑ Fjörgengisvél
- ❑ Loftið fer inn um soglokann og gasið út um útblásturslokann
- ❑ Lokarnir eru í strokklokinu (heddinu)

E L E N G I N E S

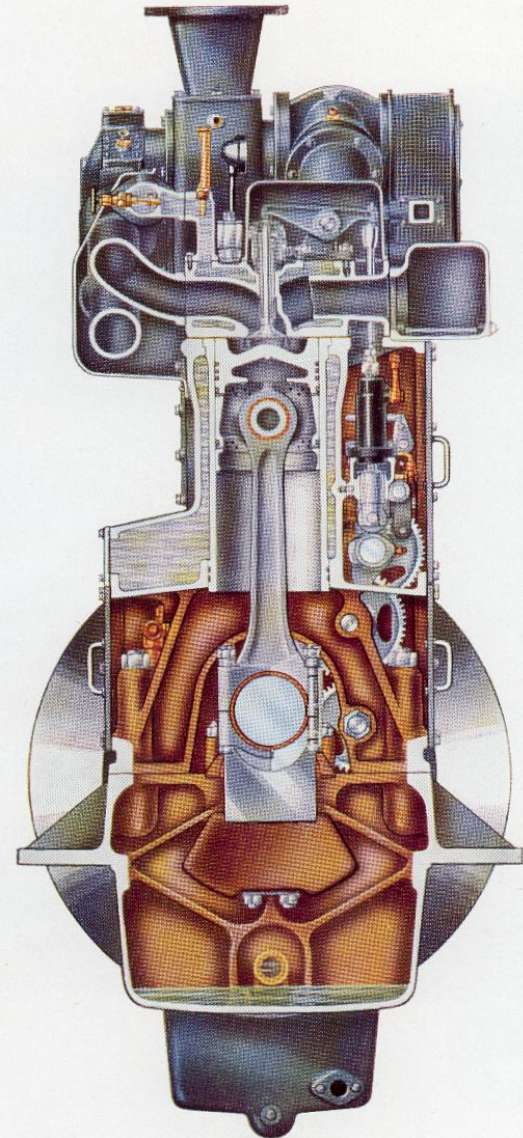

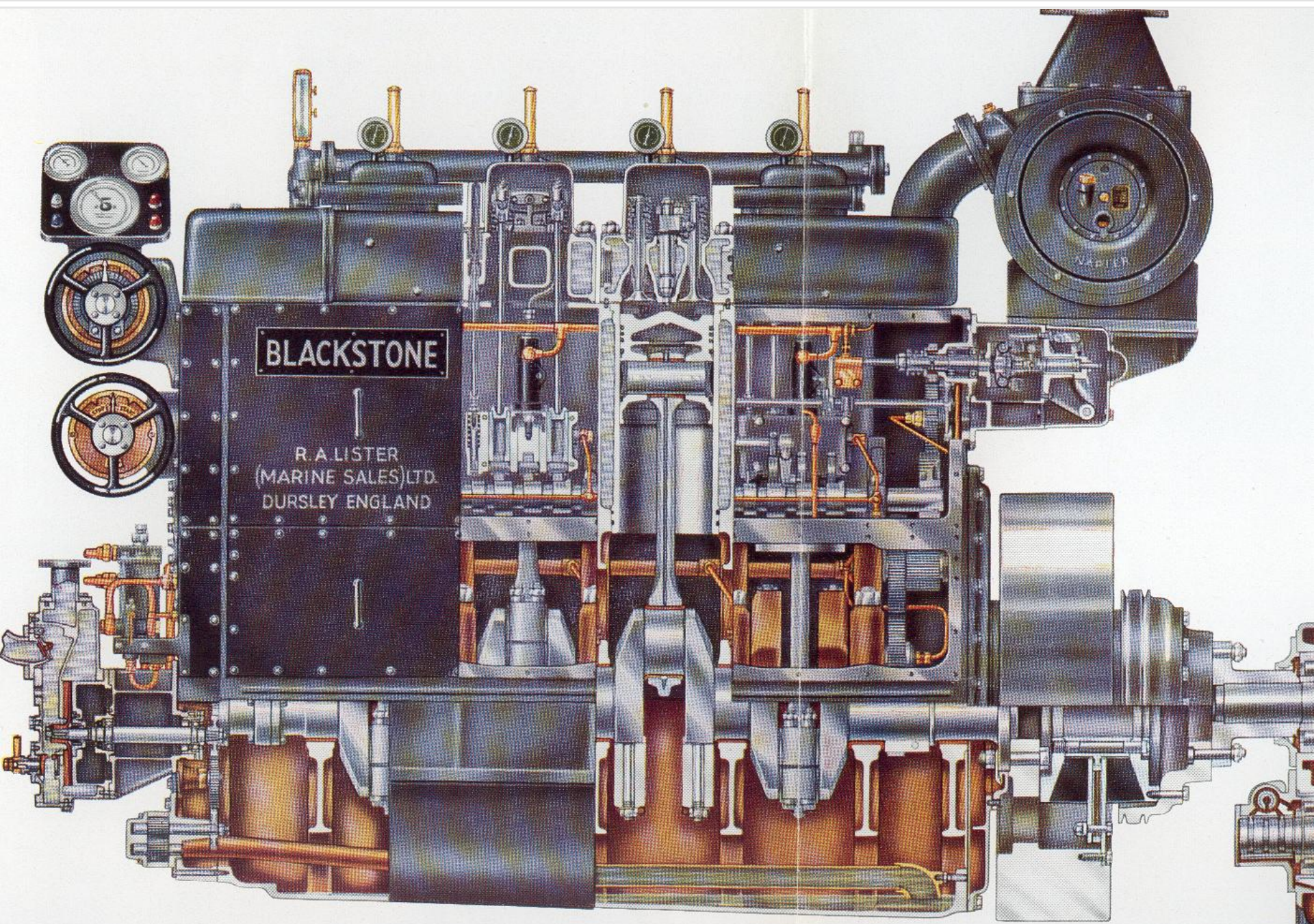

BLACKSTONE

R. A. LISTER
(MARINE SALES) LTD.
DURSLEY ENGLAND

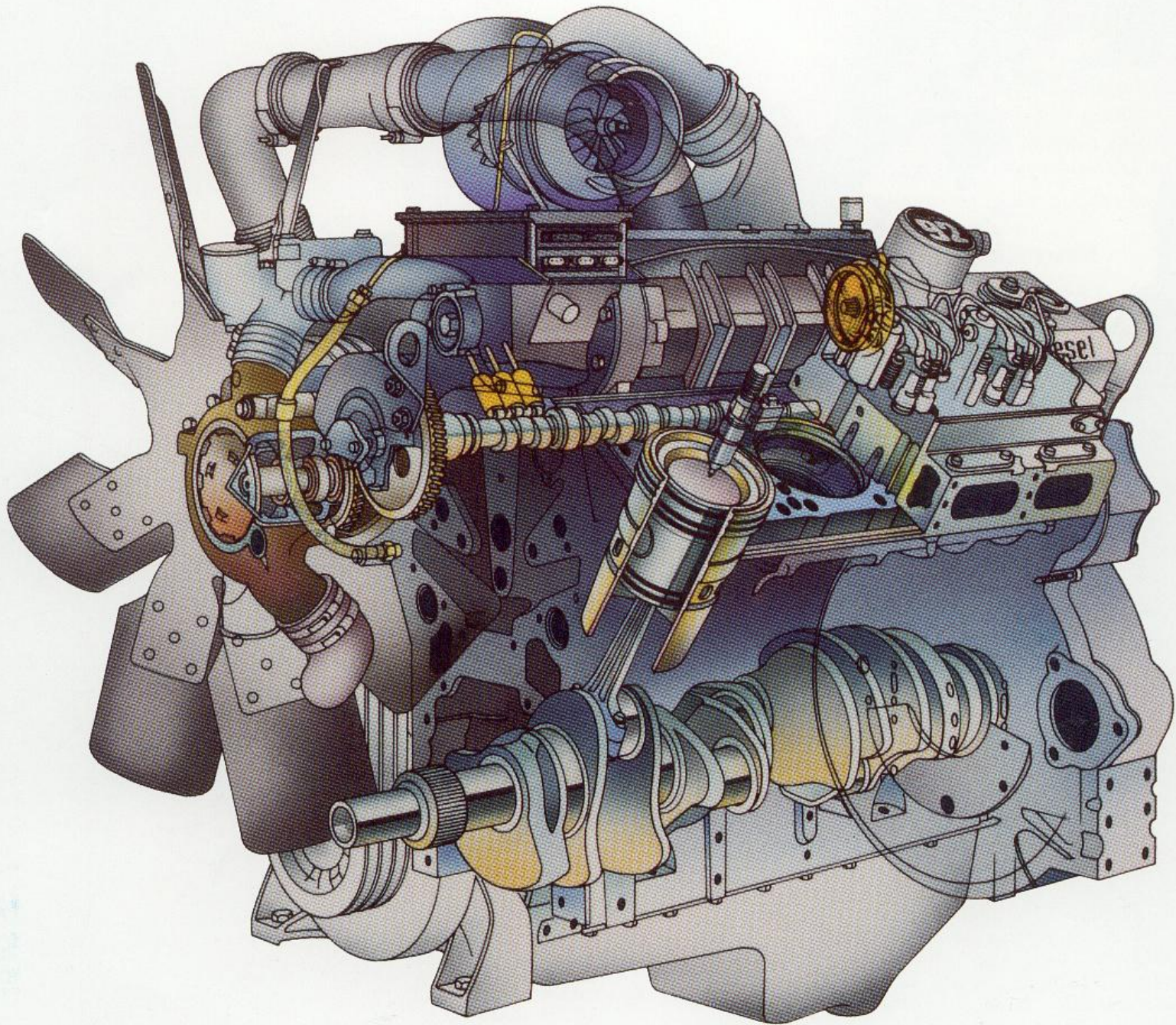



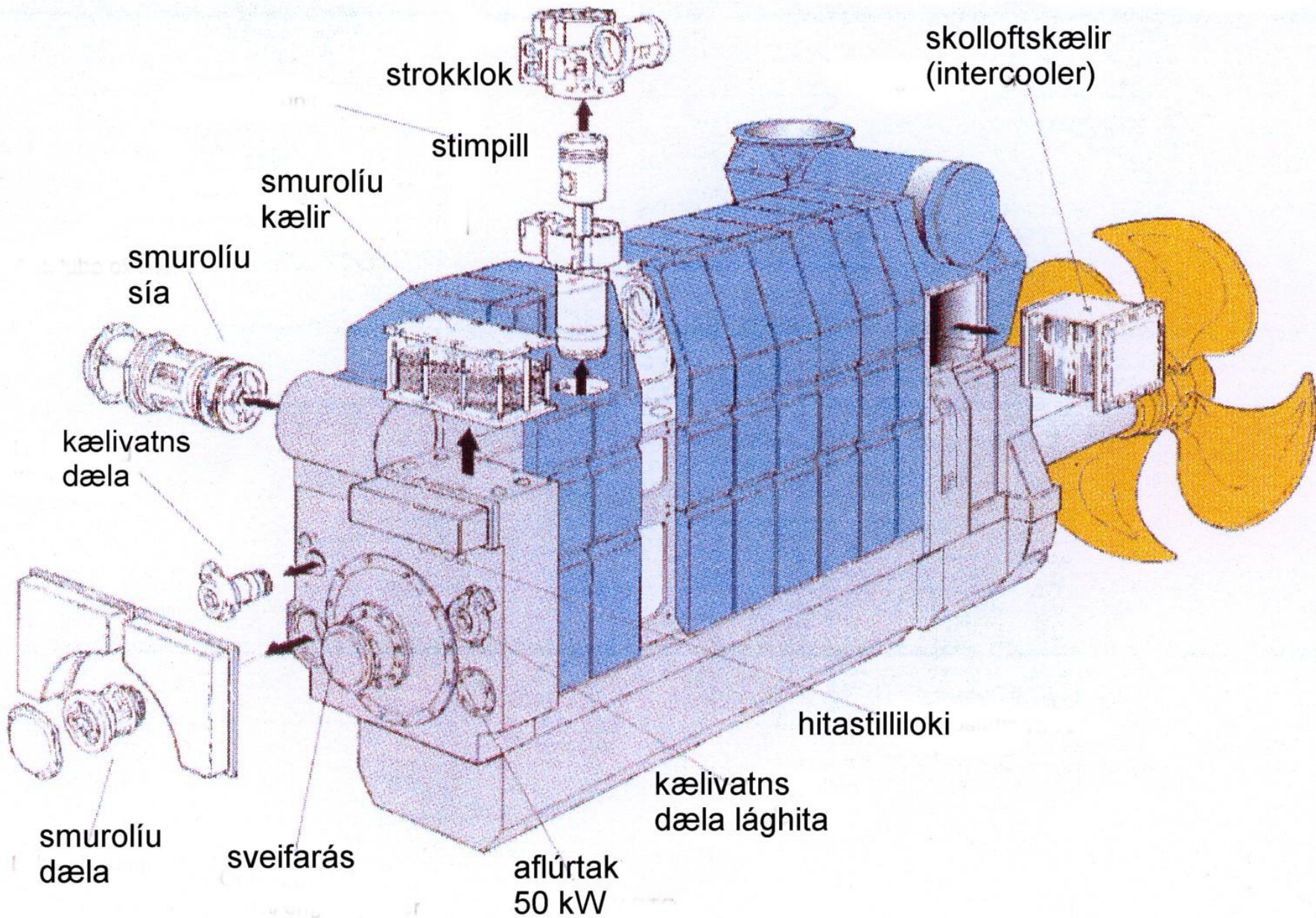



Guðmundi

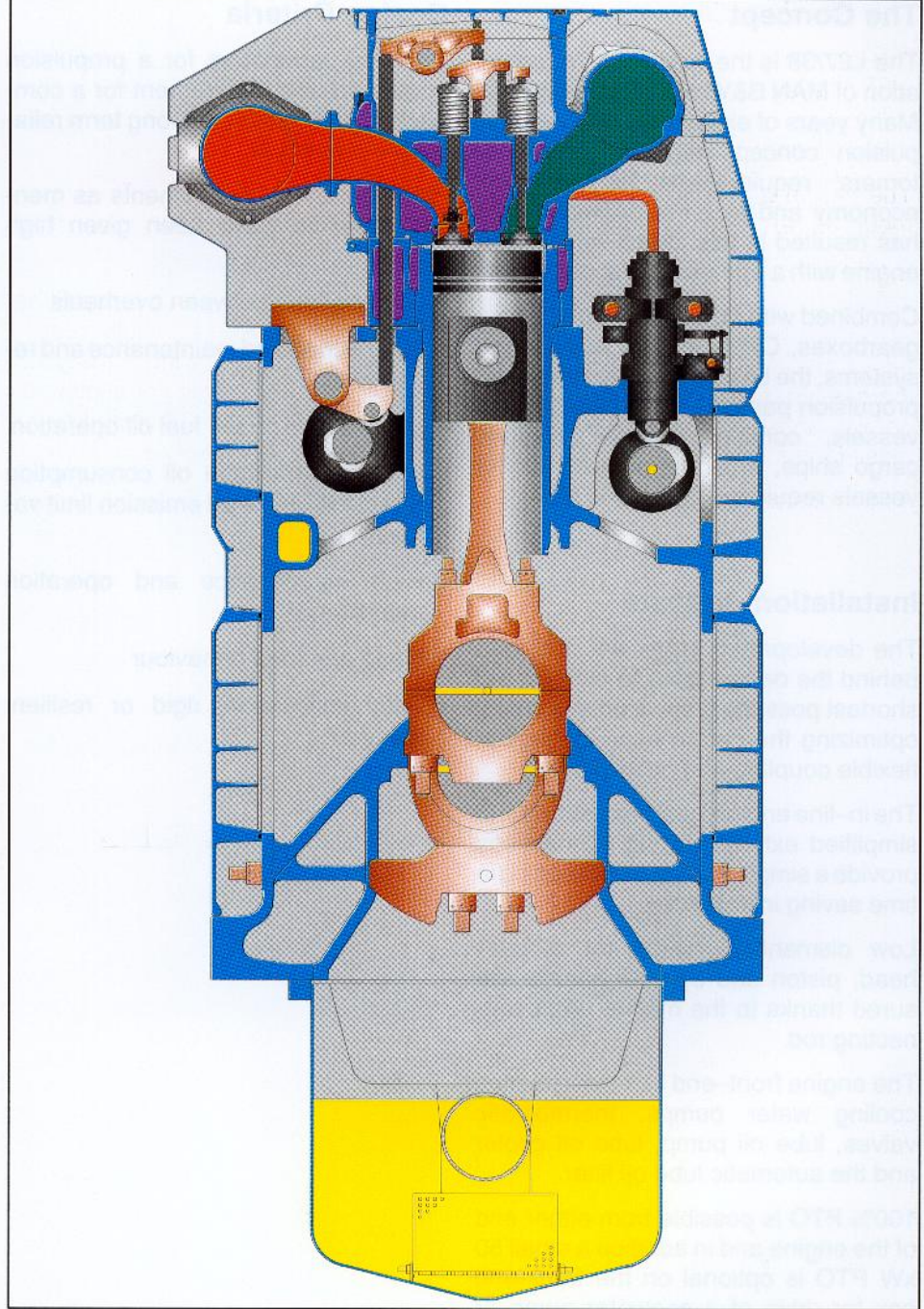
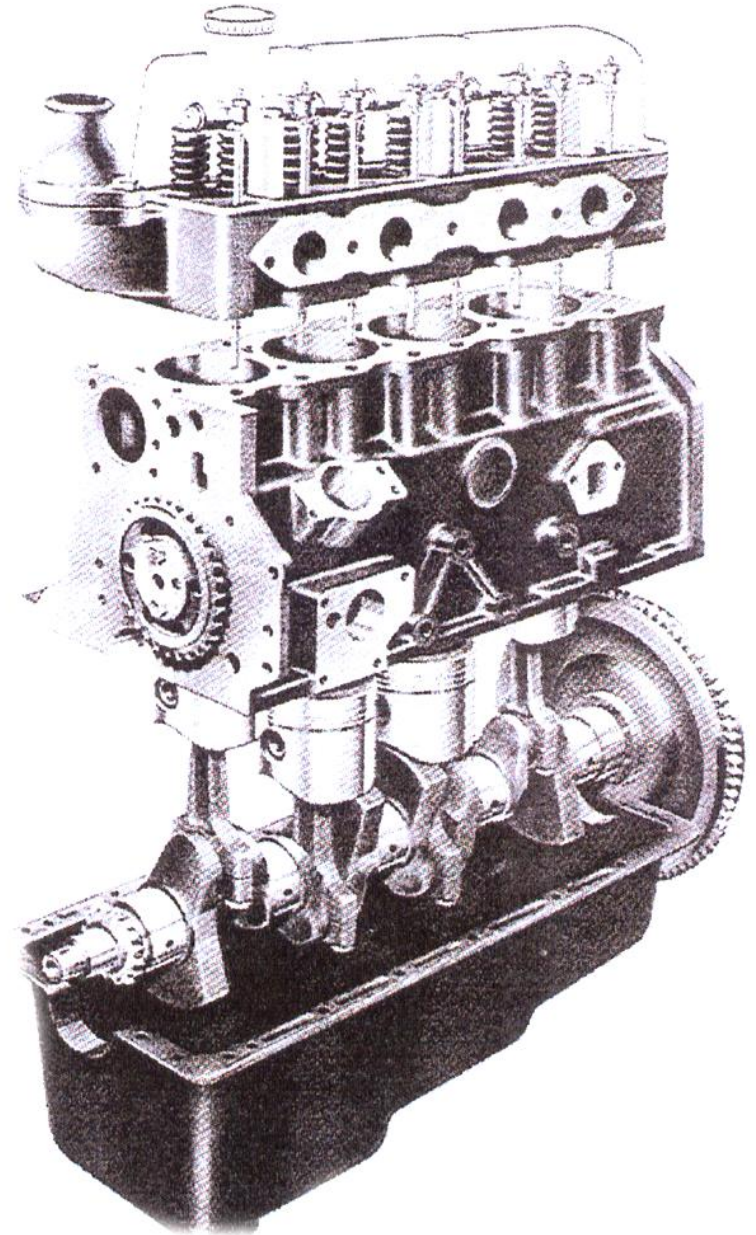
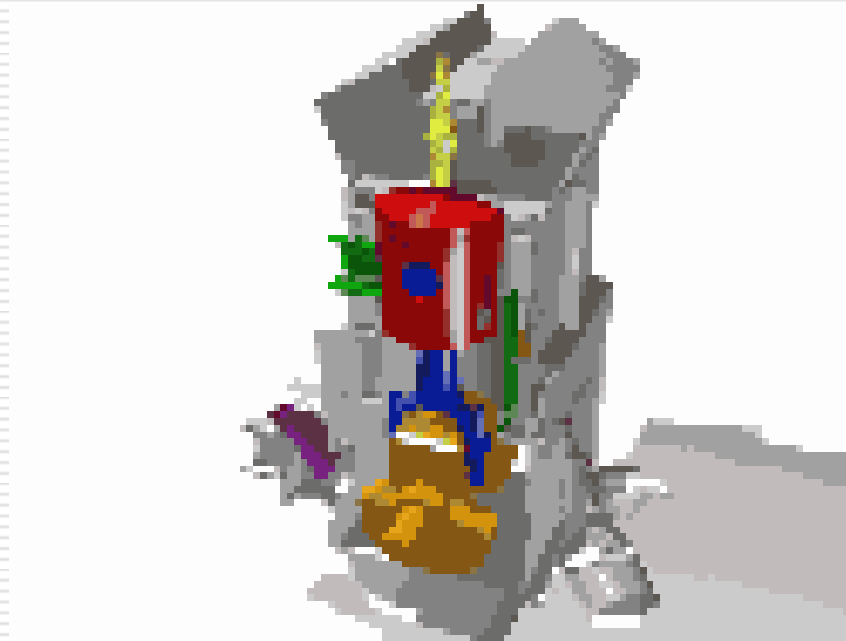

Fig 1 Cross section of engine

-
- Efst er strokklokið
 - Síðan blokkin
 - Svo er sveifarhúsið



Fer í gang



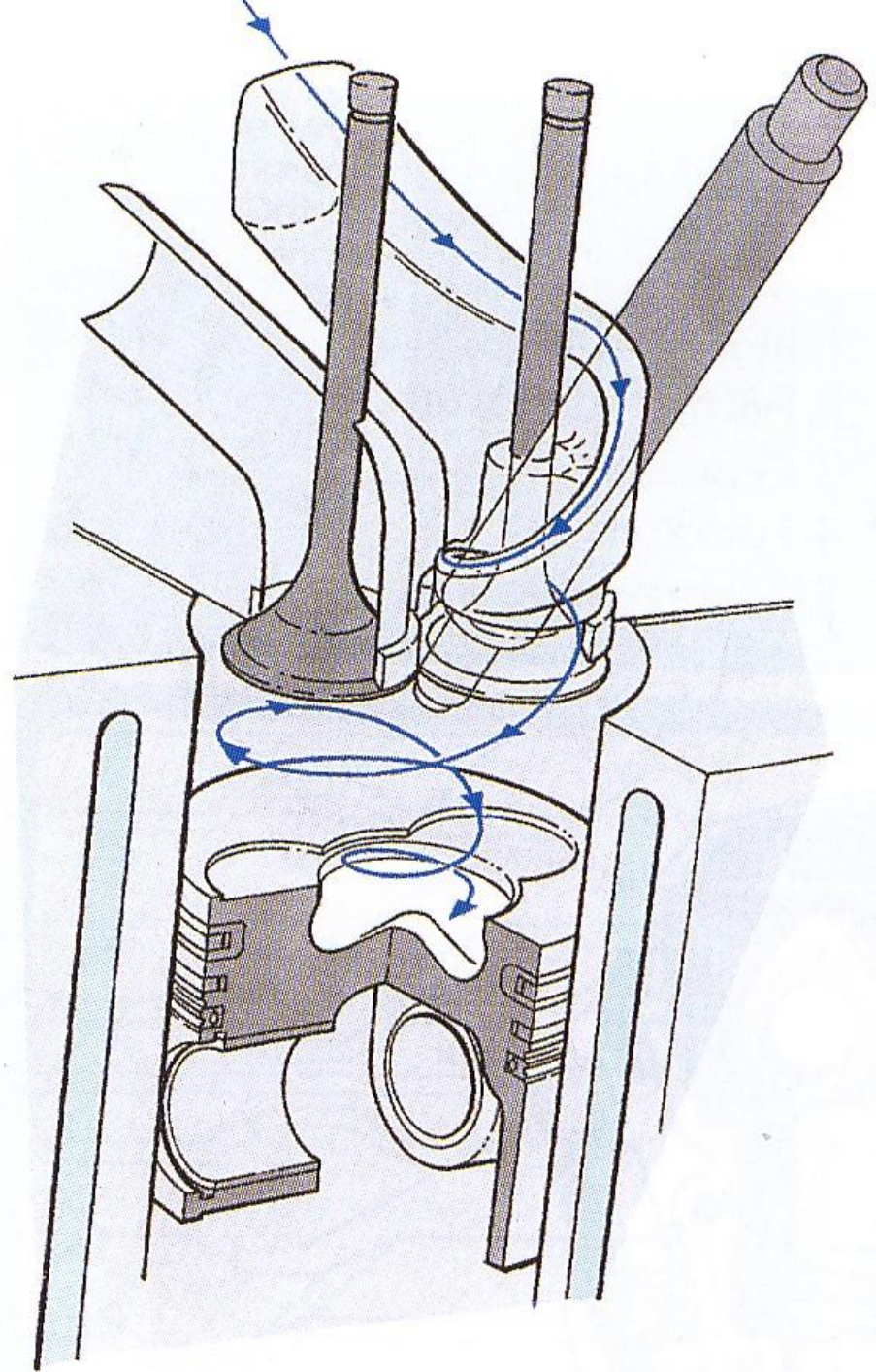

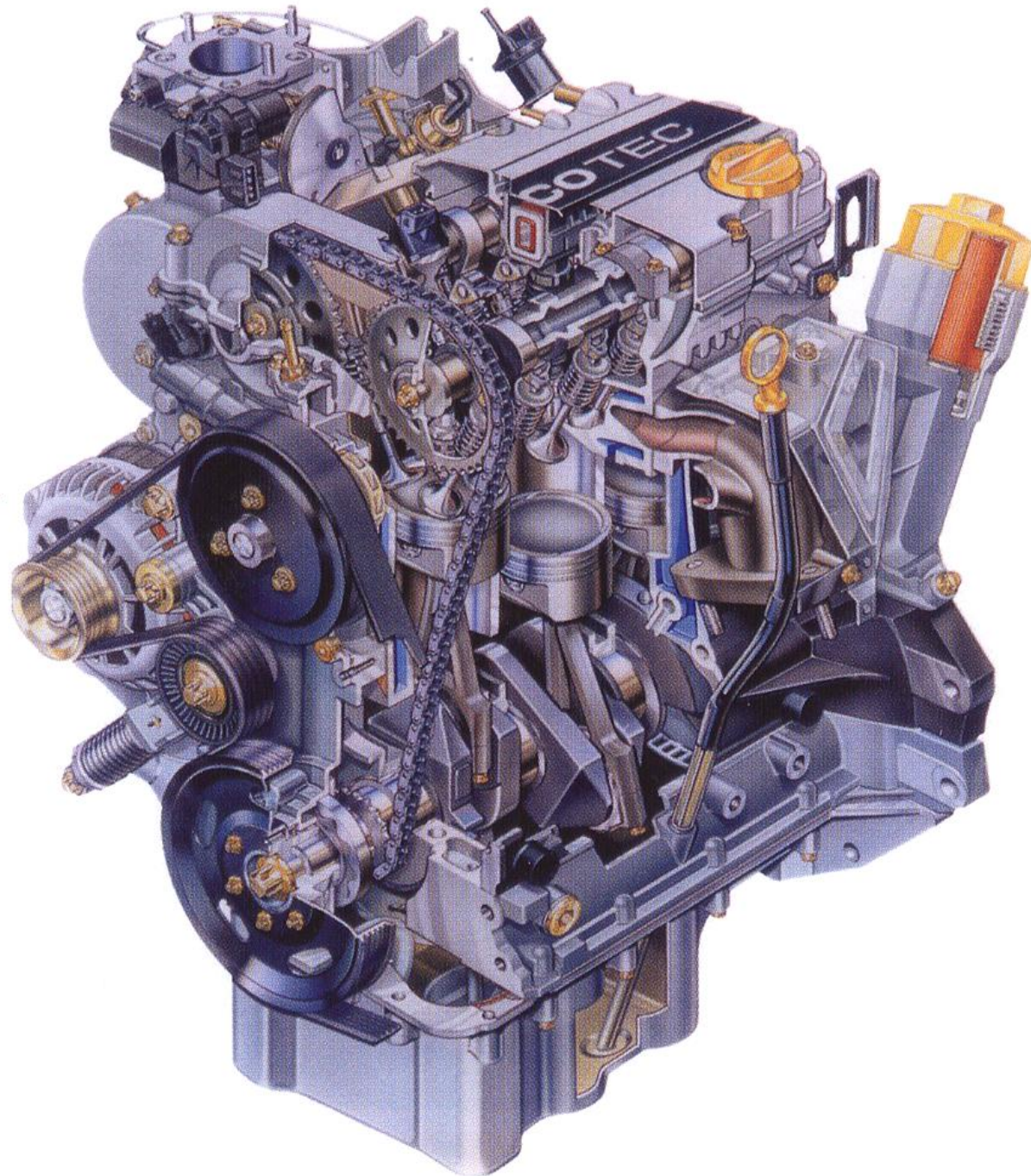

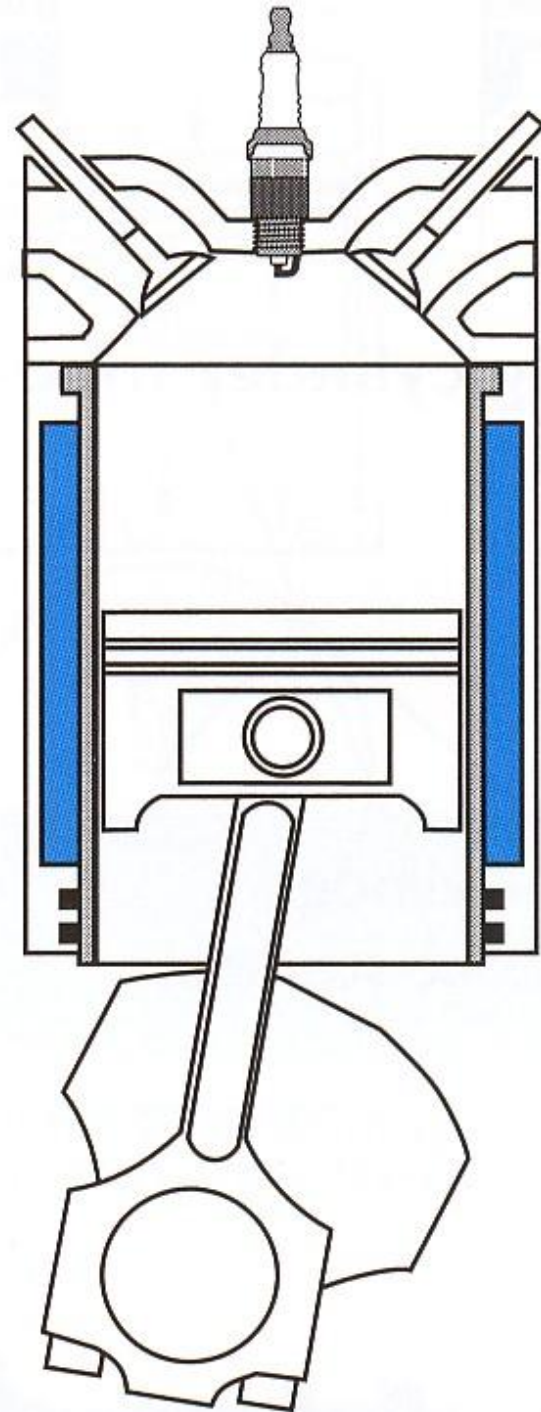
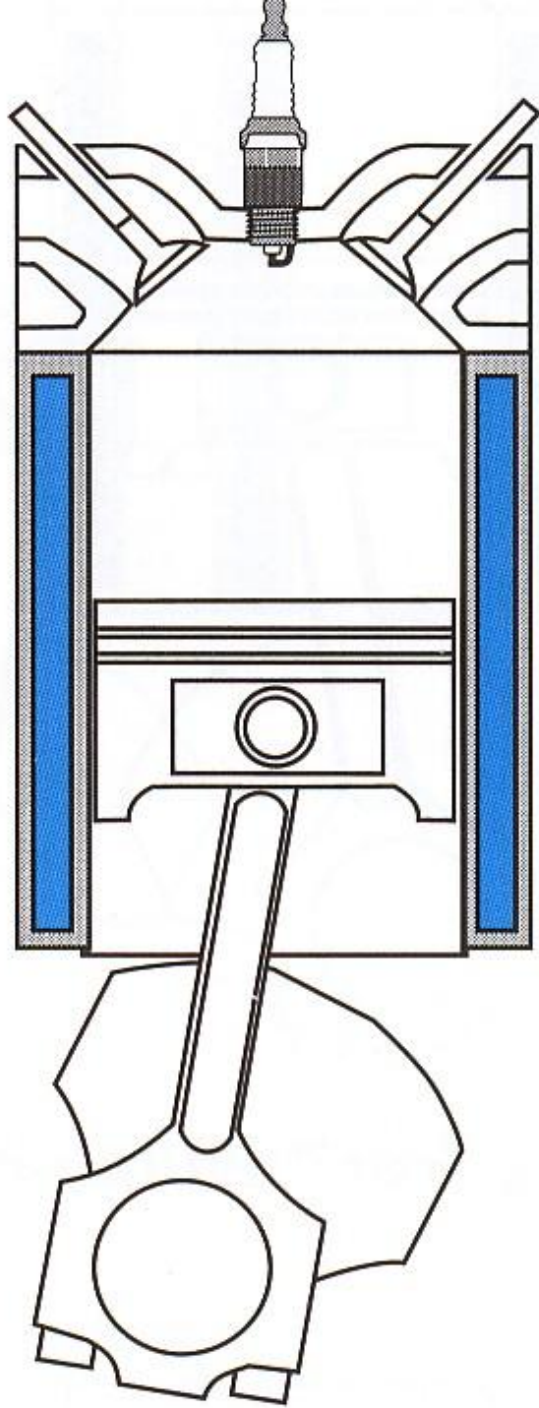

inars:

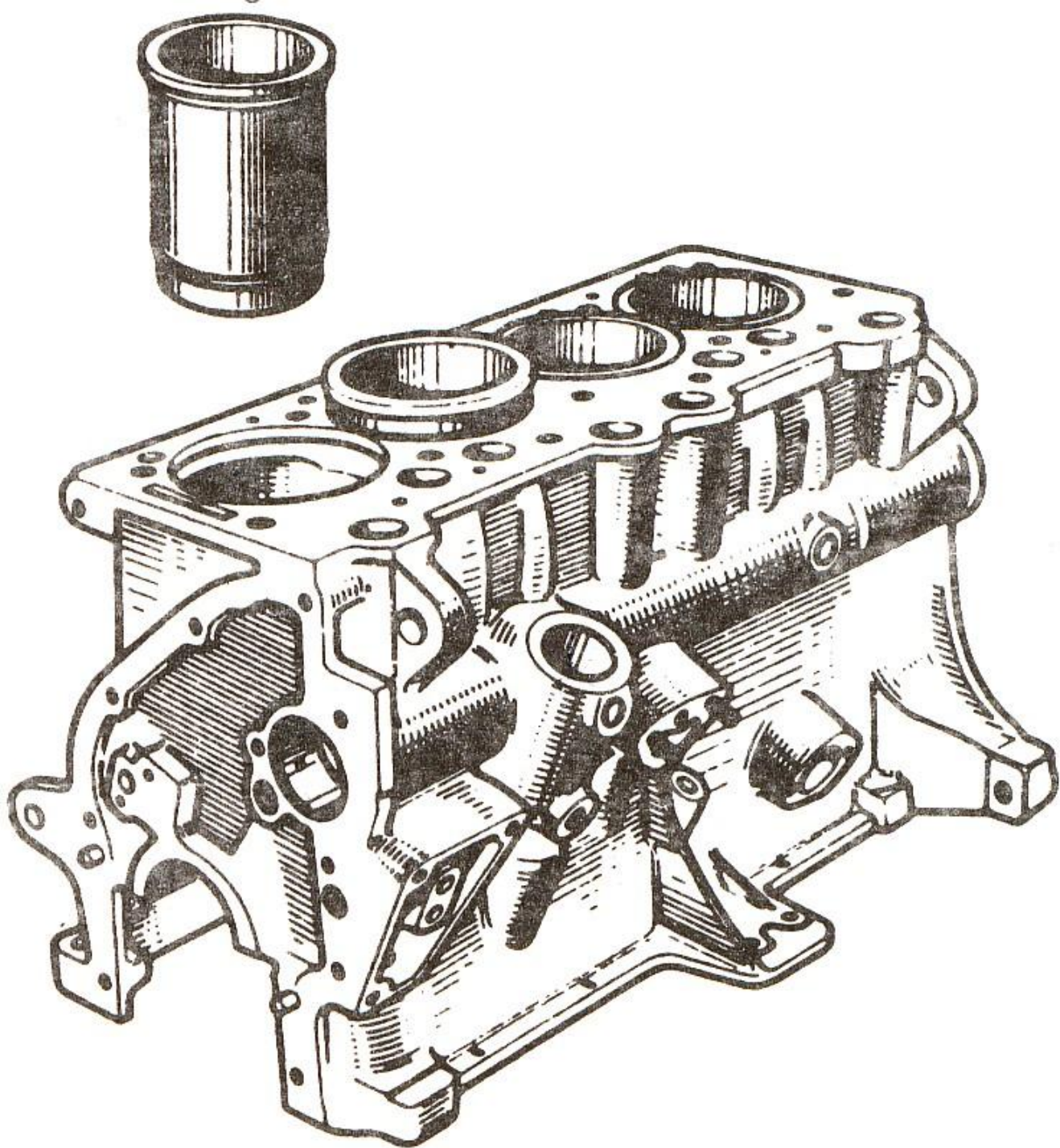

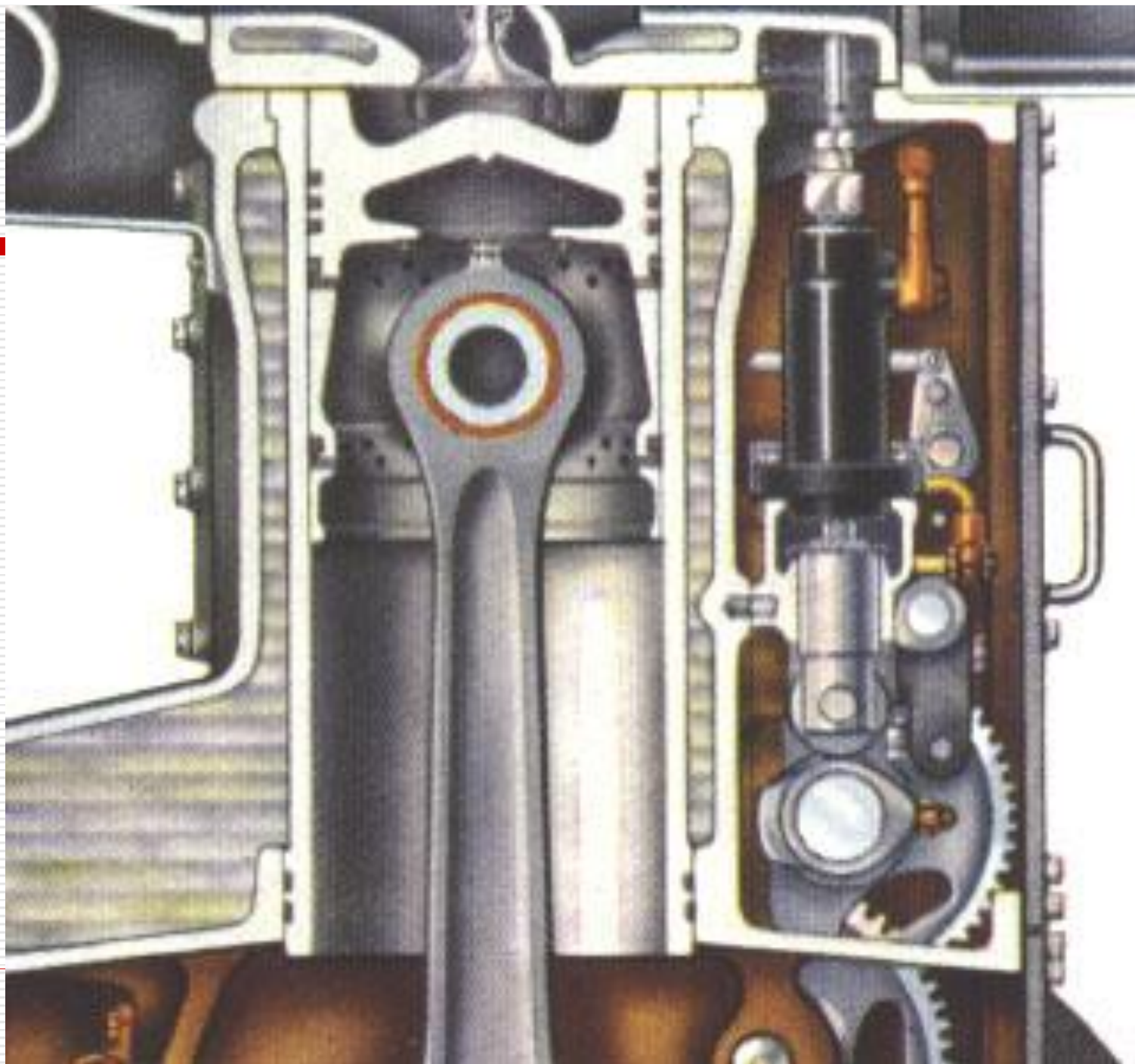

Cylinder liner.

- ❑ Slíf úr tvígangisvél loftið kemur inn um götin, gasið fer upp og út um útblásturslokana, þeir eru oftast fjórir.
- ❑ Þetta er toppskolun

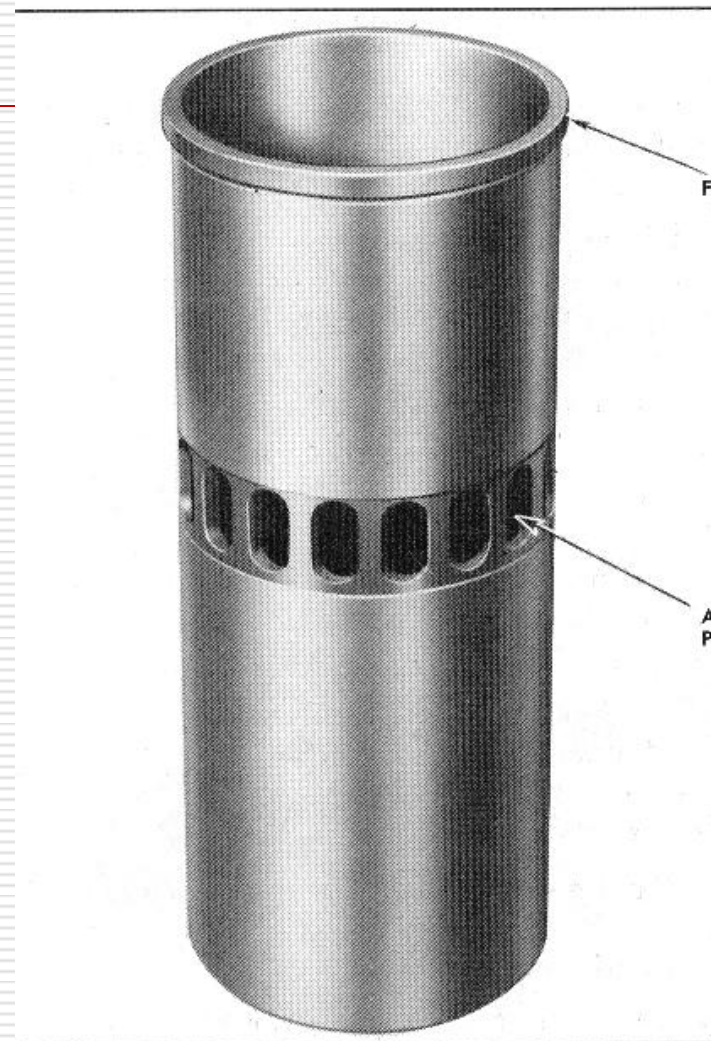
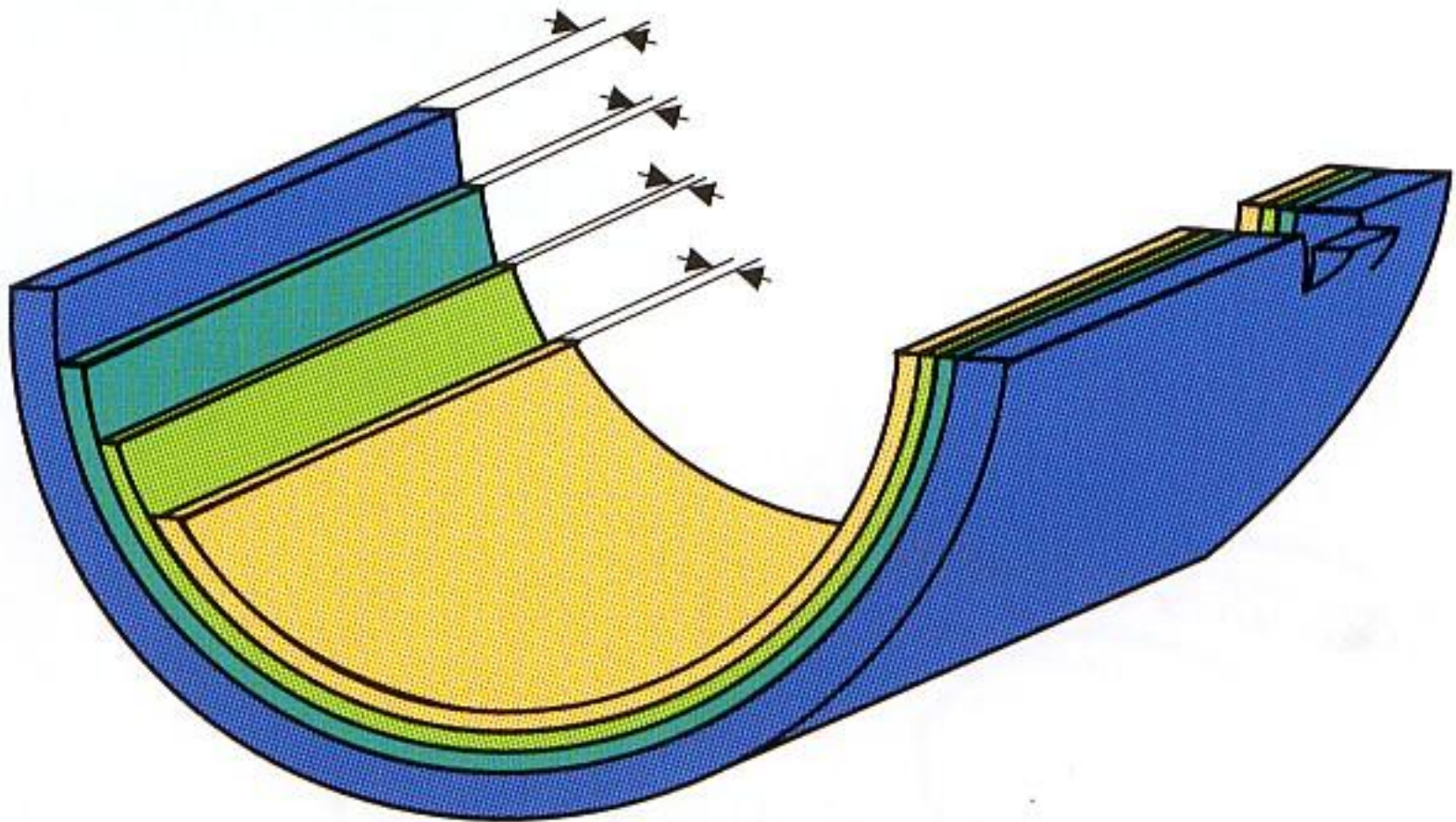

Fig. 1 – Typical Cylinder Liner

Legubakkar



Guðmundur Einarsson

Höfuðlegur

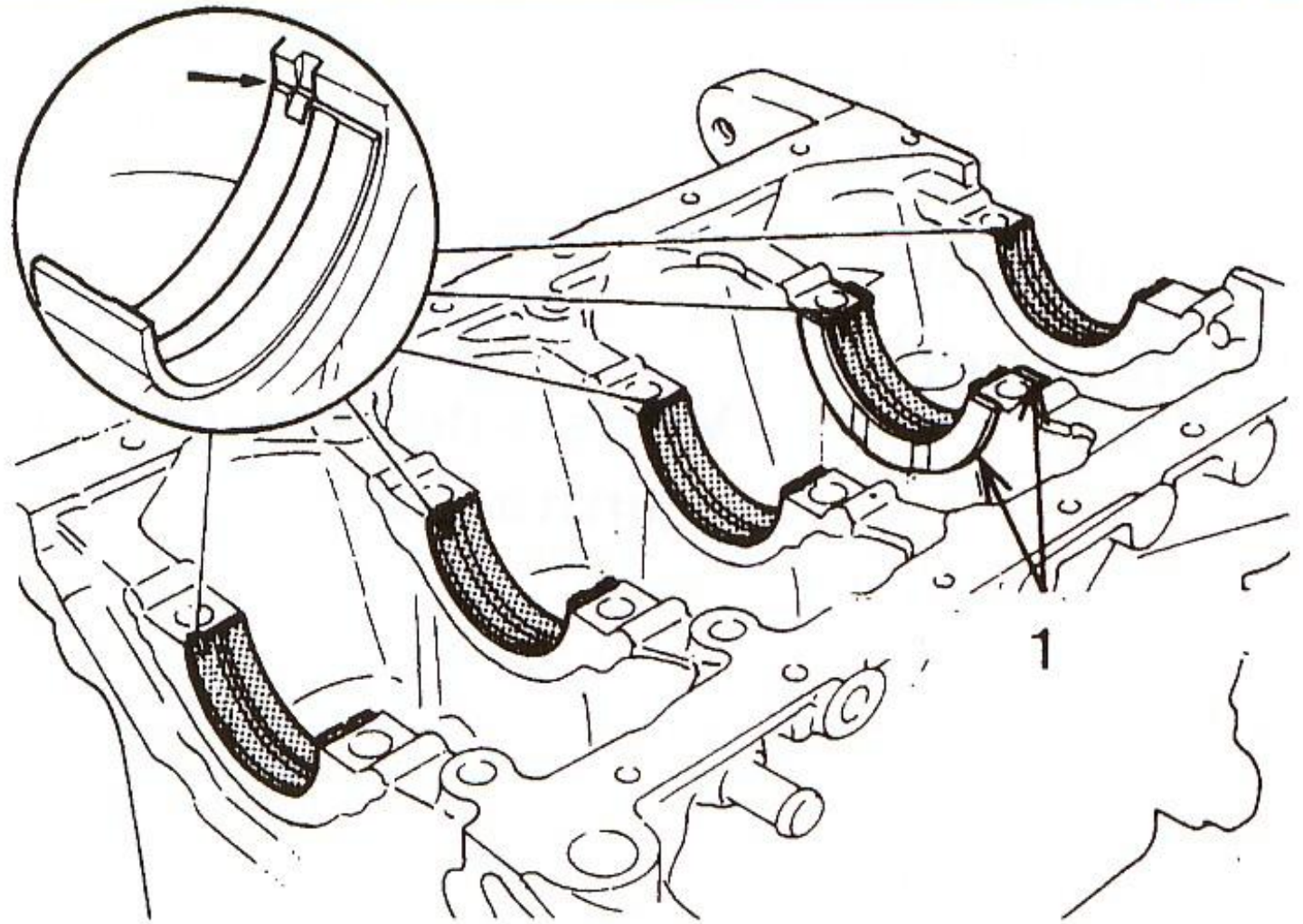

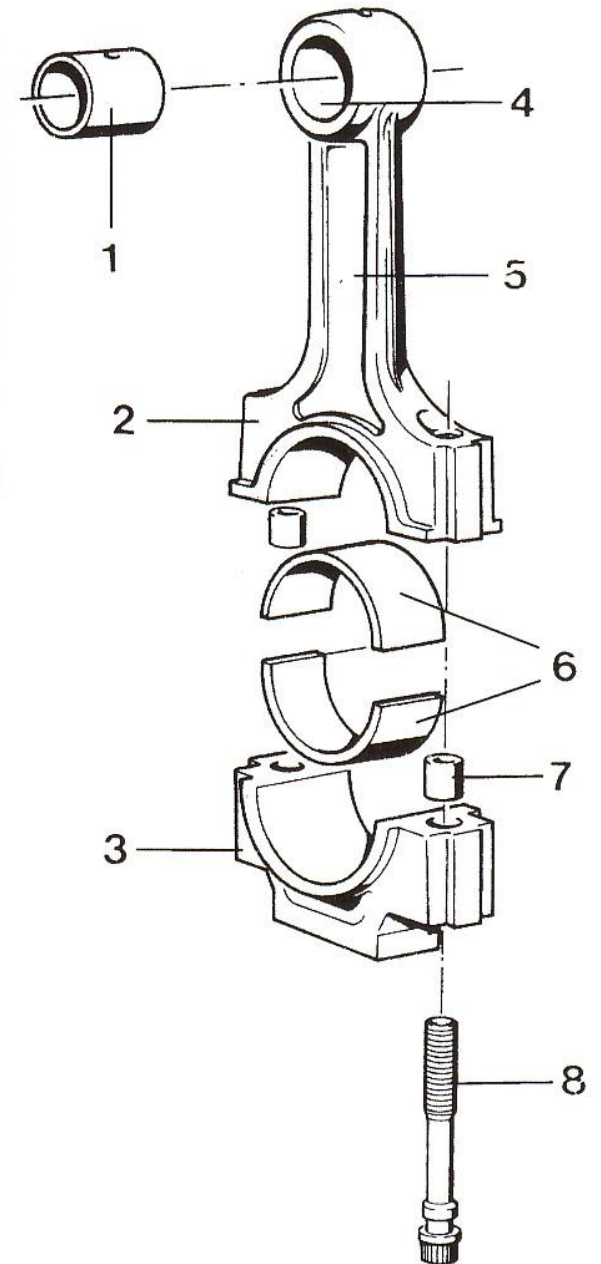
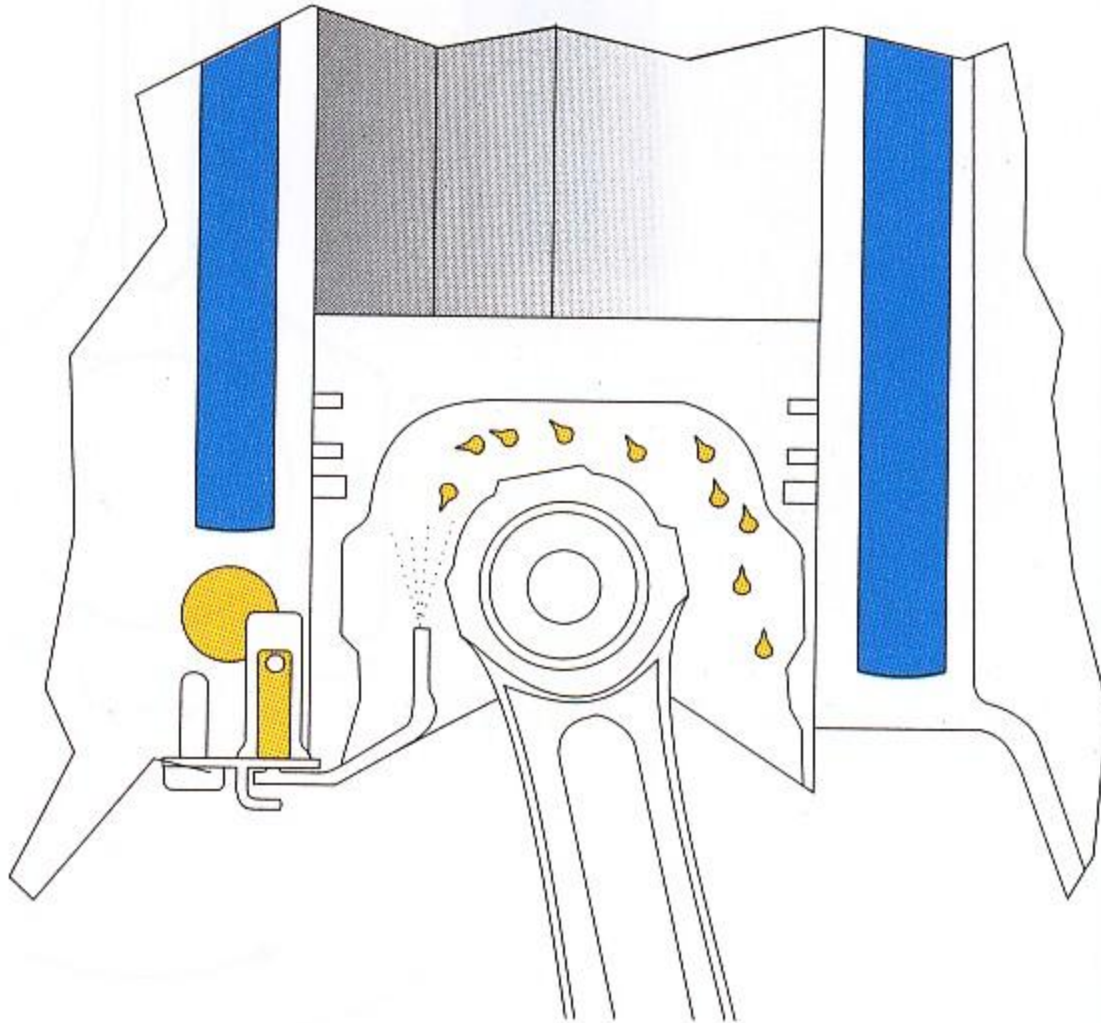

Stimpill

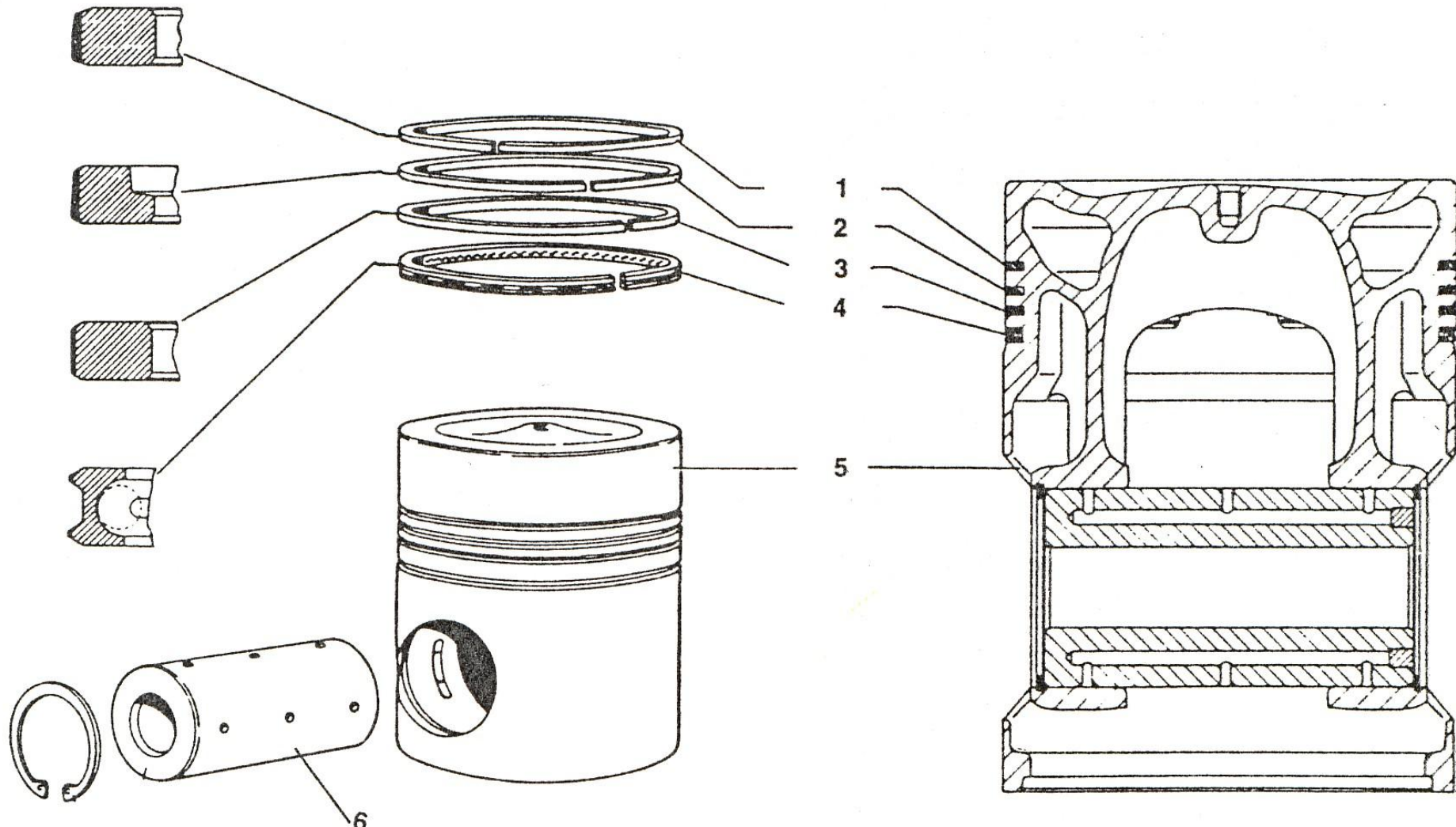

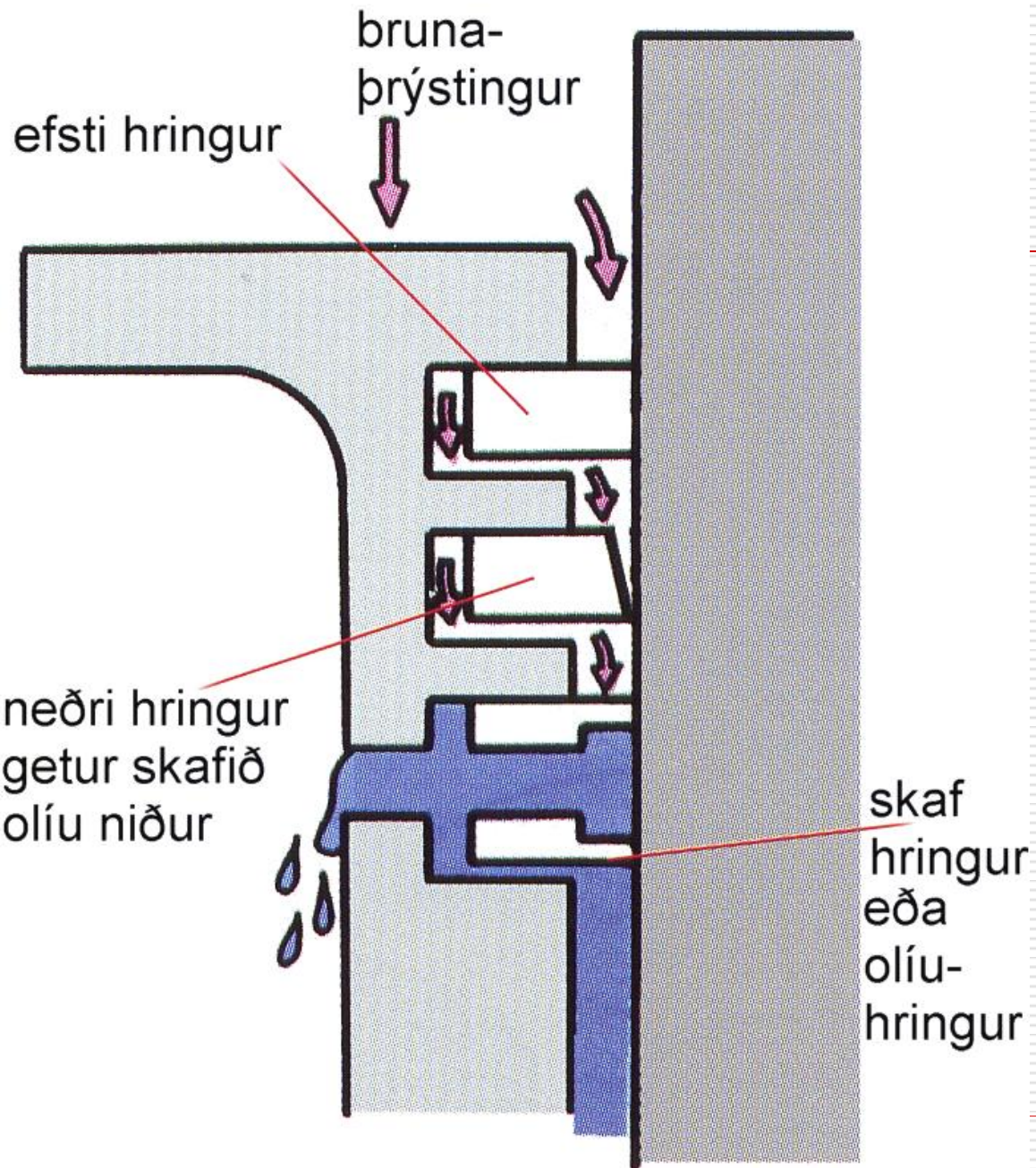

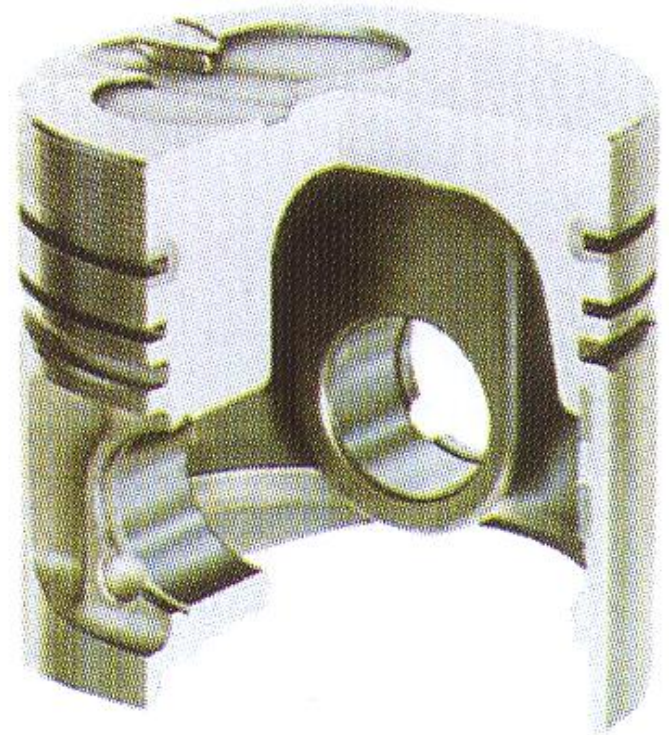
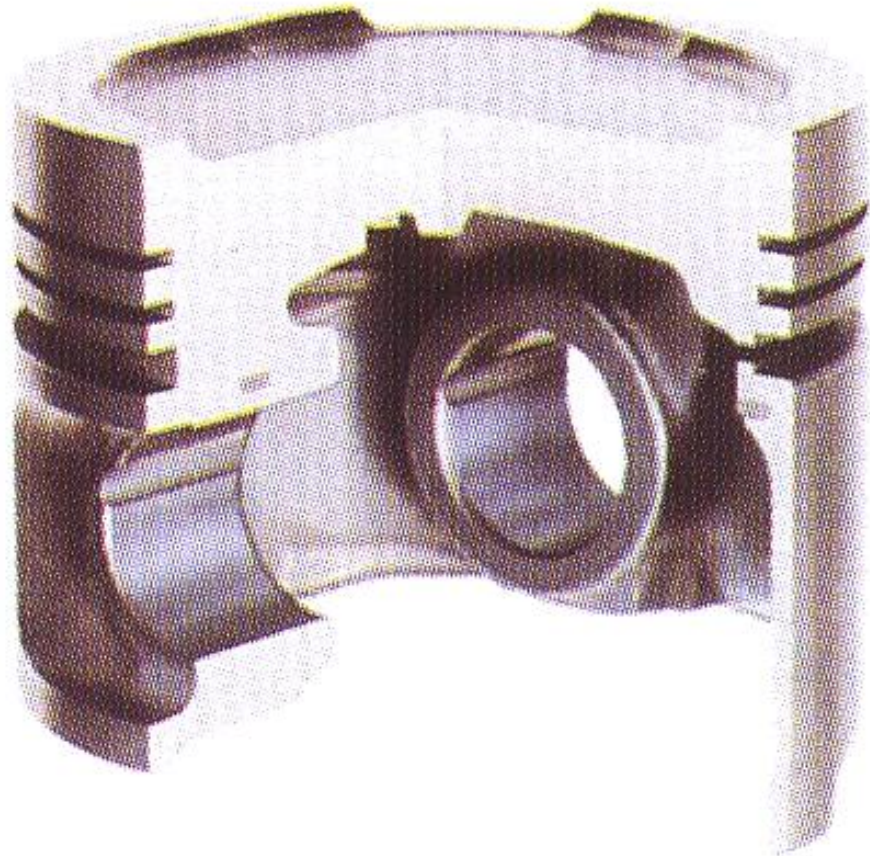

Sveifarás

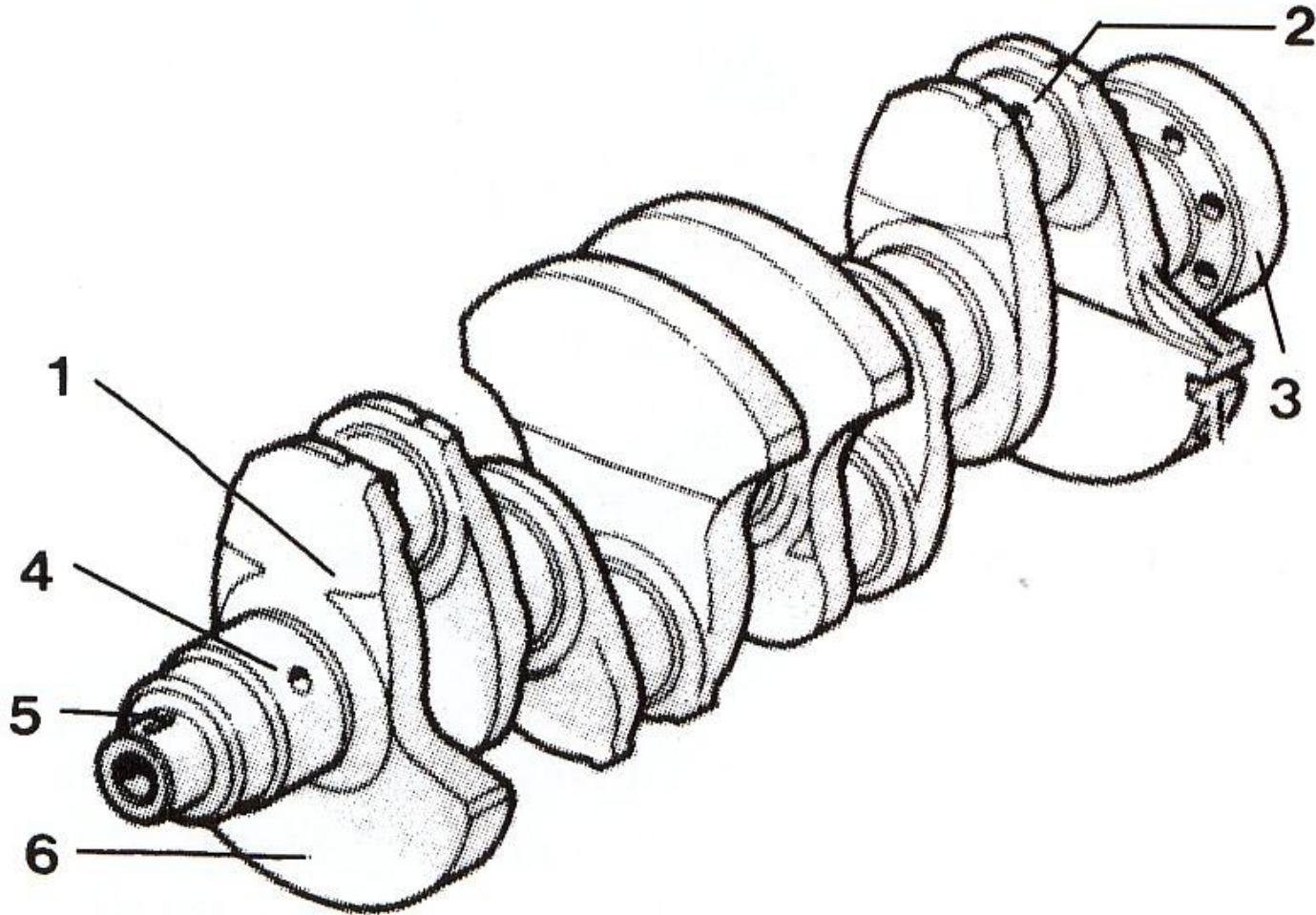

Titringsdeyfir

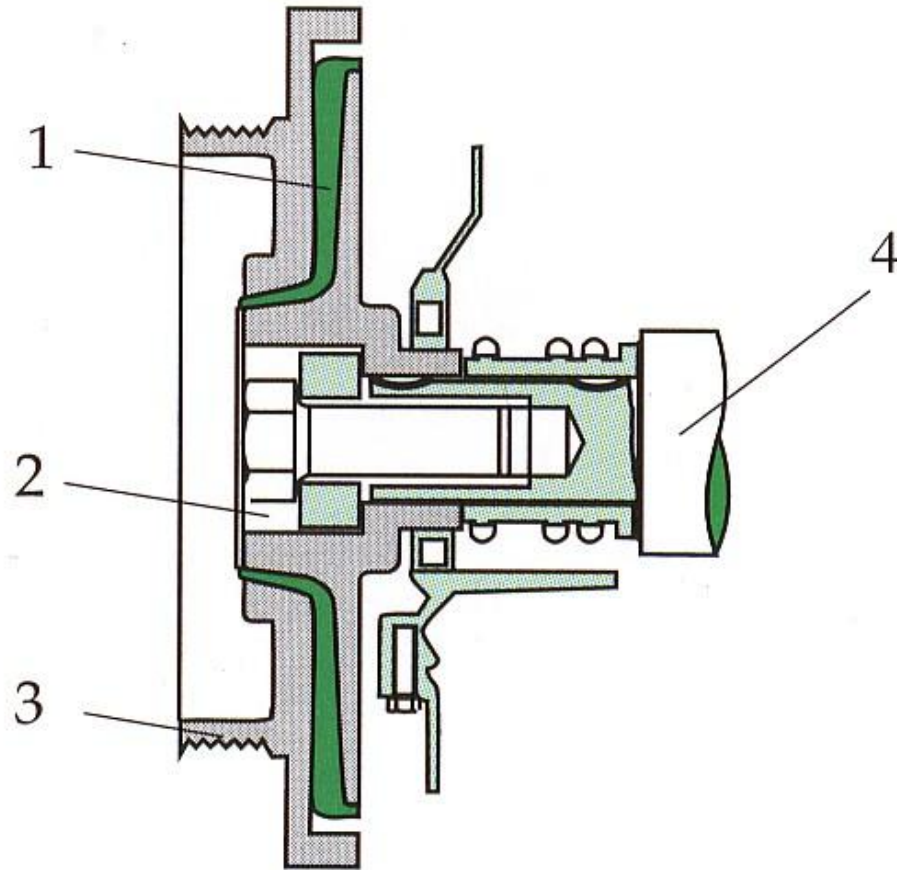

Sveifarás og titringsdeyfir

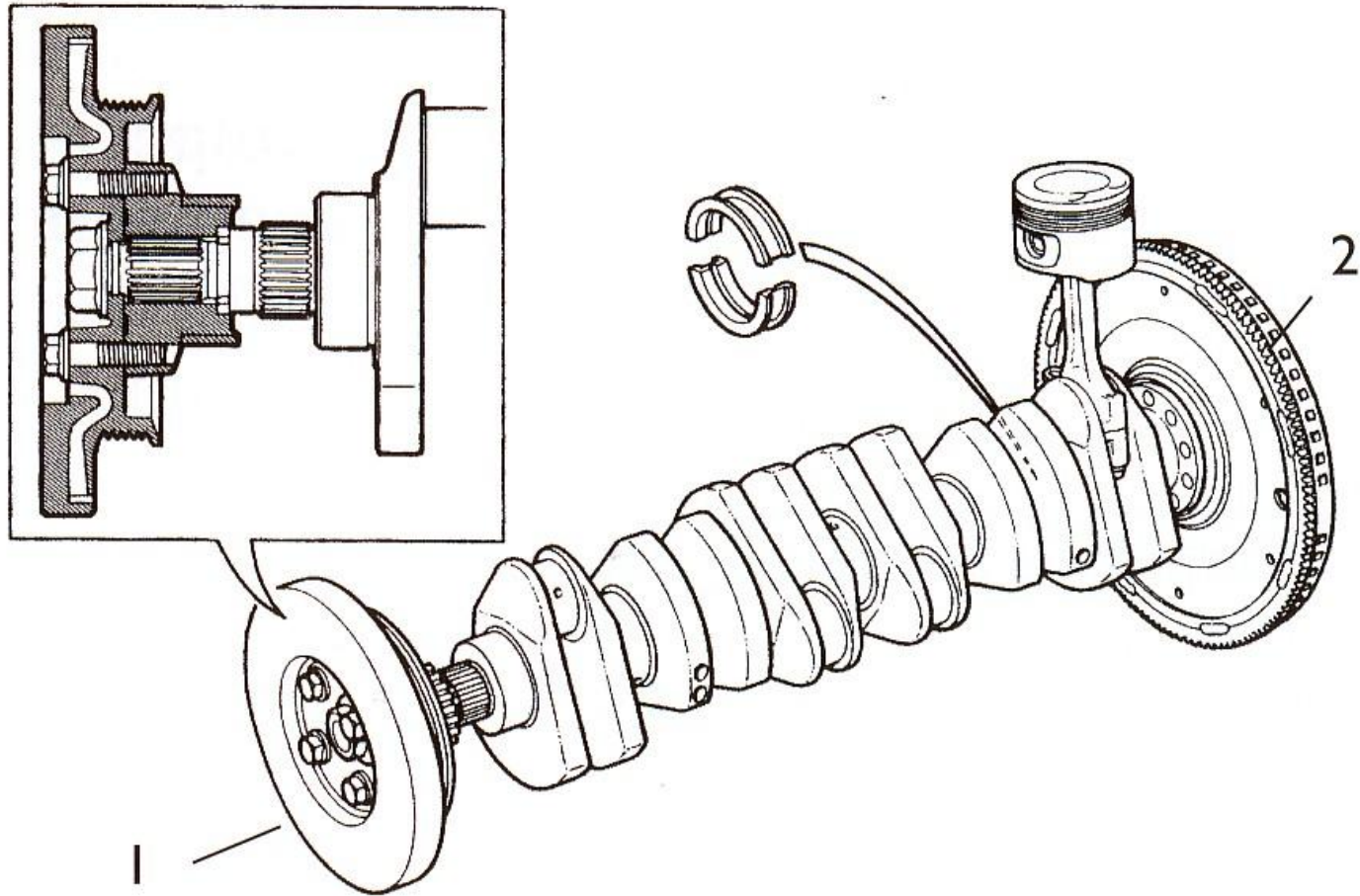

Pakkningar

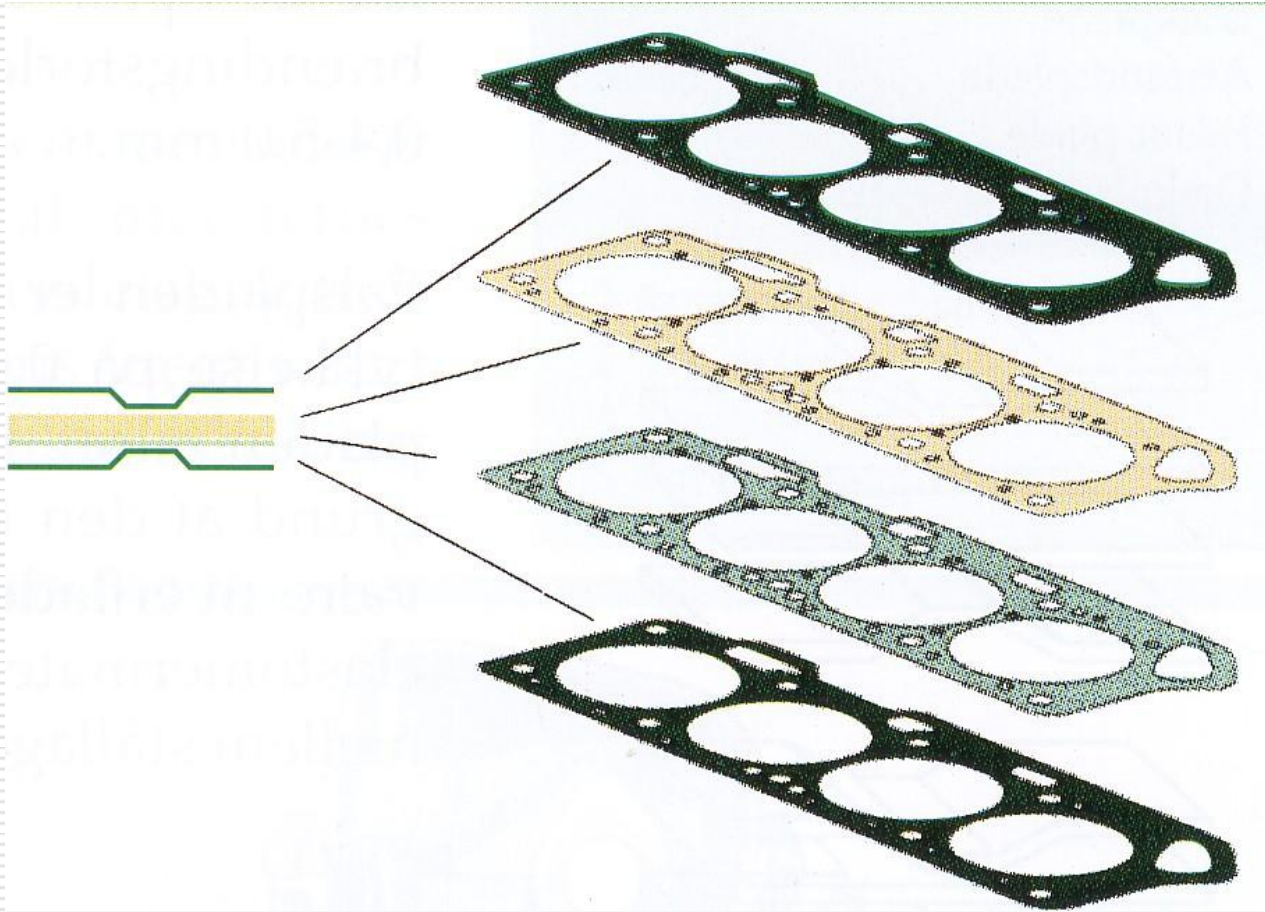

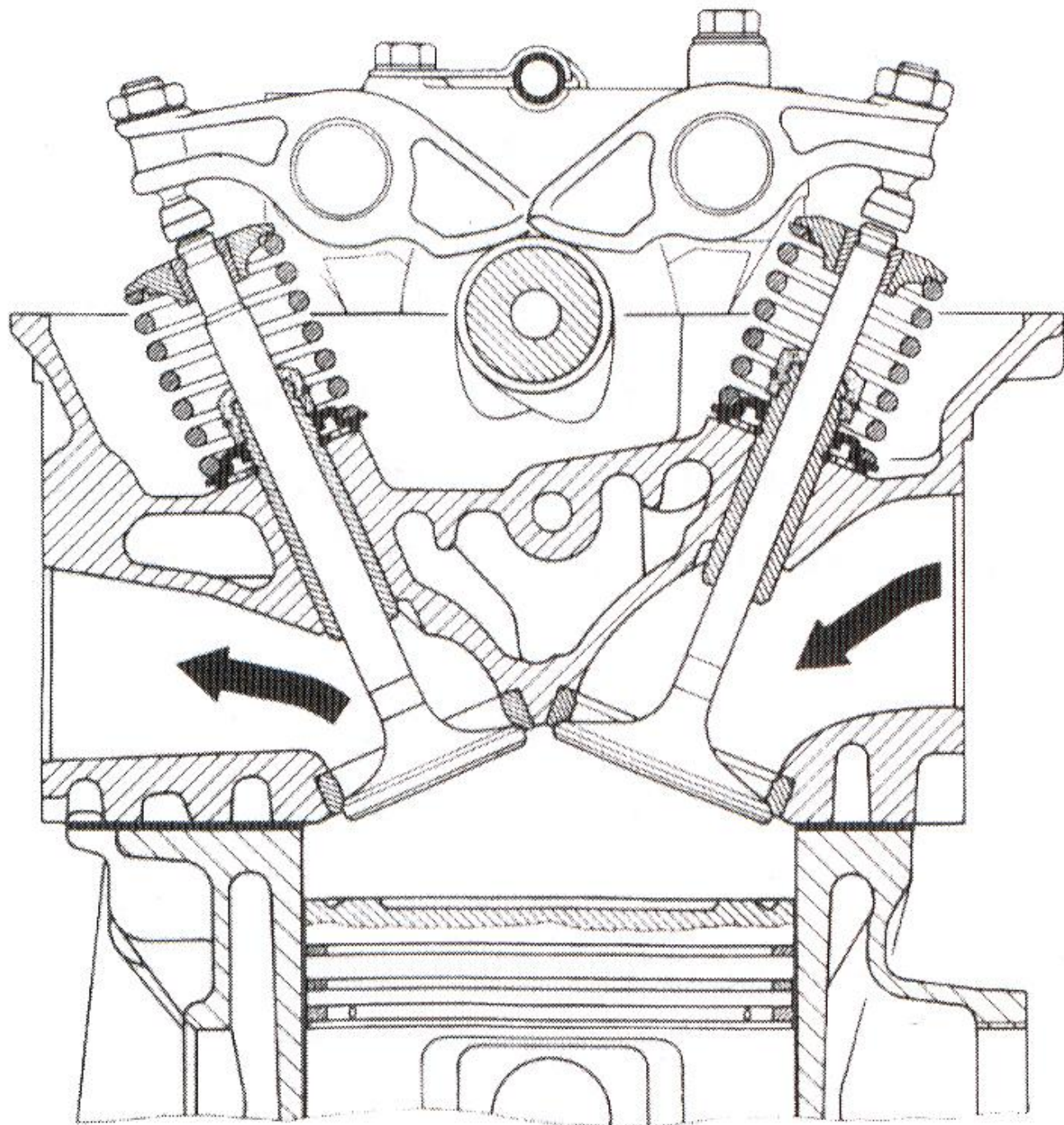

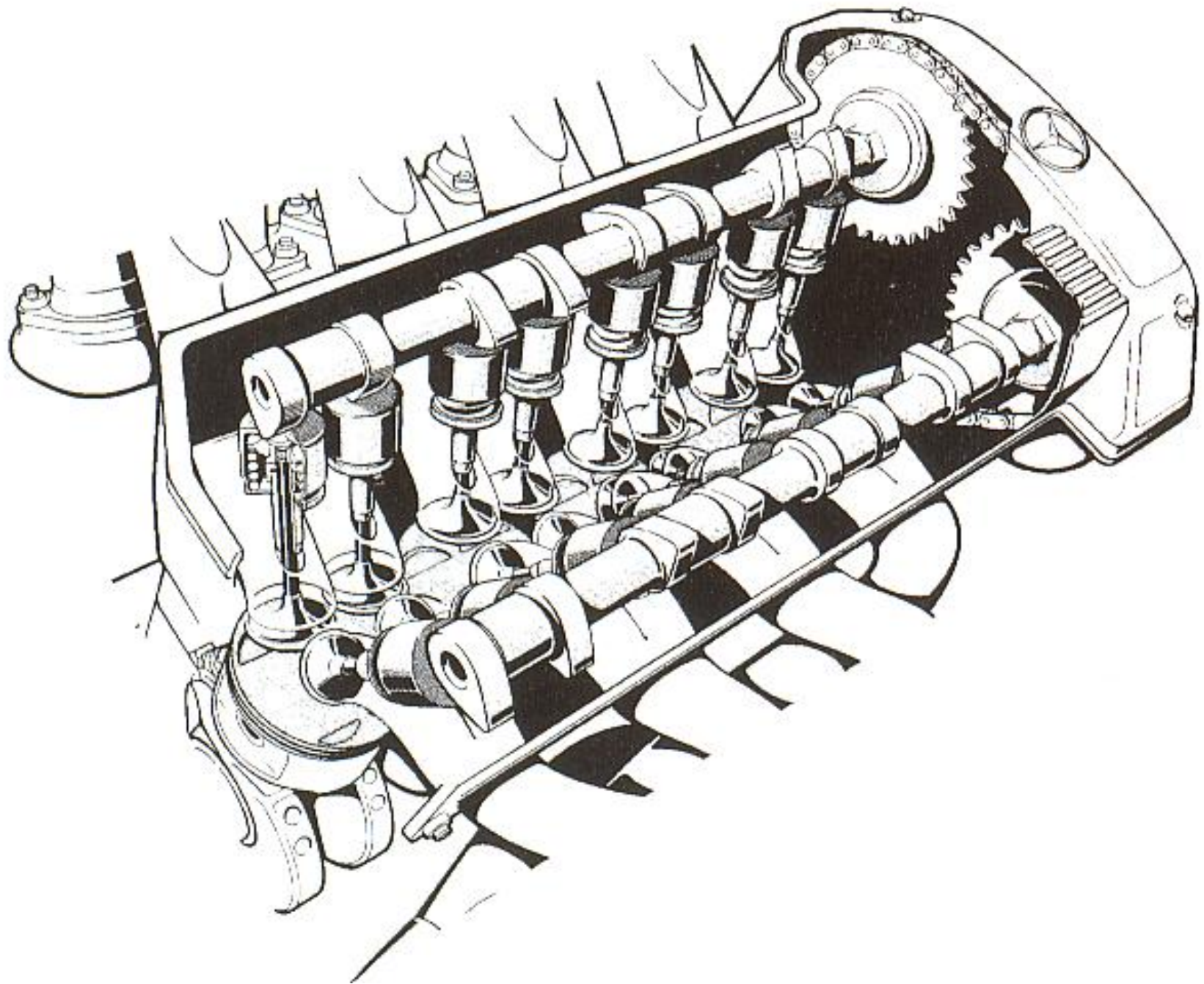

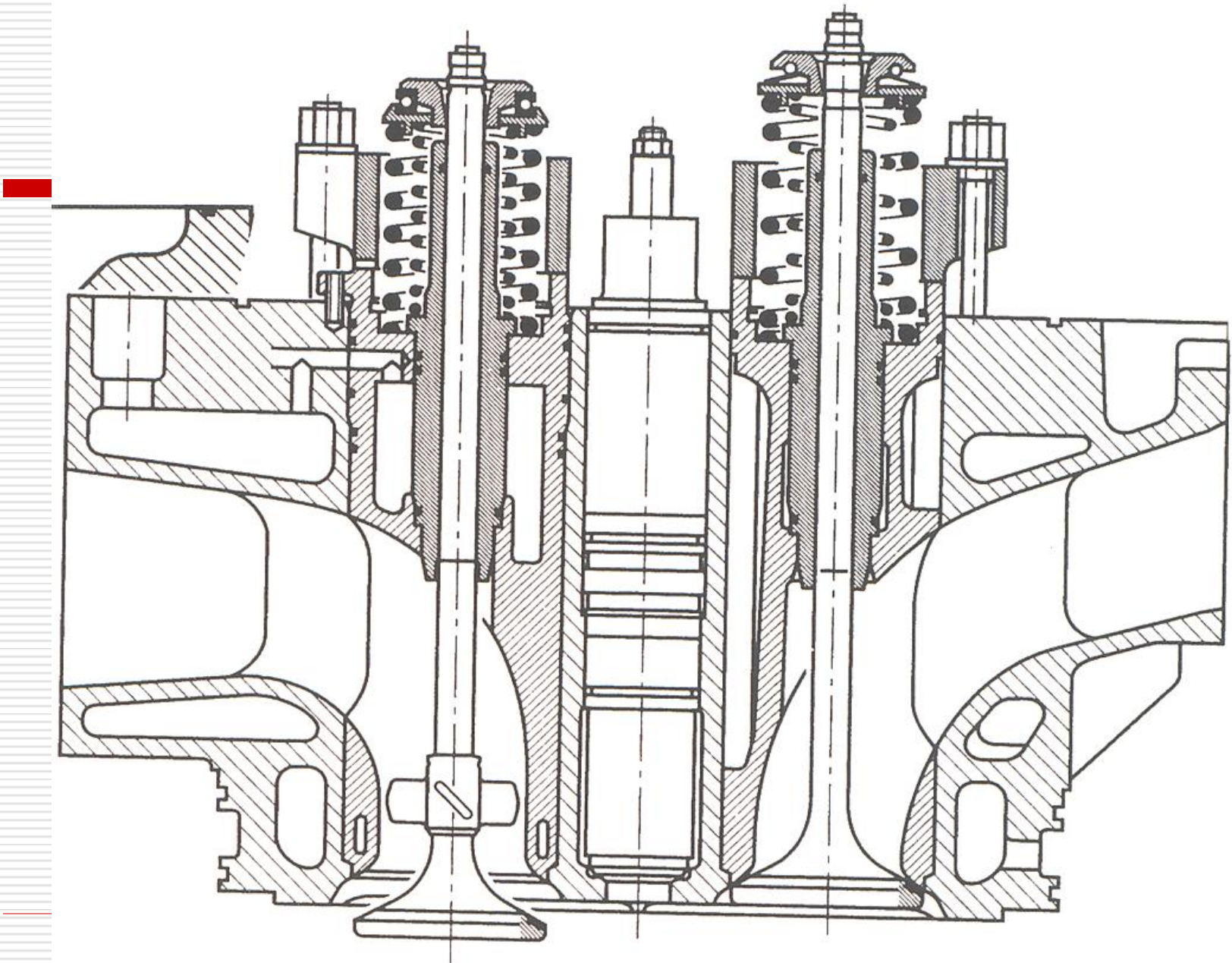

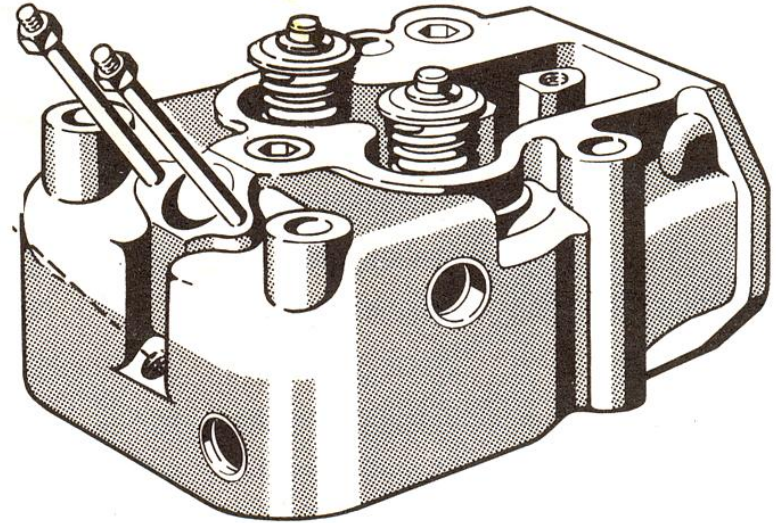
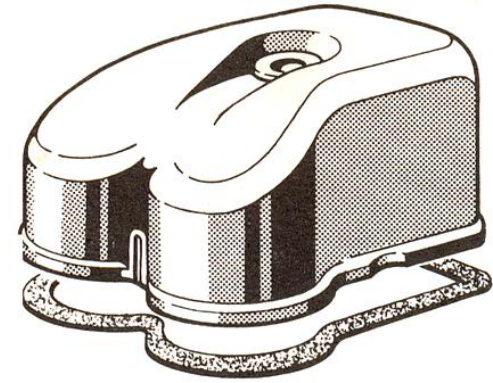
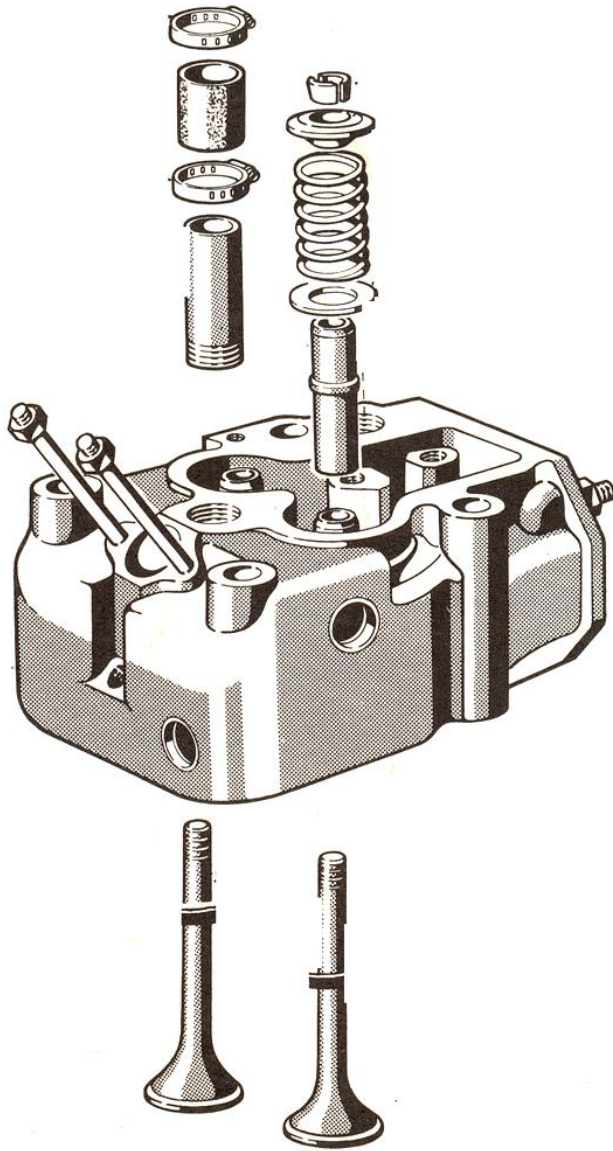

-
- Ventlabil stillt með smurþrýstingi.

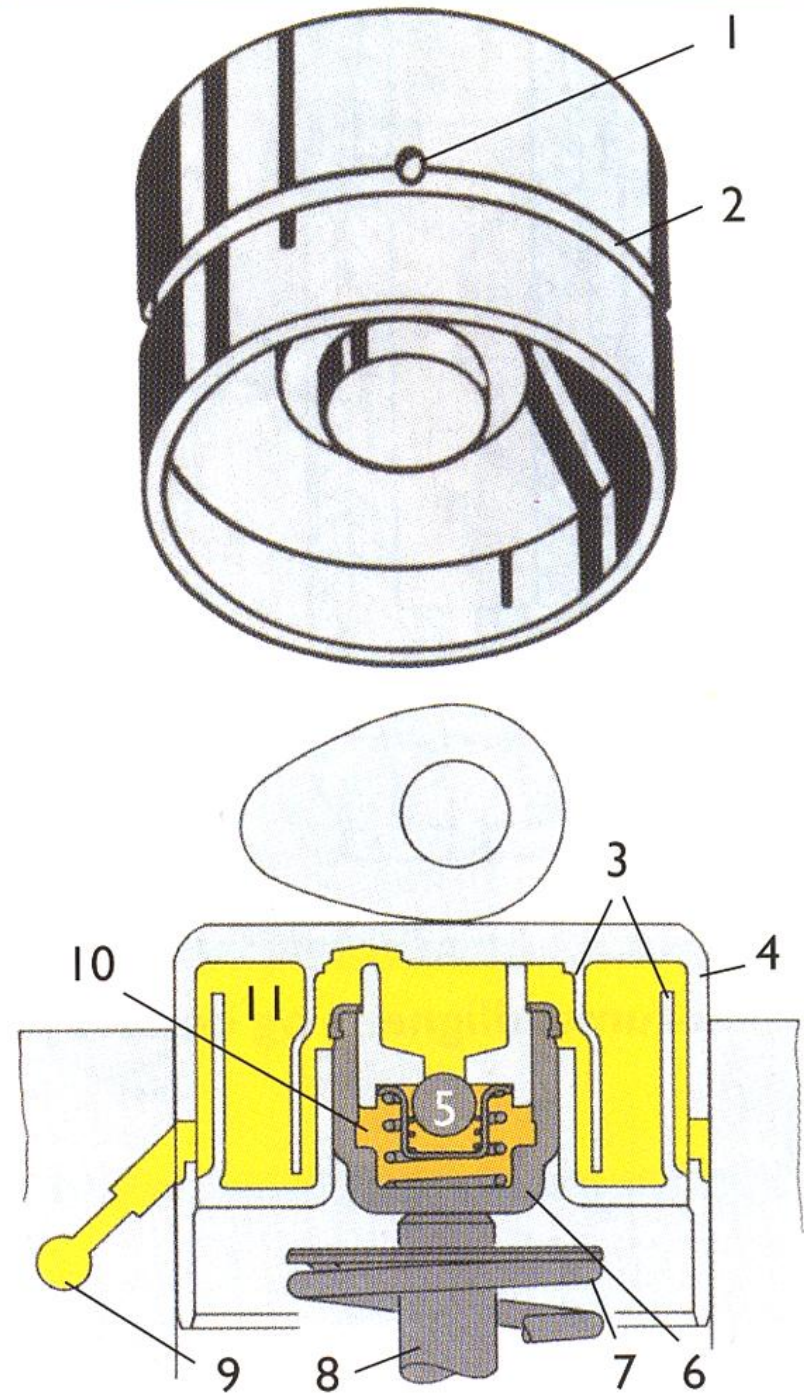

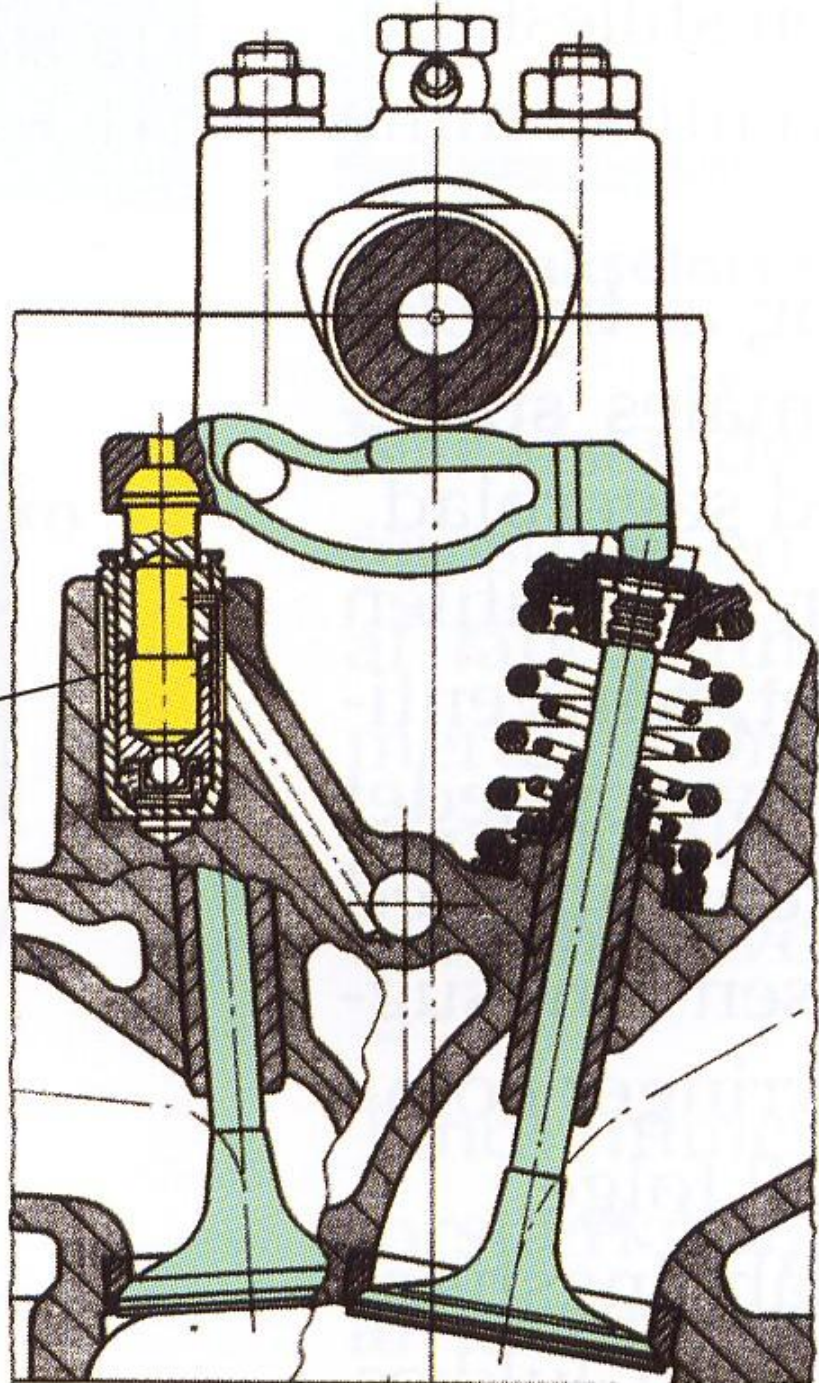
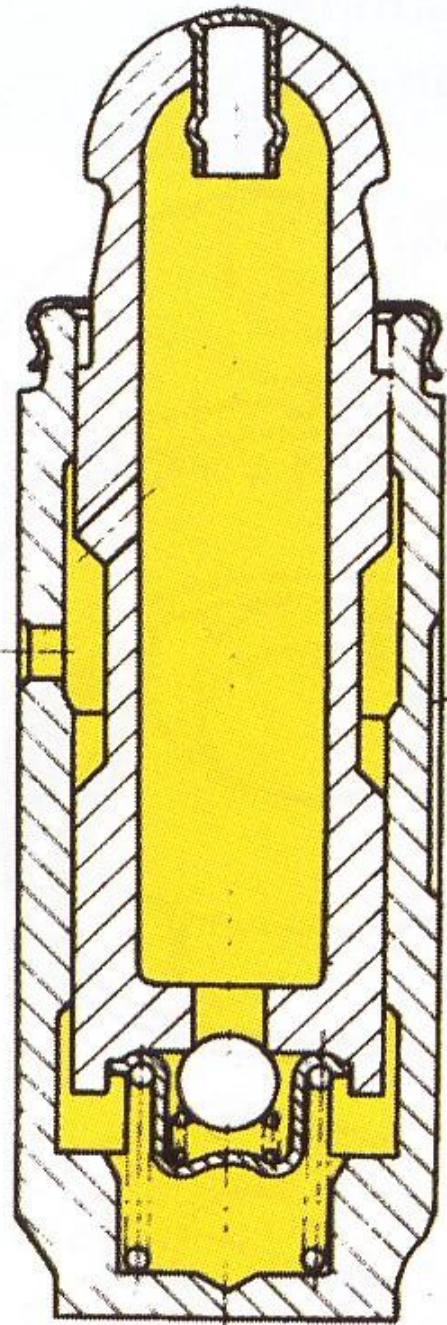

Rotor-caps

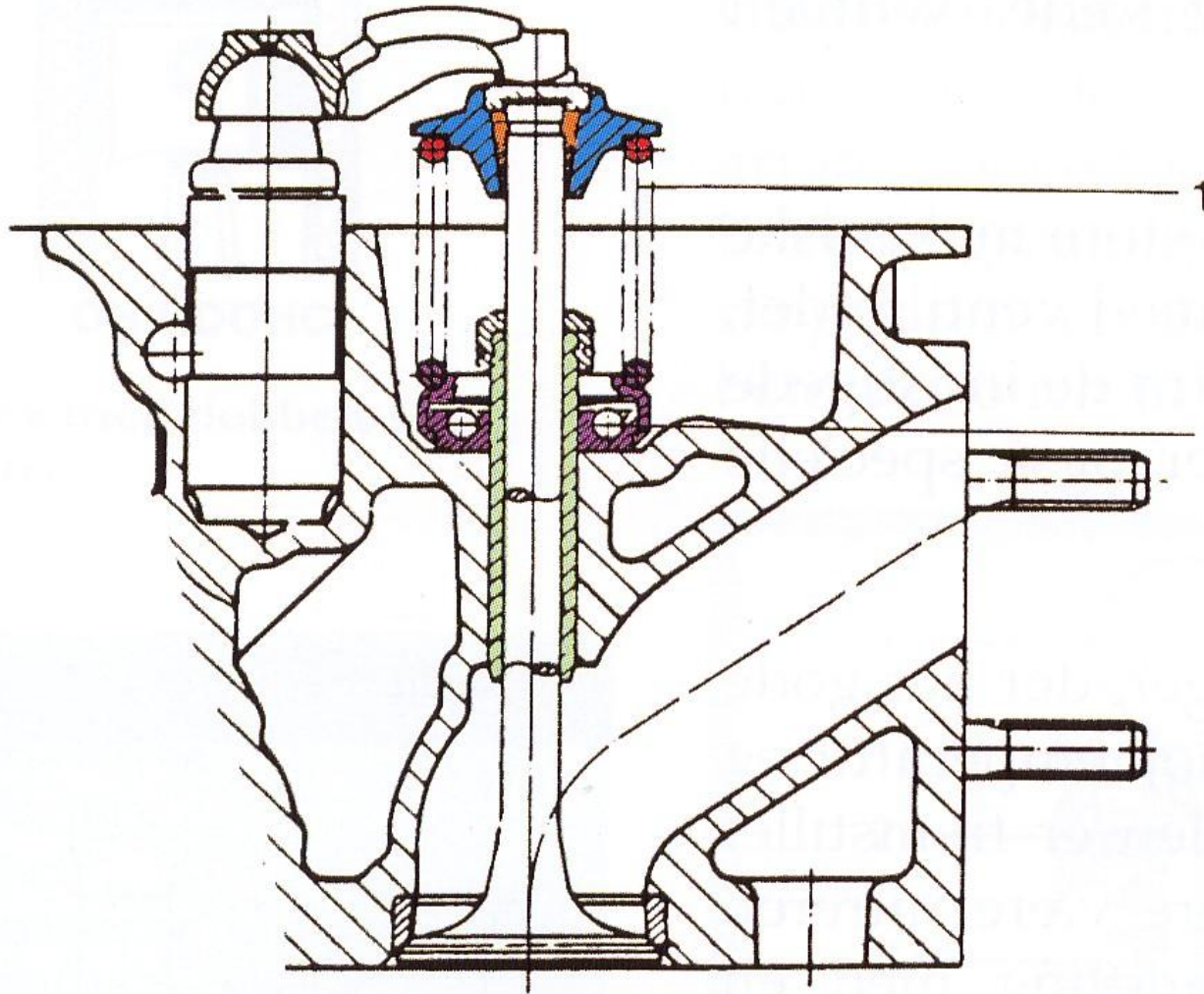

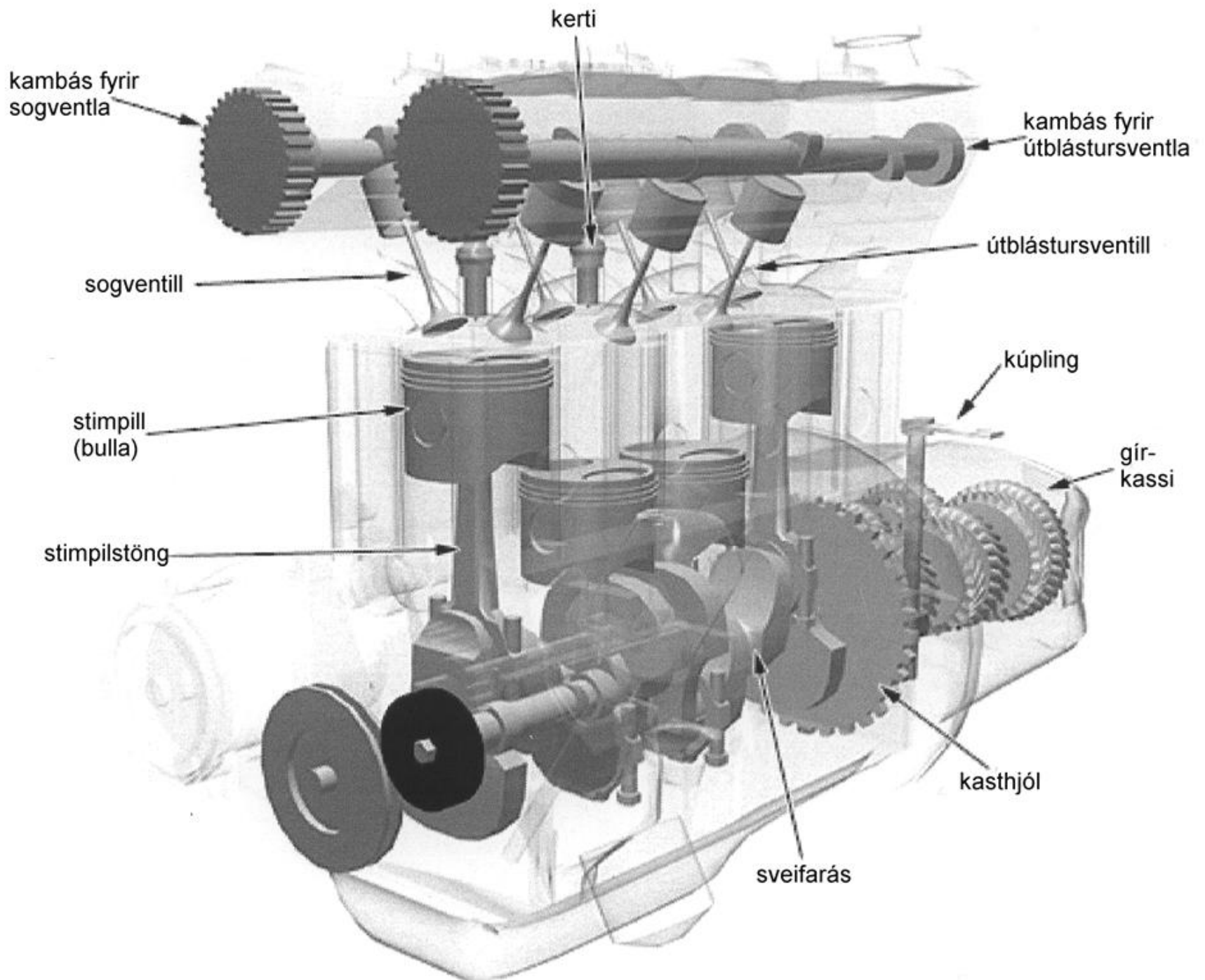

-
- Tannhjól framán á vél
 - Ef lega fer getur komið reykur upp frá sveifarhúsi

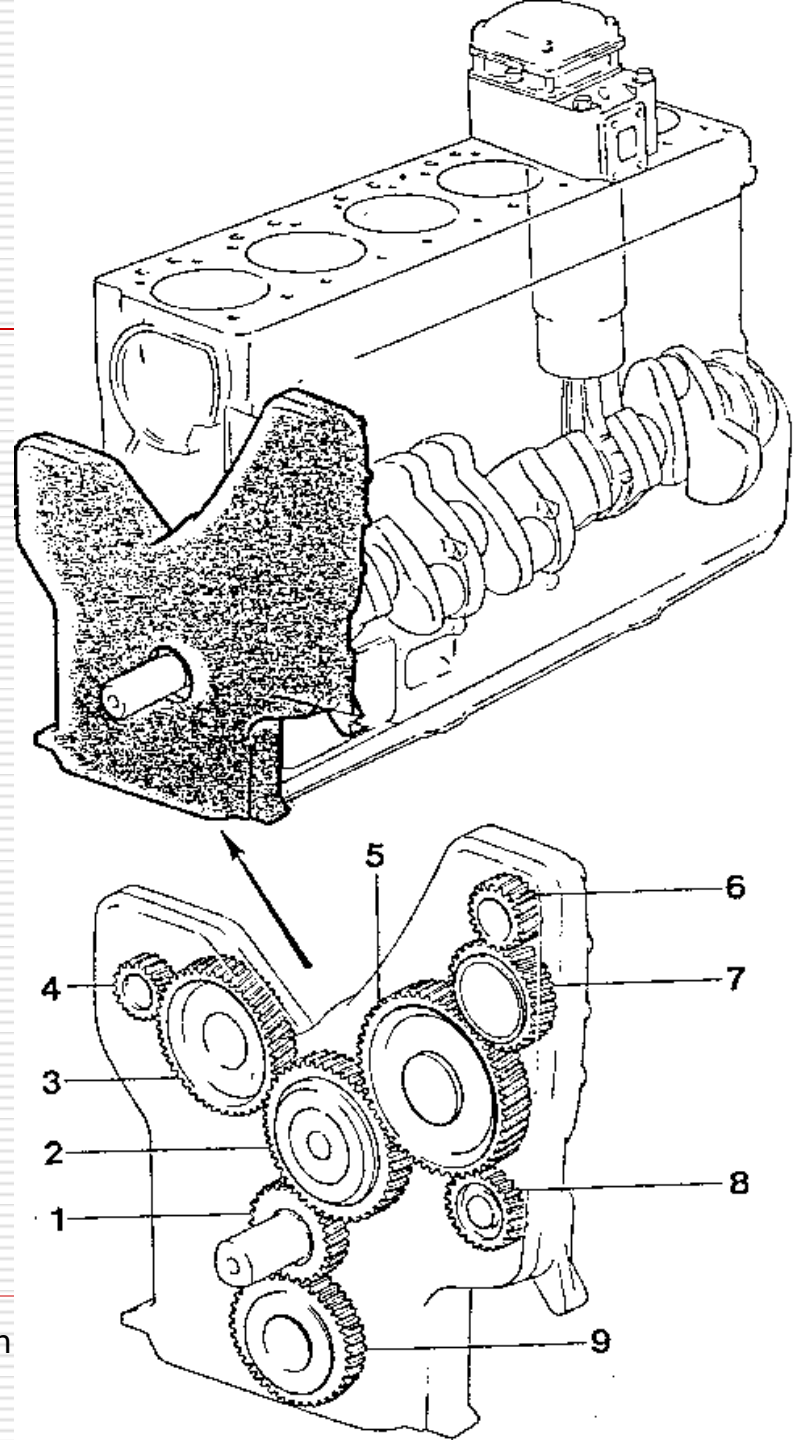

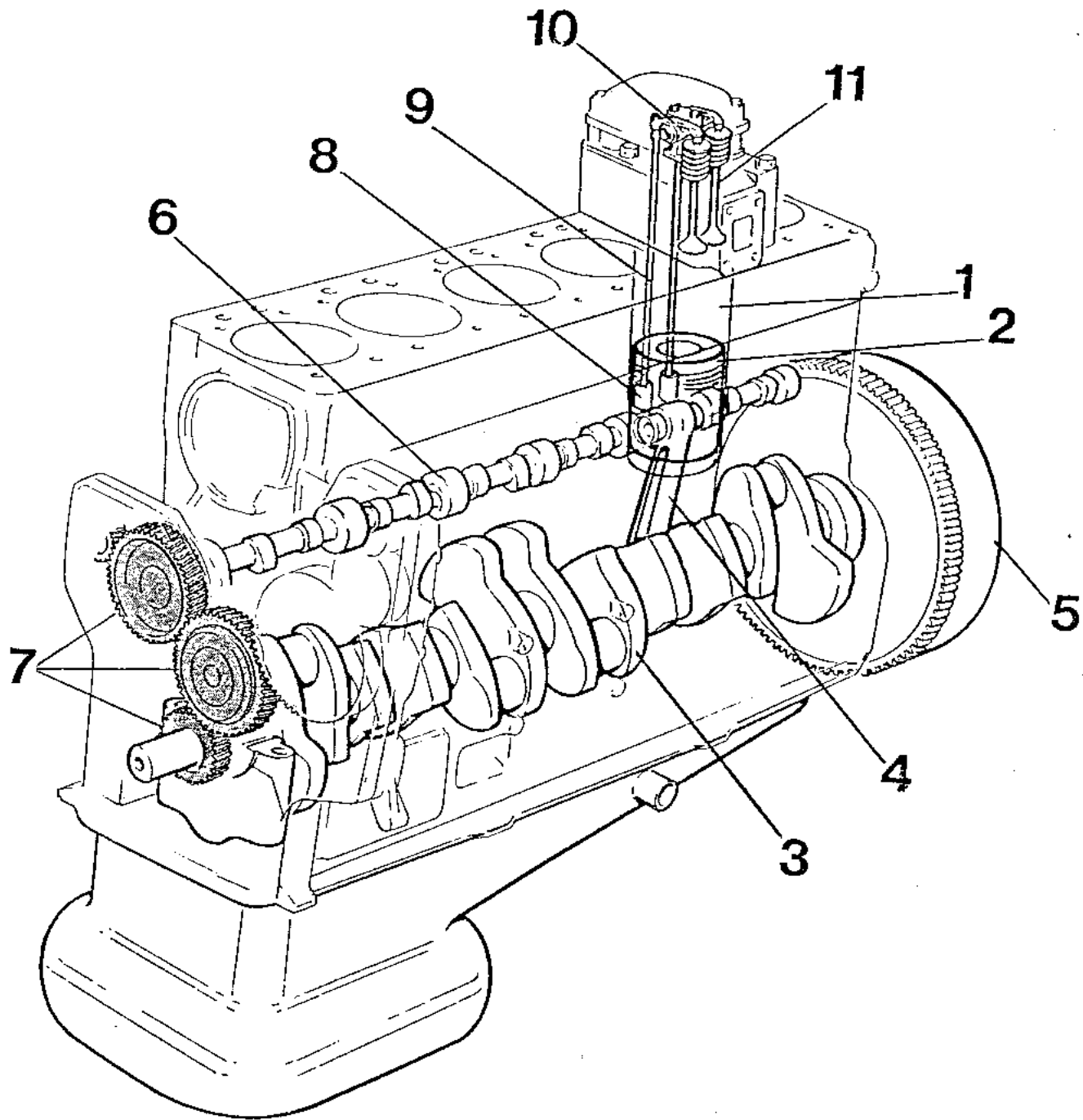

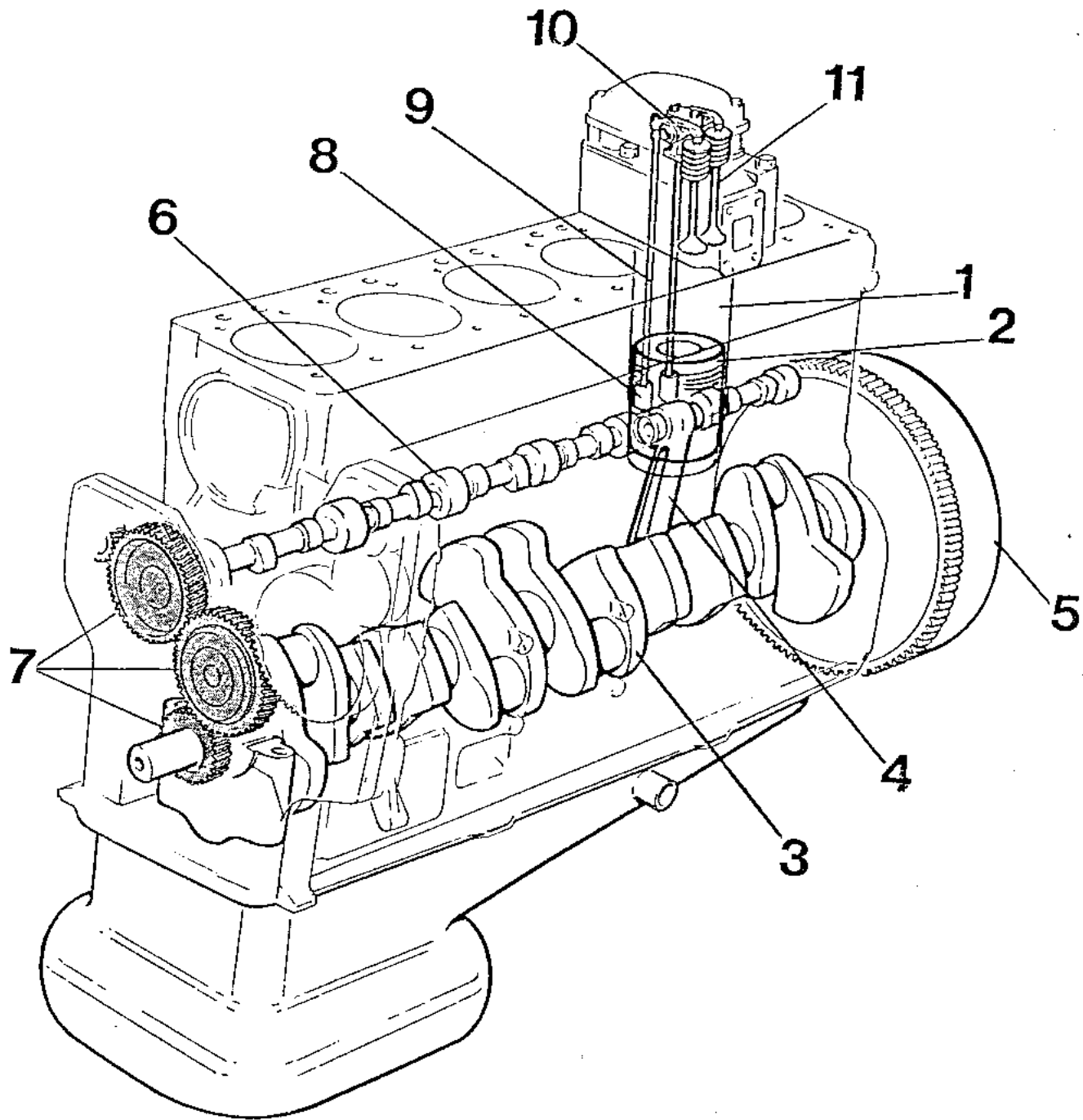

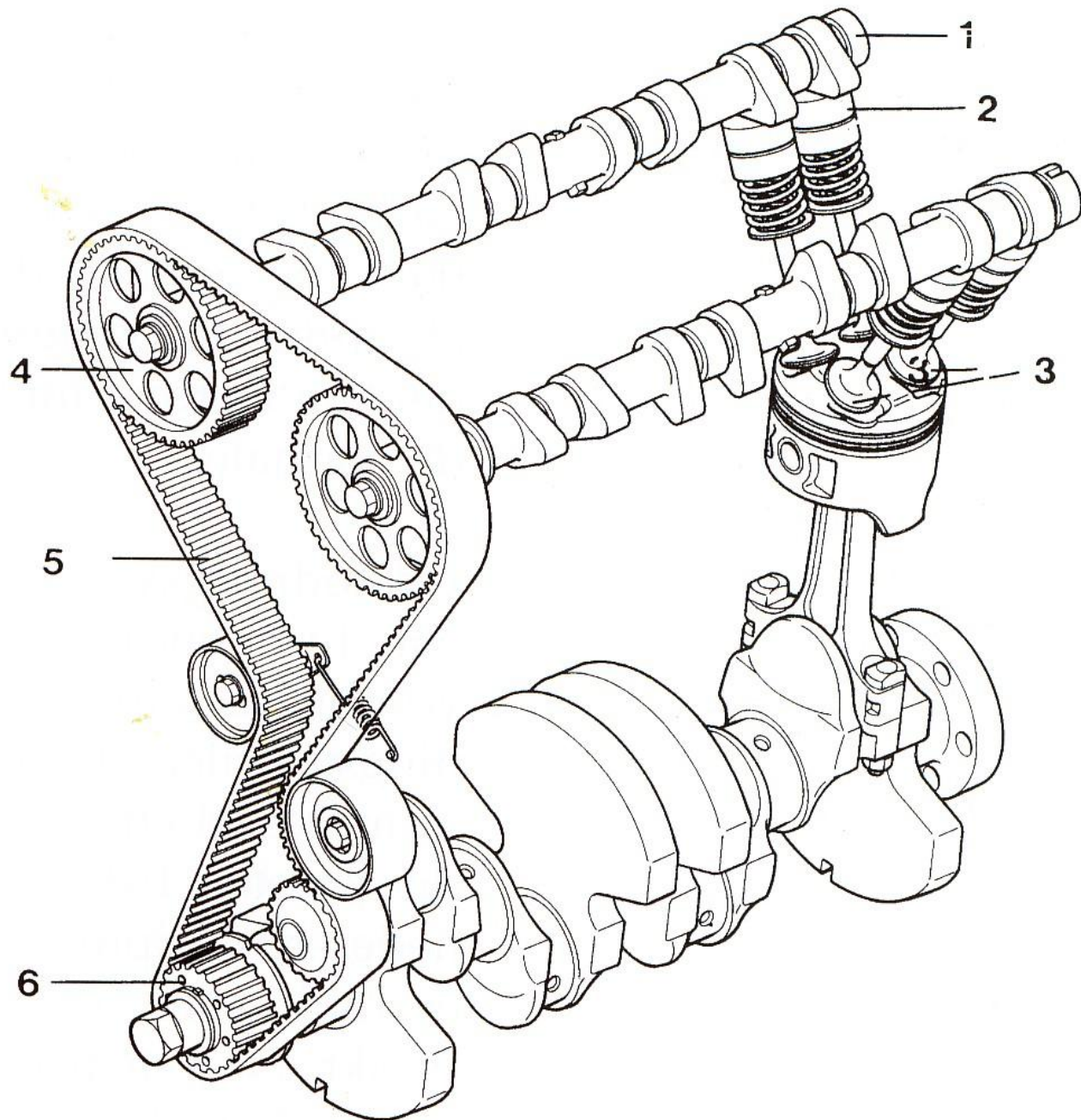

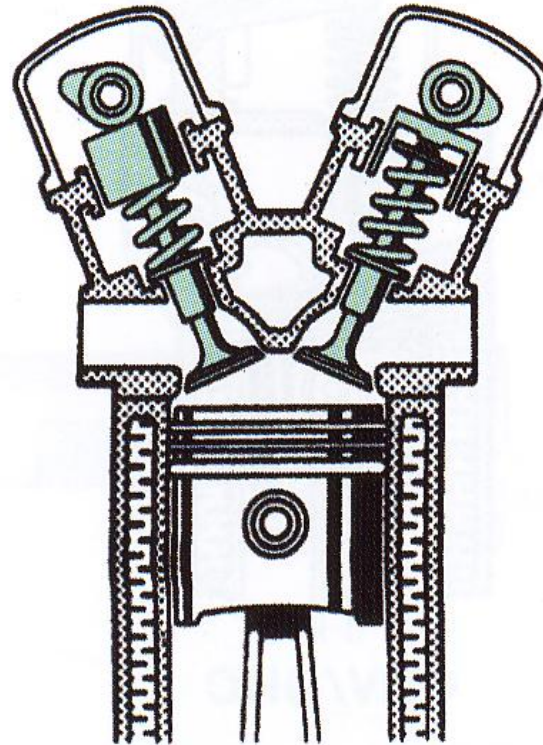
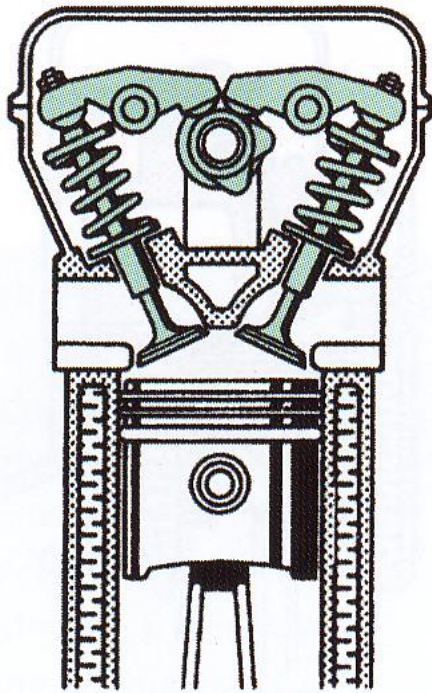

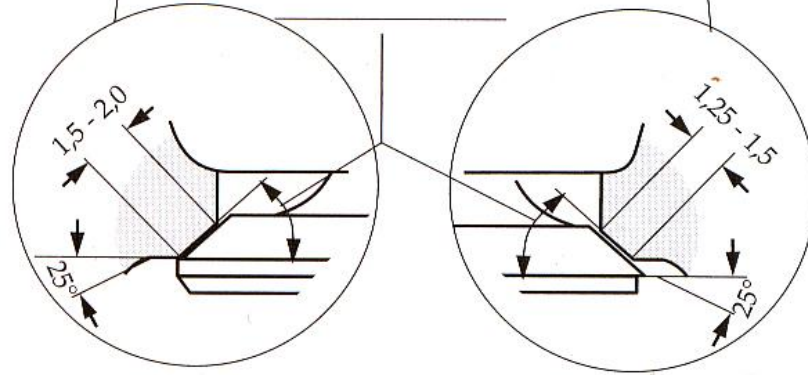
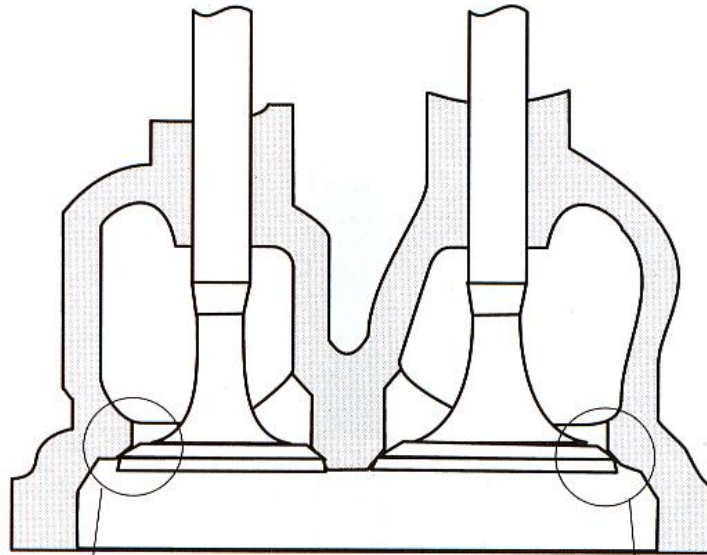

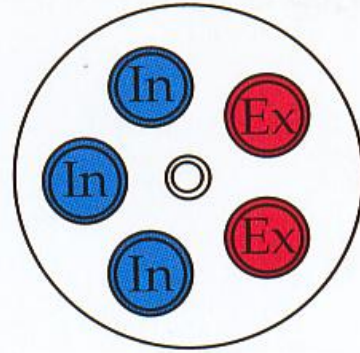
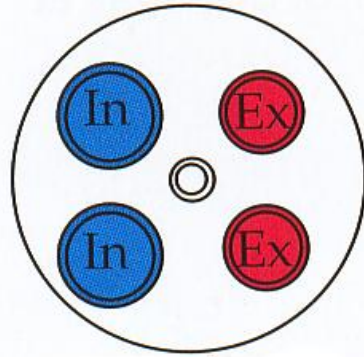
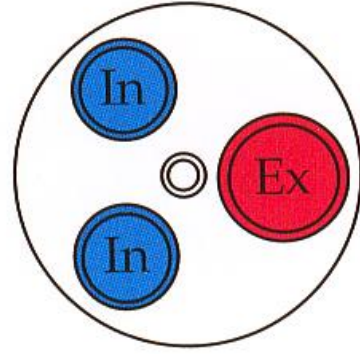
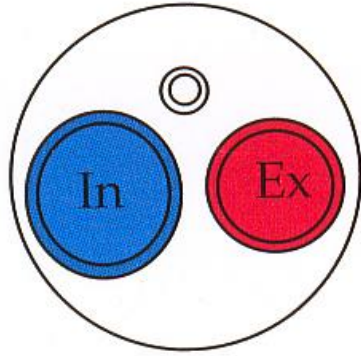

In =

Ex =

Útblástursloki

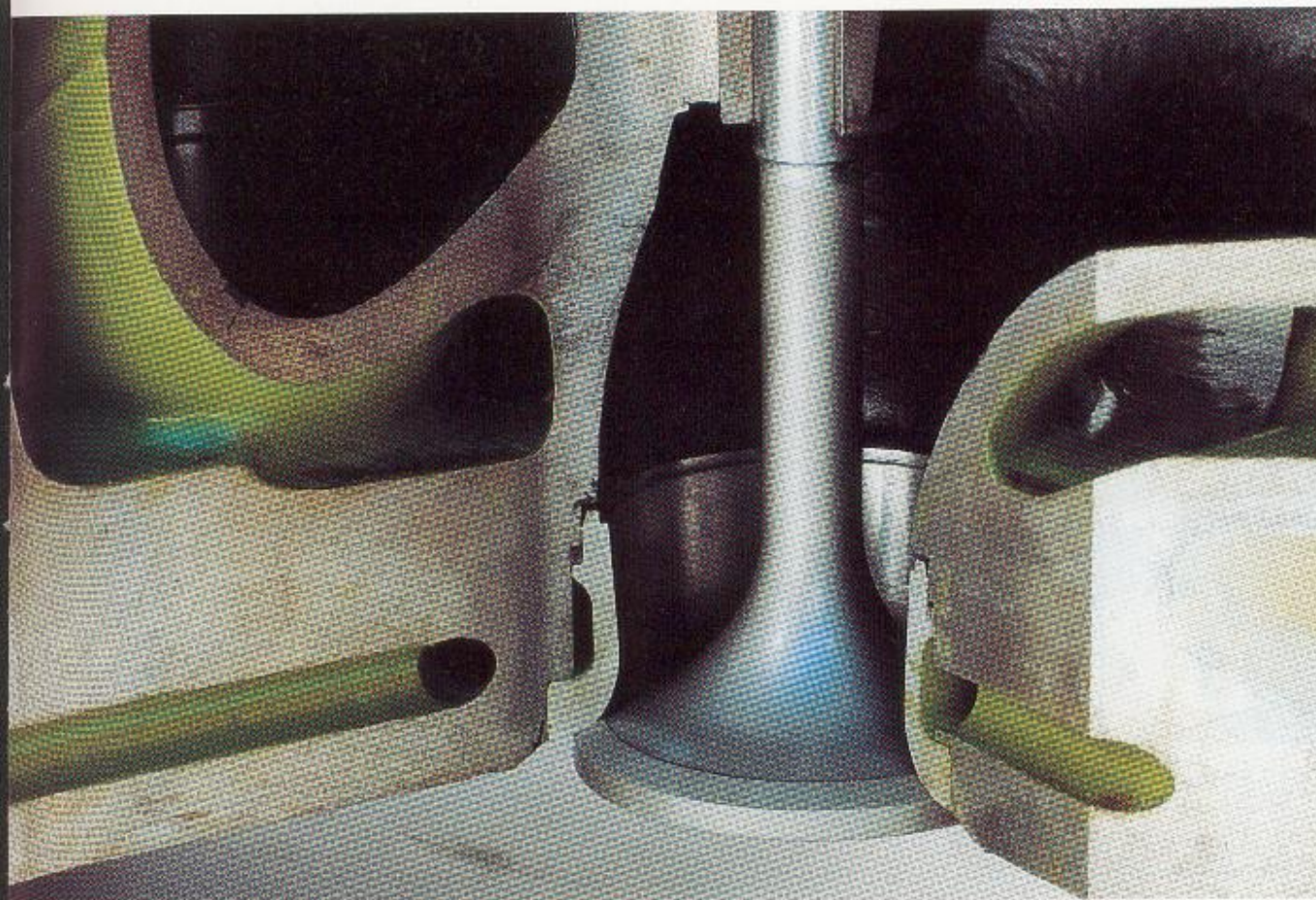

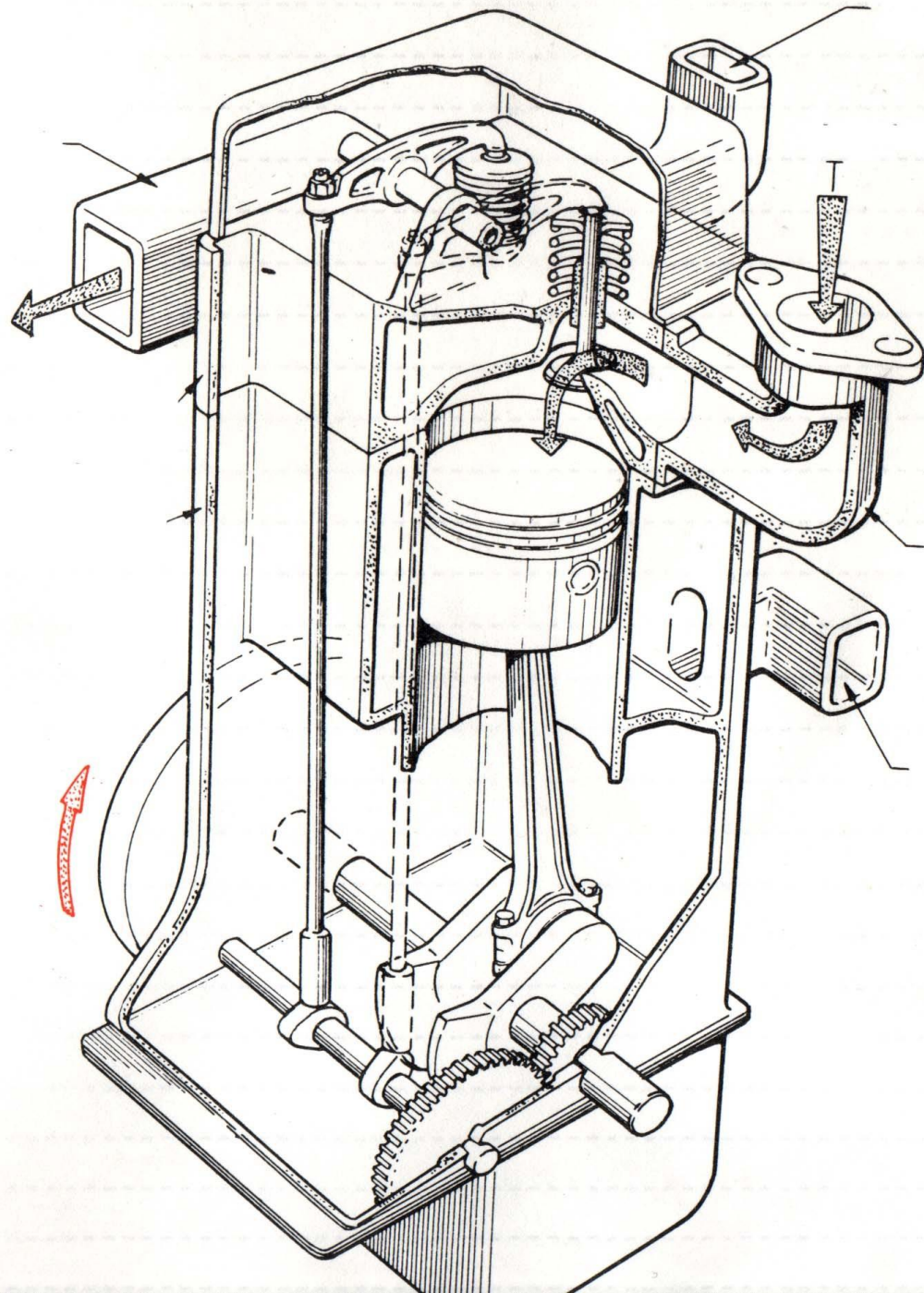

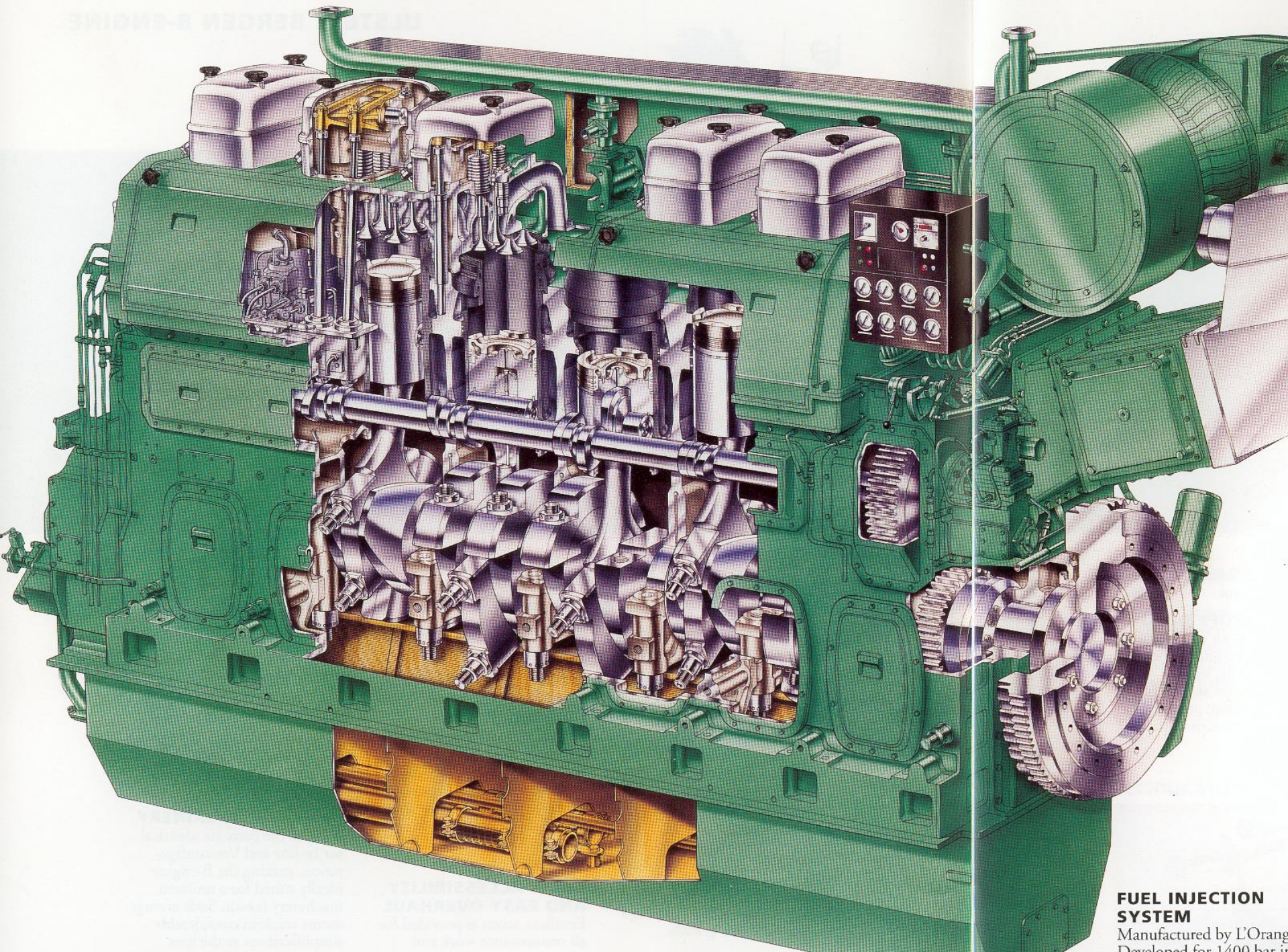

FUEL INJECTION SYSTEM

Manufactured by L'Orang
Developed for 1400 bar

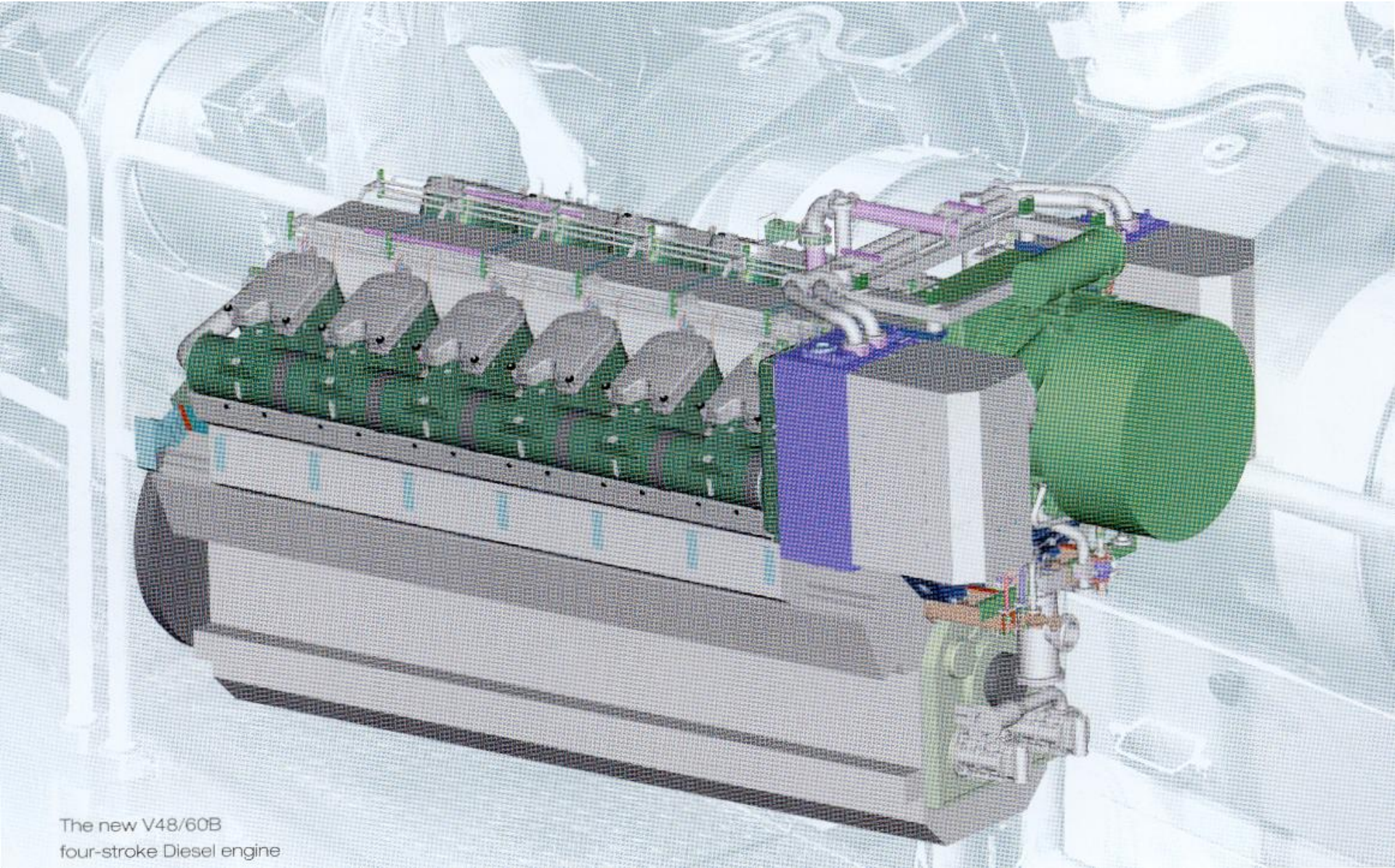

The new V48/60B
four-stroke Diesel engine

L27/38

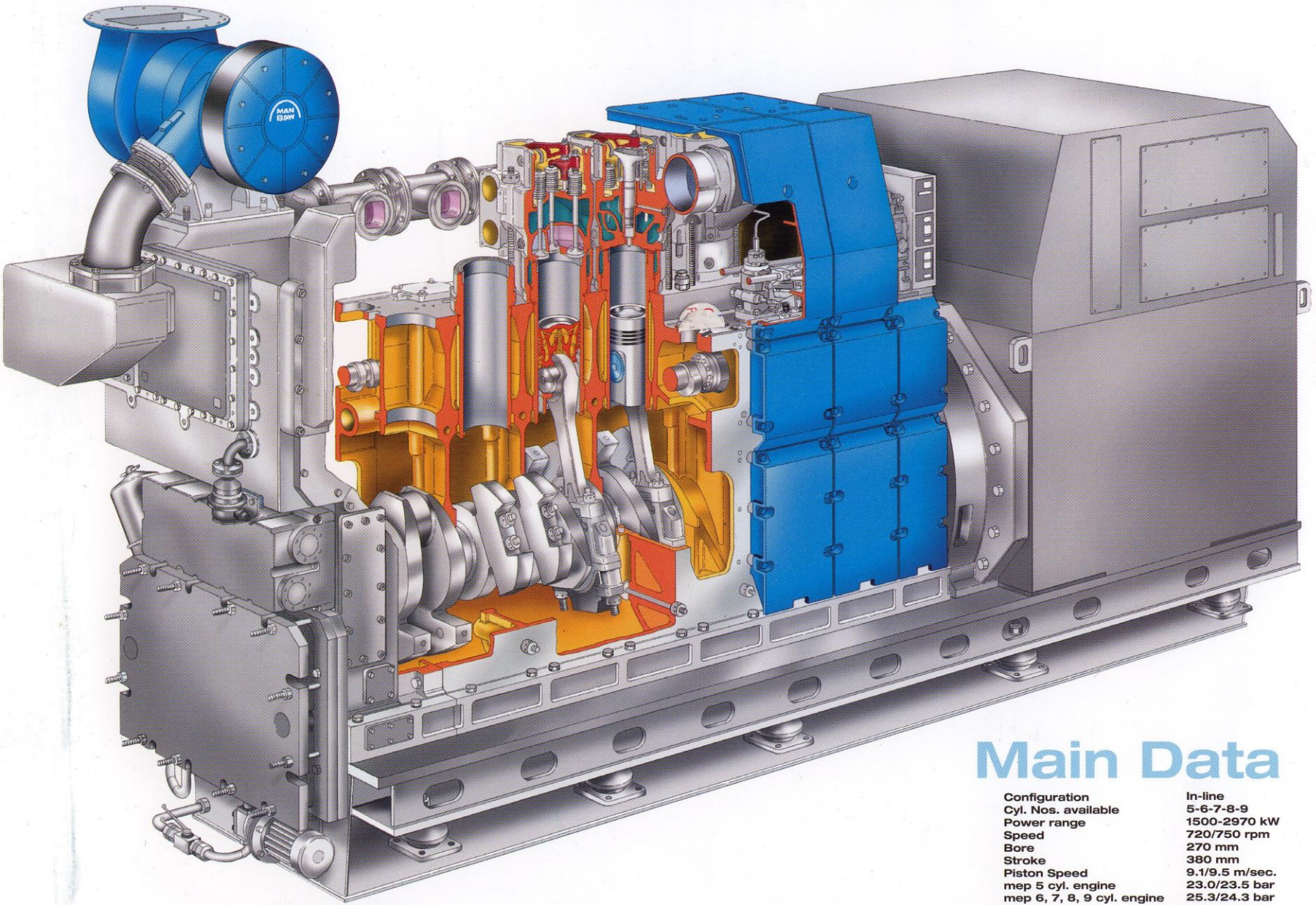

Main Data

Configuration	In-line
Cyl. Nos. available	5-6-7-8-9
Power range	1500-2970 kW
Speed	720/750 rpm
Bore	270 mm
Stroke	380 mm
Piston Speed	9.1/9.5 m/sec.
mep 5 cyl. engine	23.0/23.5 bar
mep 6, 7, 8, 9 cyl. engine	25.3/24.3 bar

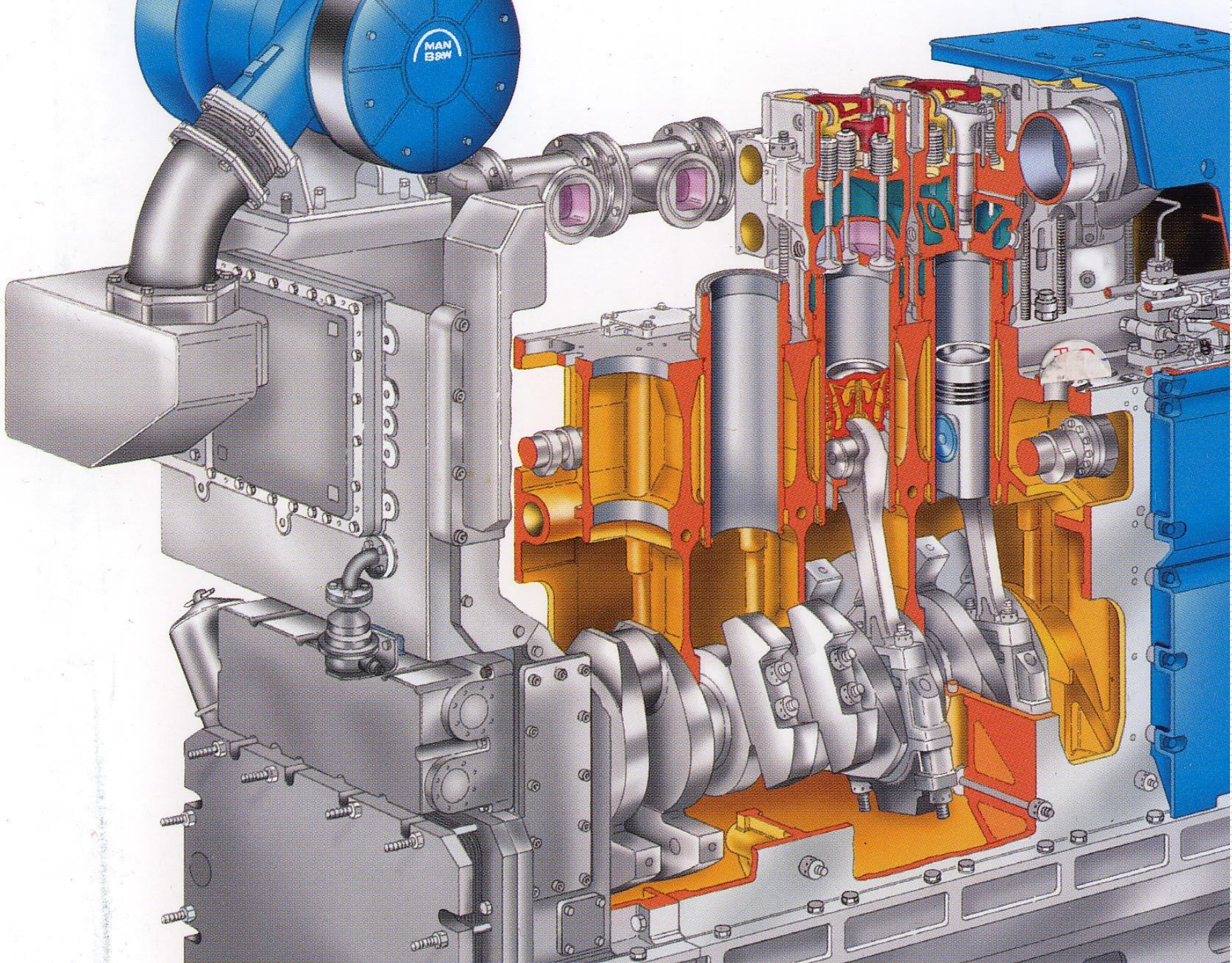

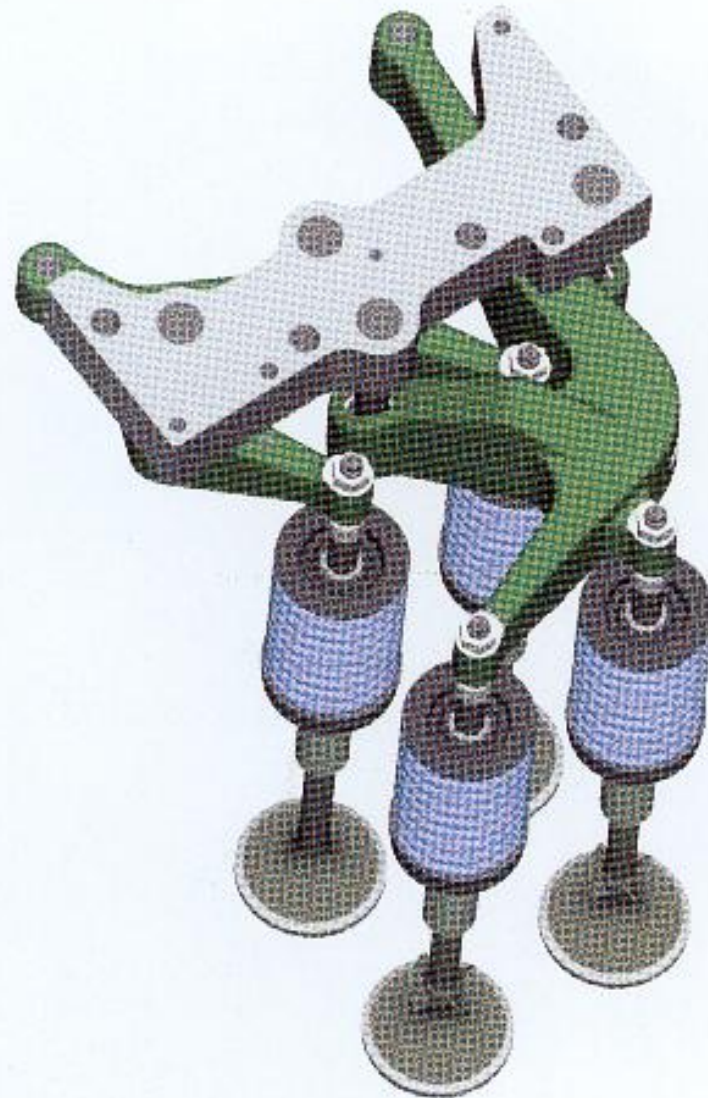

48/60B valve gear

U
P
ir
n
T
.
.
.
.
.
.
.
.
.
.
A
C
E

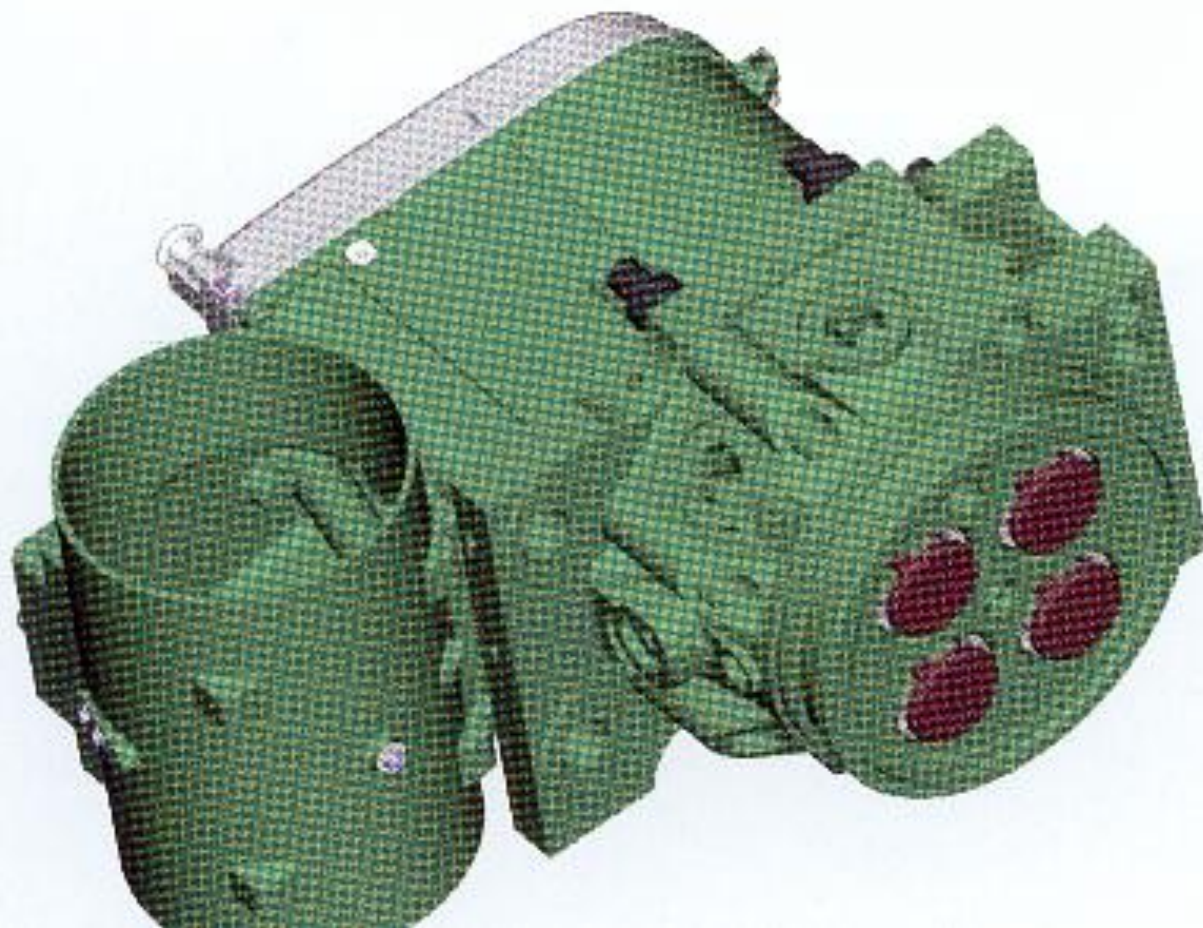

New 48/60

Guðmundur Einarsson

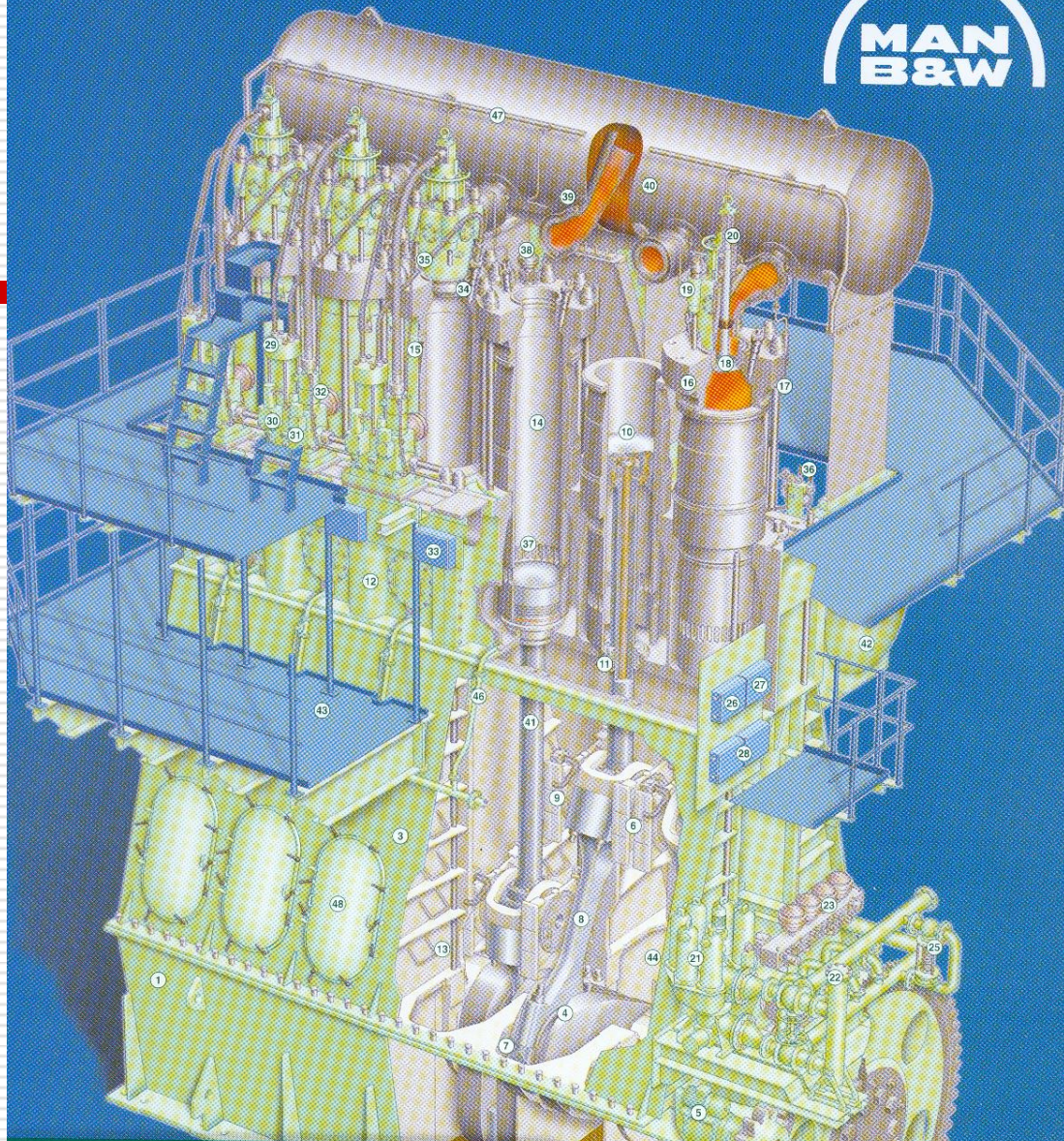

KEY TO COMPONENTS

- | | | |
|----------------------------|----------------------------------|-----------------------------------|
| 1 Bedplate | 18 Exhaust valve spindle | 33 Cylinder Control Unit (CCU) |
| 2 Holding down bolts | 19 Exhaust valve housing | 34 Fuel valve |
| 3 Frame box | 20 Pneumatic closing | 35 Fuel oil high-pressure pipes |
| 4 Crankshaft | 21 "air spring" chamber | 36 MAN B&W Alpha lubricator unit |
| 5 Turning gear | 22 Main filter | 37 Scavenge air ports |
| 6 Crosshead guide shoe | 23 Redundancy filter | 38 Starting air valve |
| 7 Crankpin bearing cap | 24 Safety and accumulator block | 39 Exhaust gas outlet/compensator |
| 8 Connecting rod | 25 Turning wheel | 40 Exhaust gas receiver |
| 9 Crosshead | 26 By-pass valve | 41 Piston rod |
| 10 Piston | 27 Engine Control Unit (ECU) | 42 Scavenge air receiver |
| 11 Piston rod stuffing box | 28 Alpha lubricator control unit | 43 Gallery |



Eldsneytiskerfið

- 1. Að geyma olíuna um borð í skipinu
 - 2. Flytja olíuna til aðal- og hjálparbéla
 - 3. Hreinsa úr olíunni vatn og óhreinindi
- sem í því getur verið

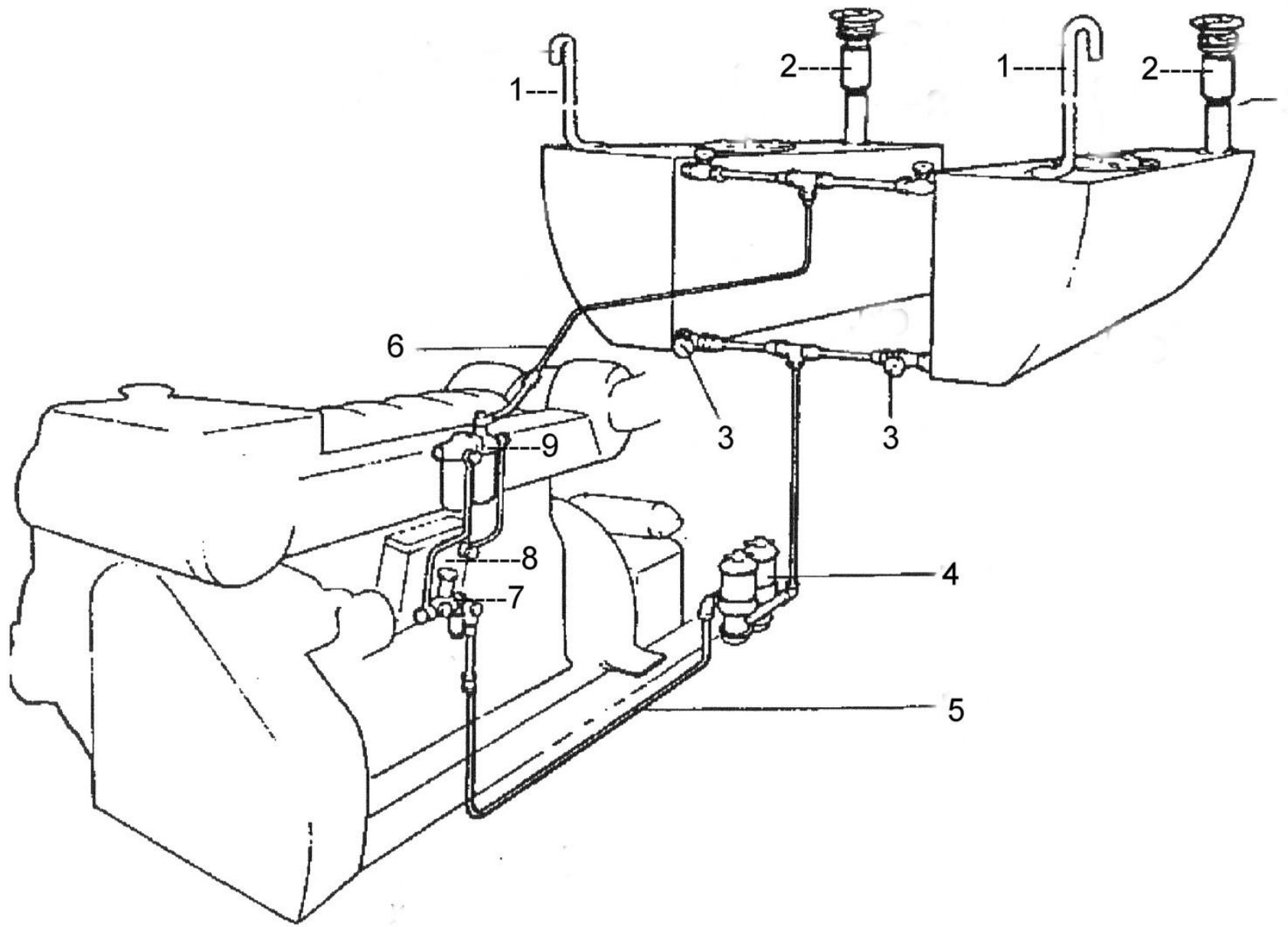

Innsþýting olíu

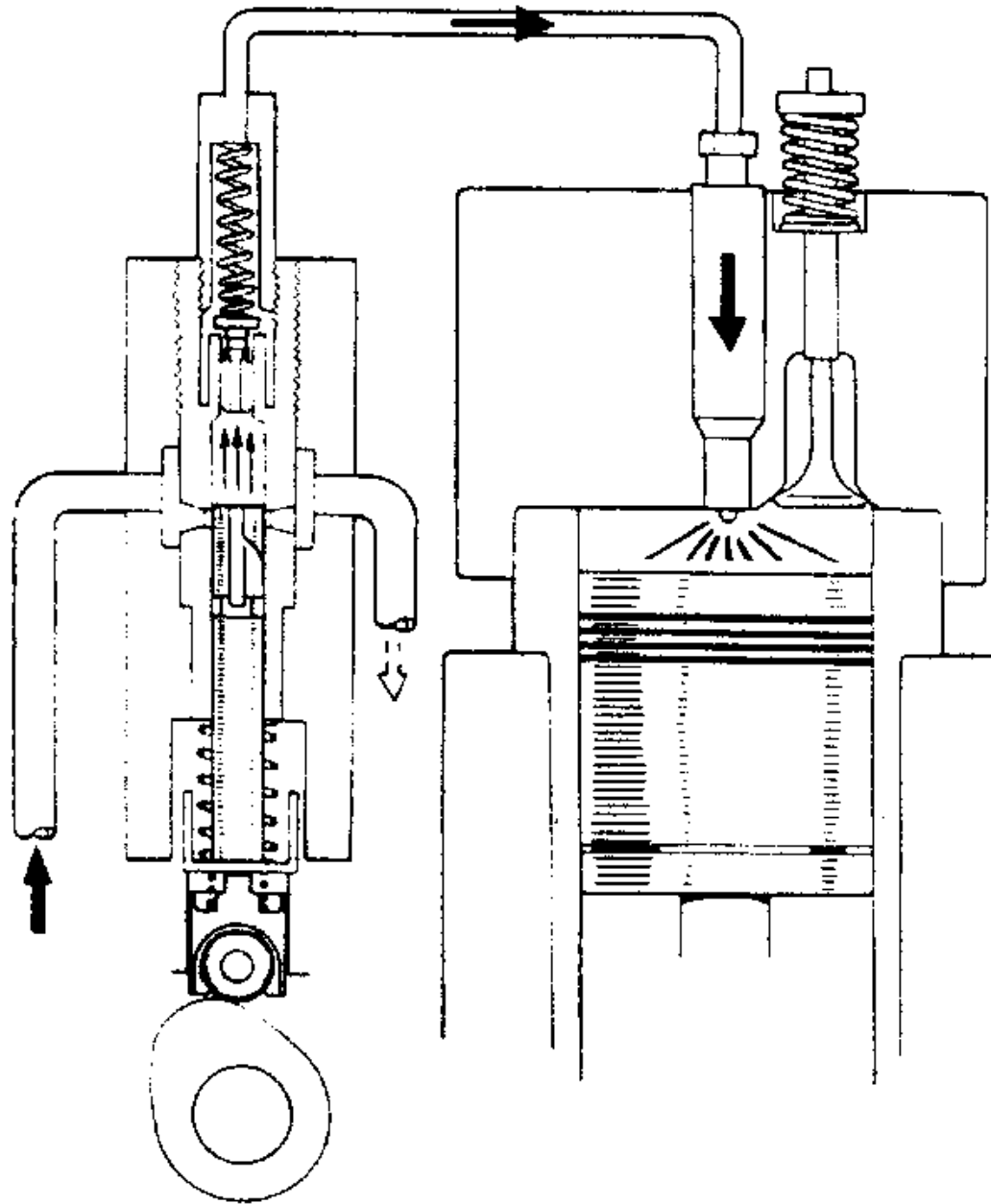

Dælu-unit

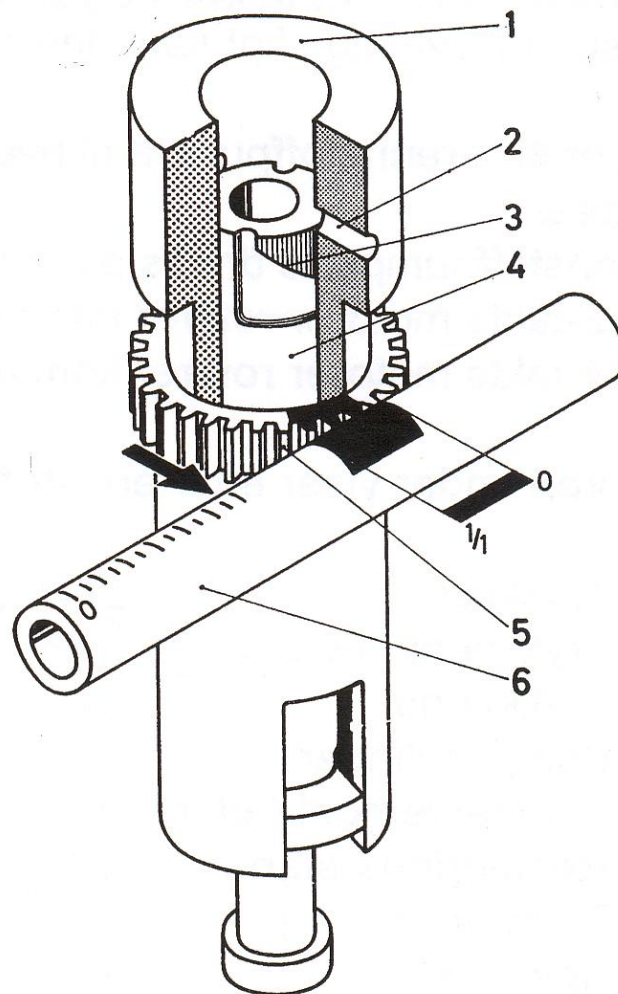

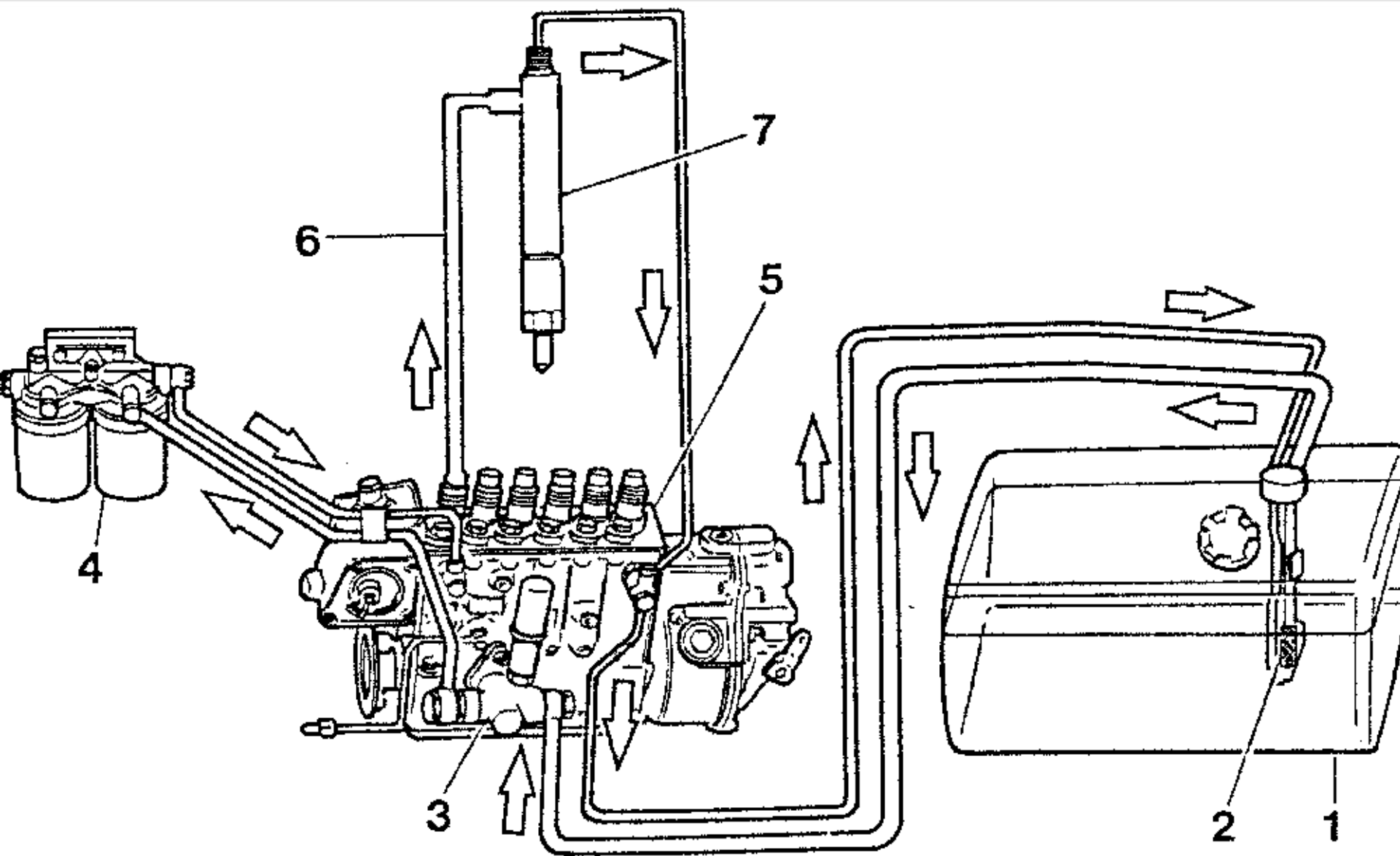

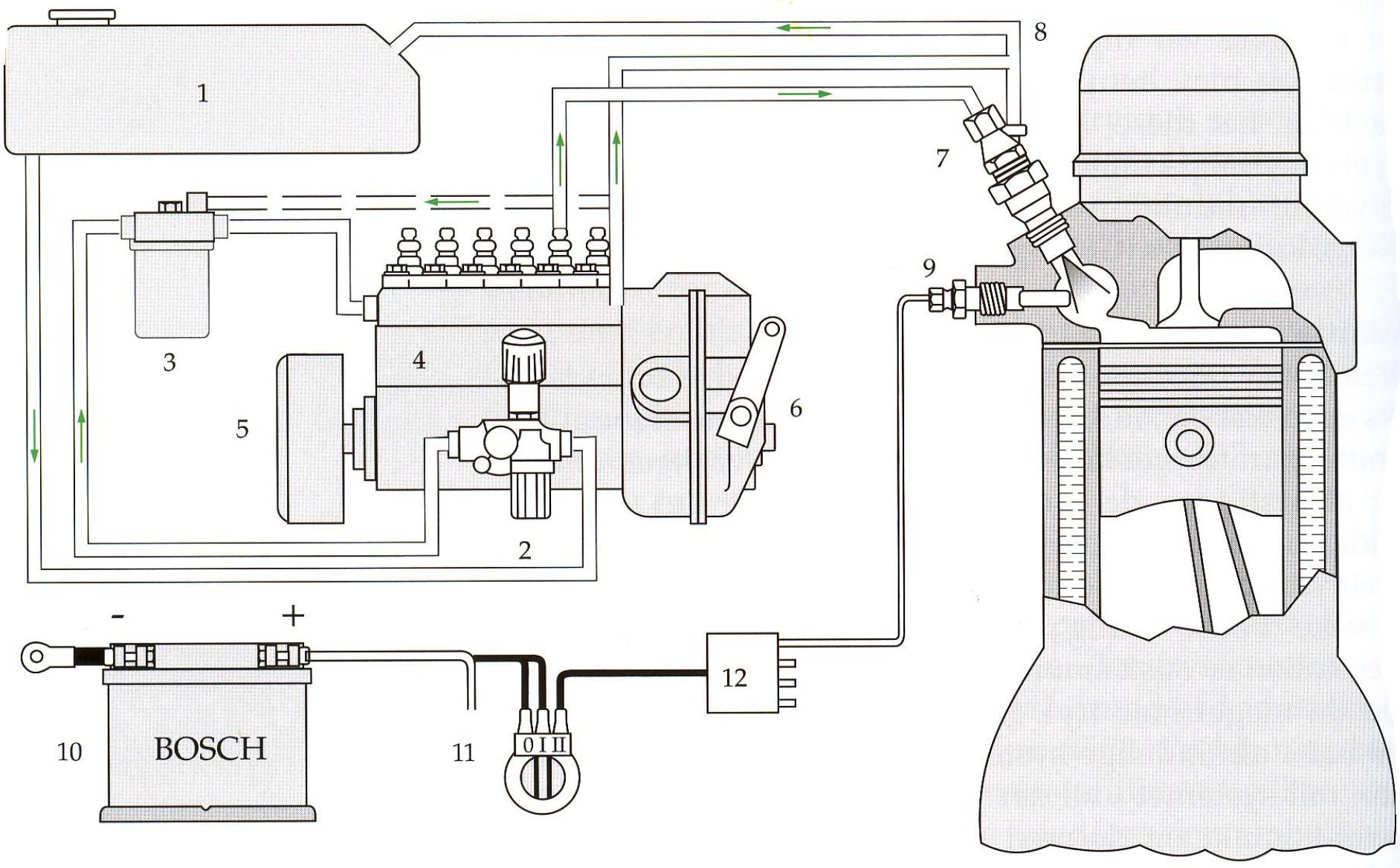

Guðmundur Einarsson

Rađolíuverk

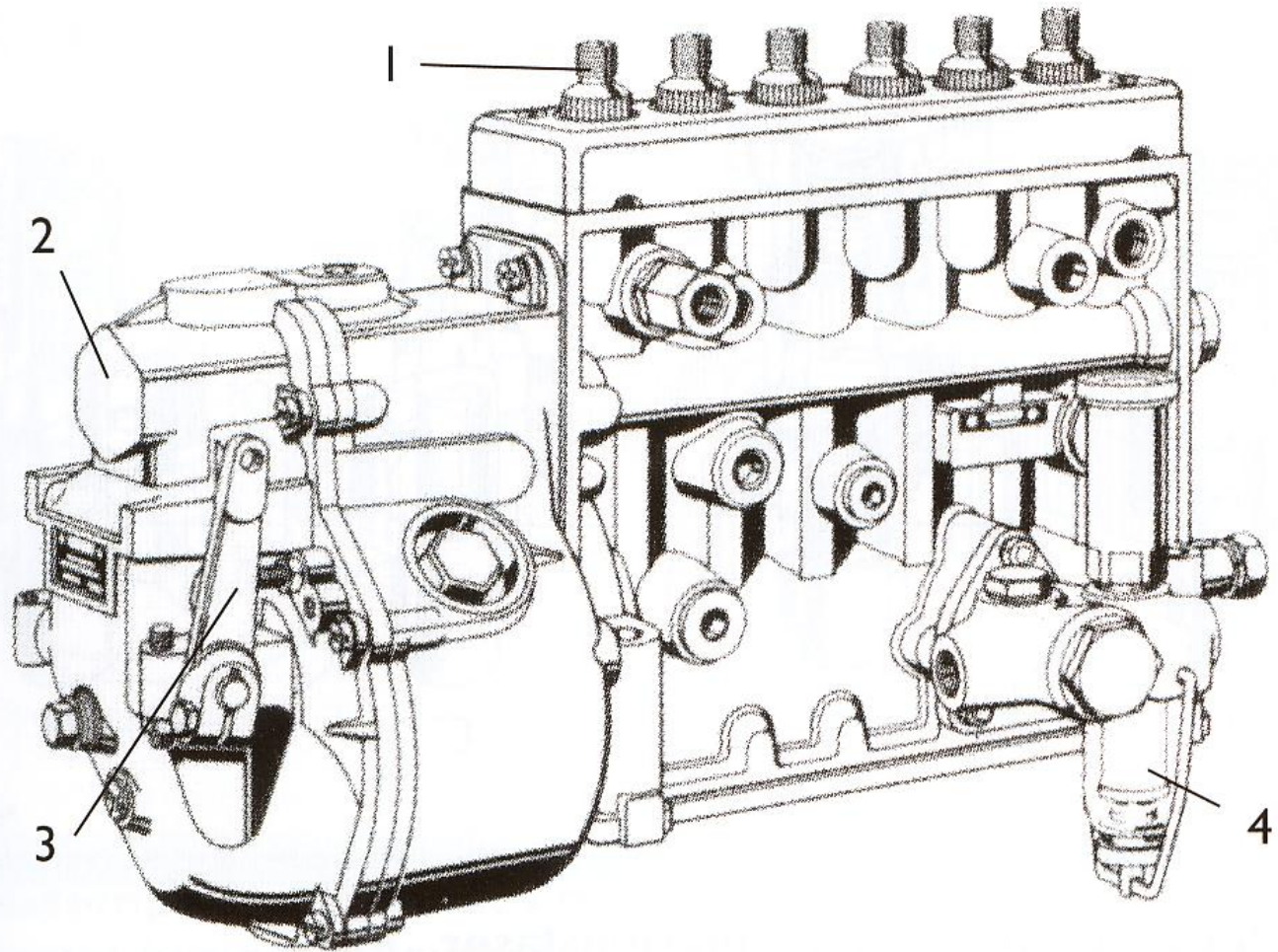

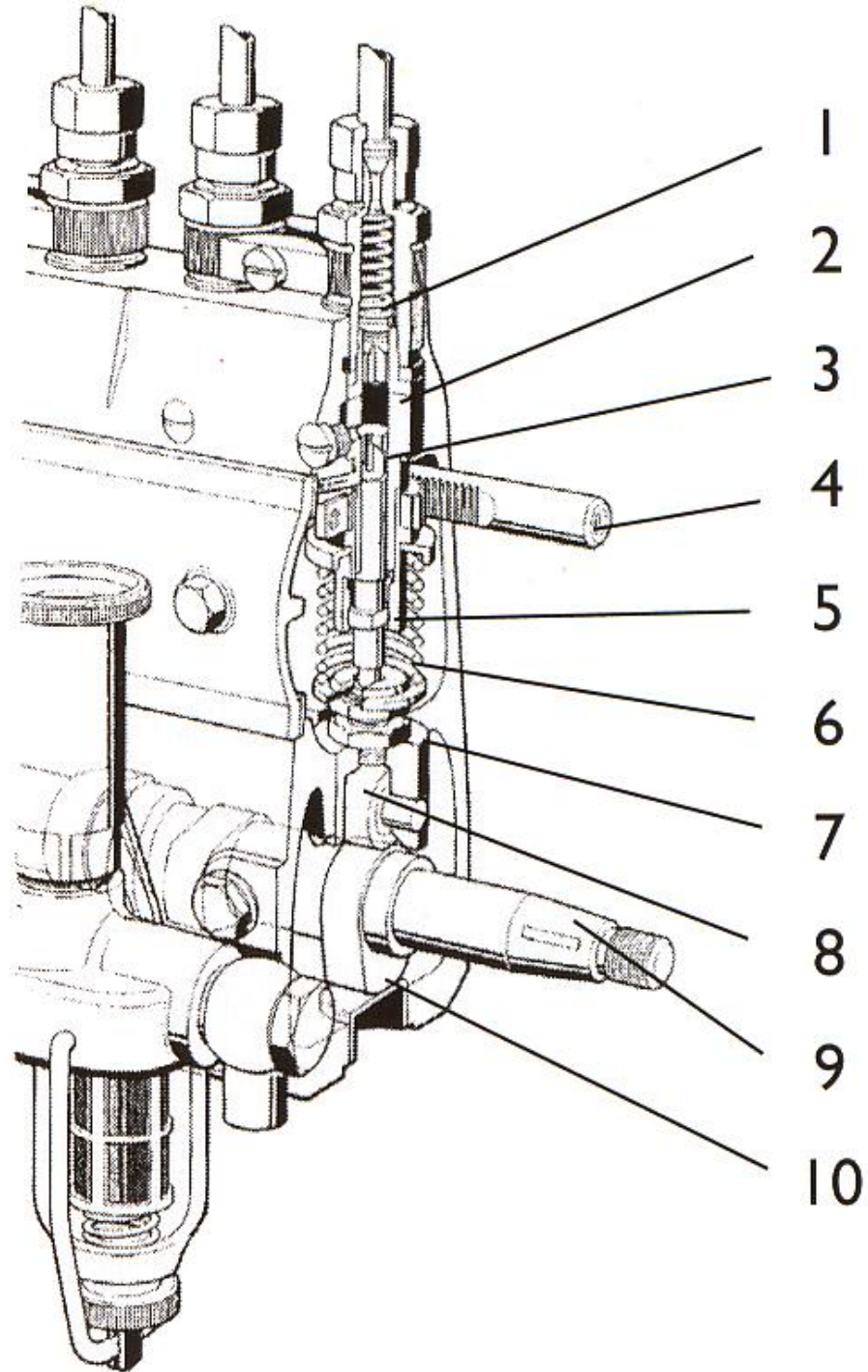

Dæluslagið mislangt

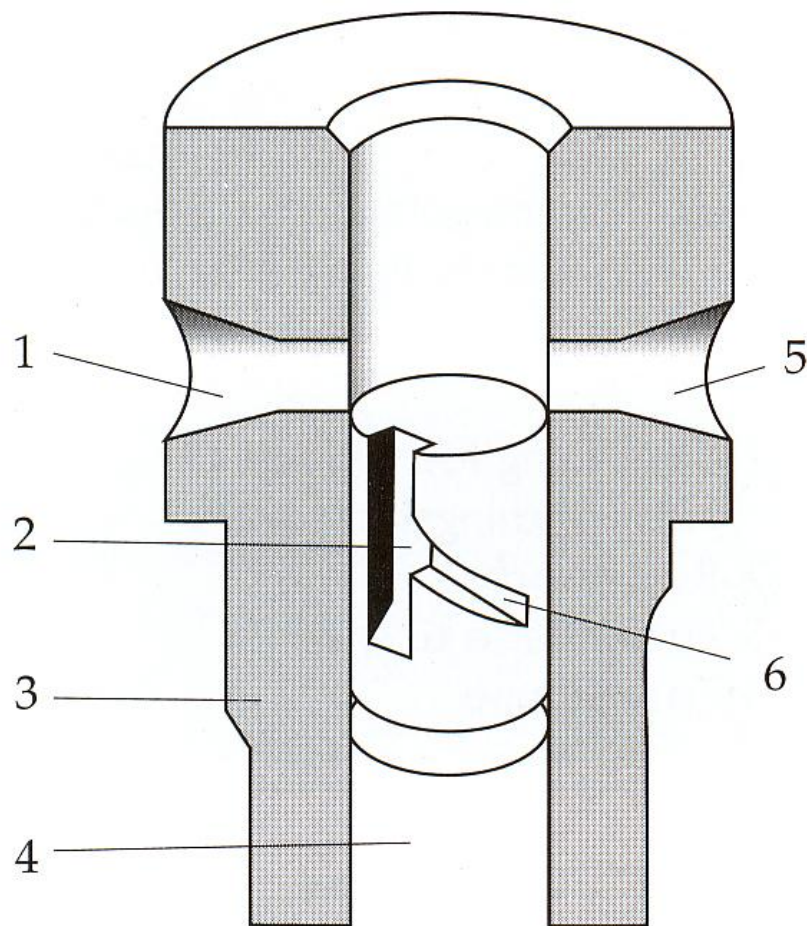

-
- Venjuleg dæla af gamla laginu

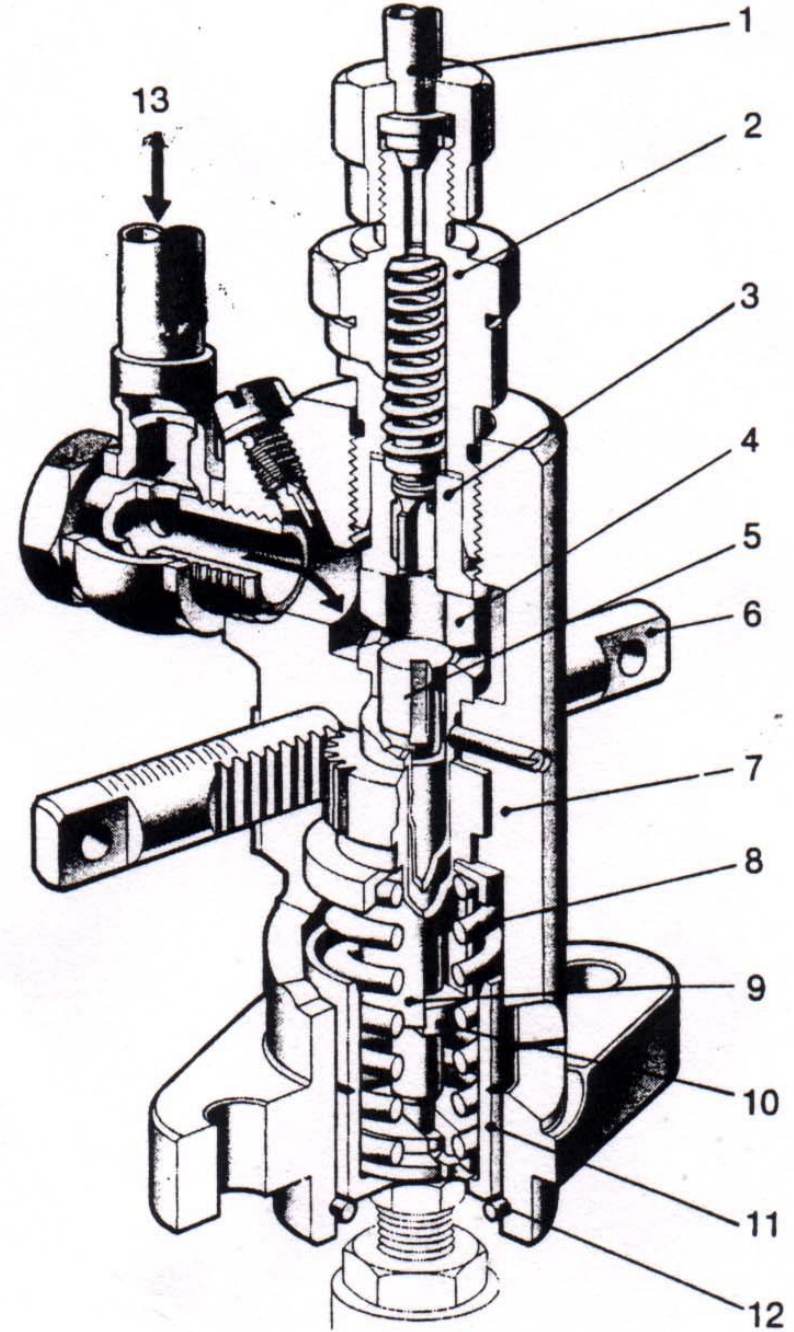

Dælar með snúningsbullu

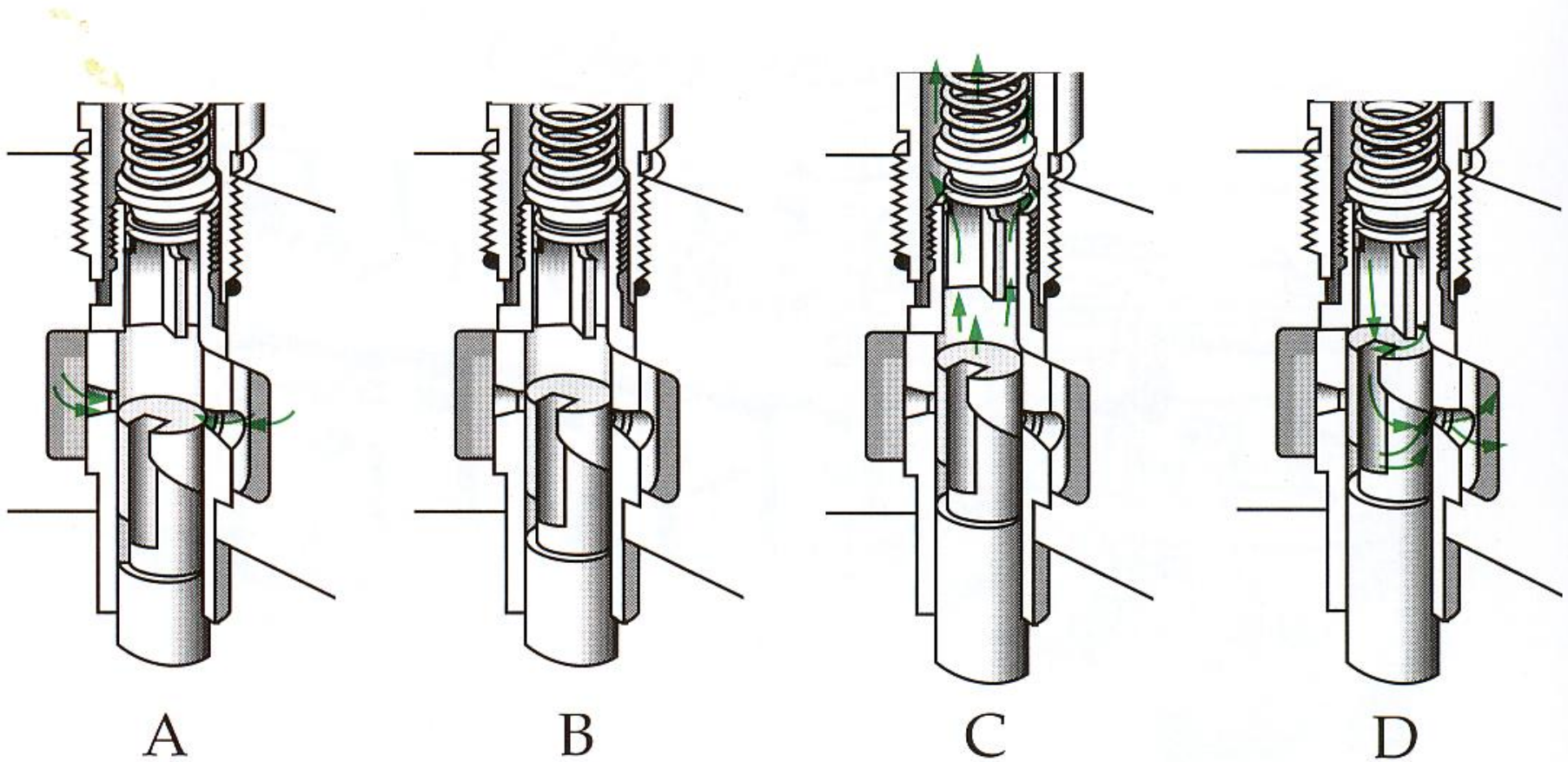

Fleiri dælar

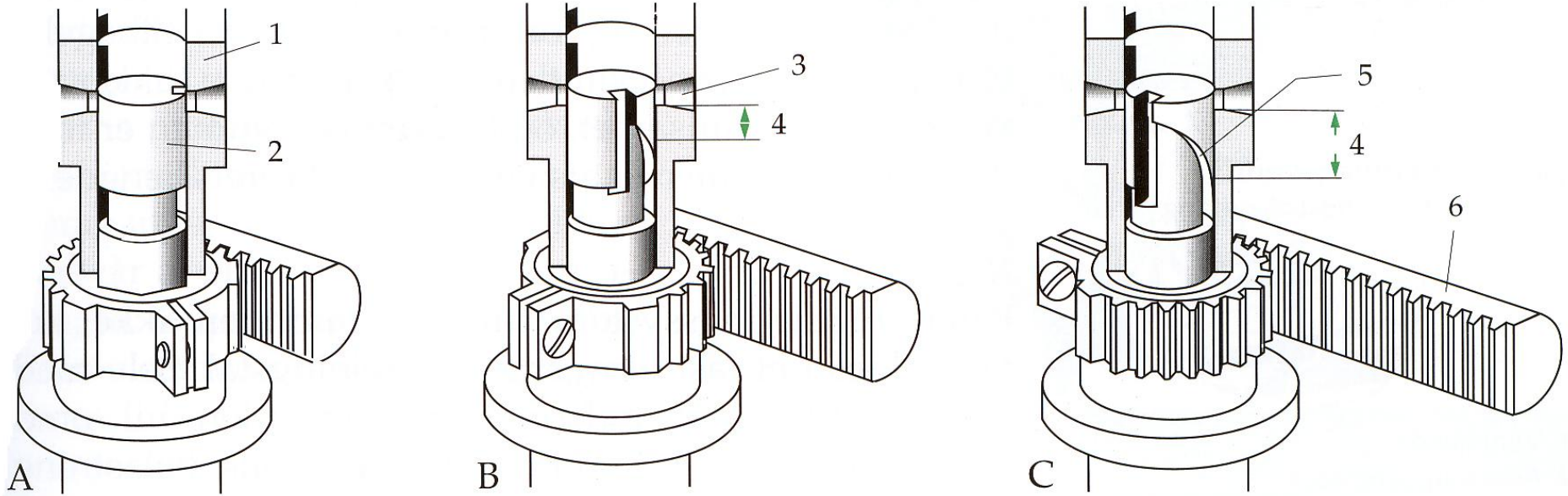

Þrýsti – eða afþrýstiloki í dælu

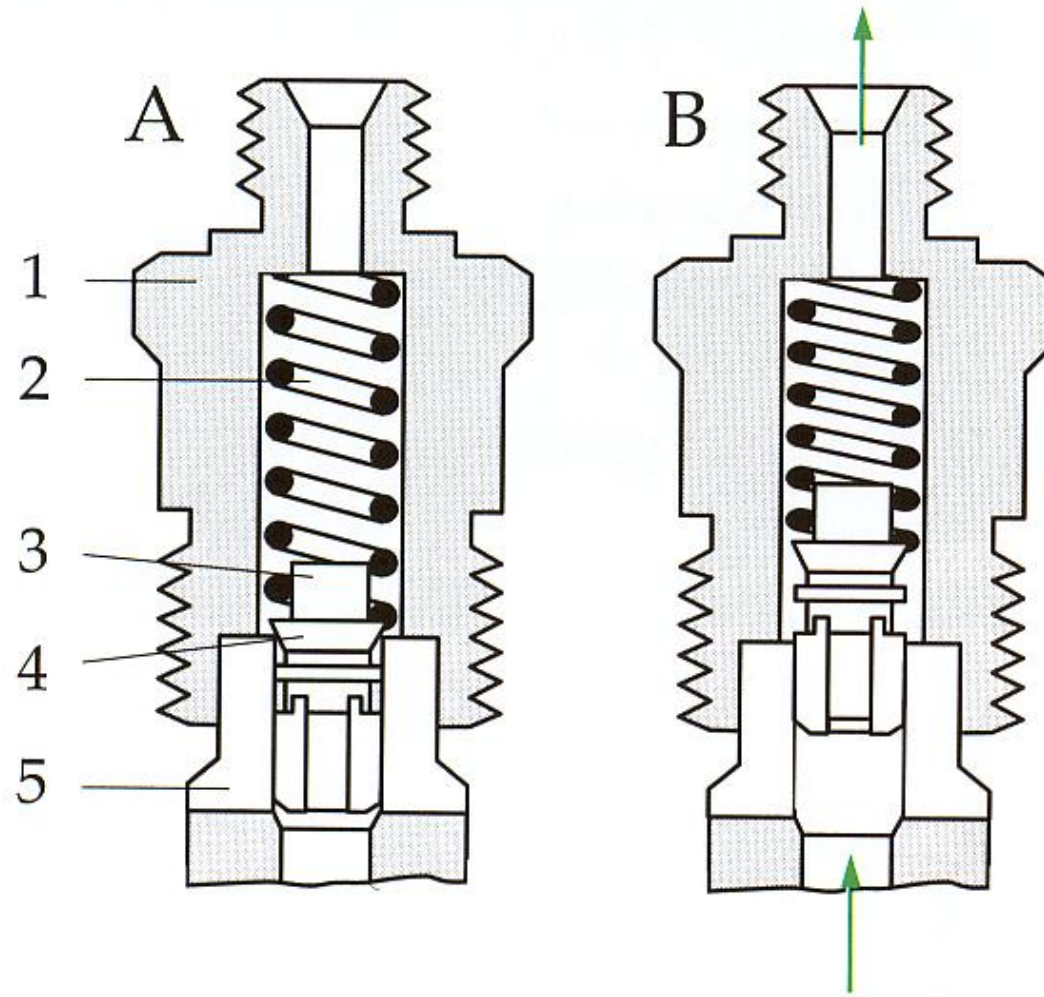

Fæðidæla

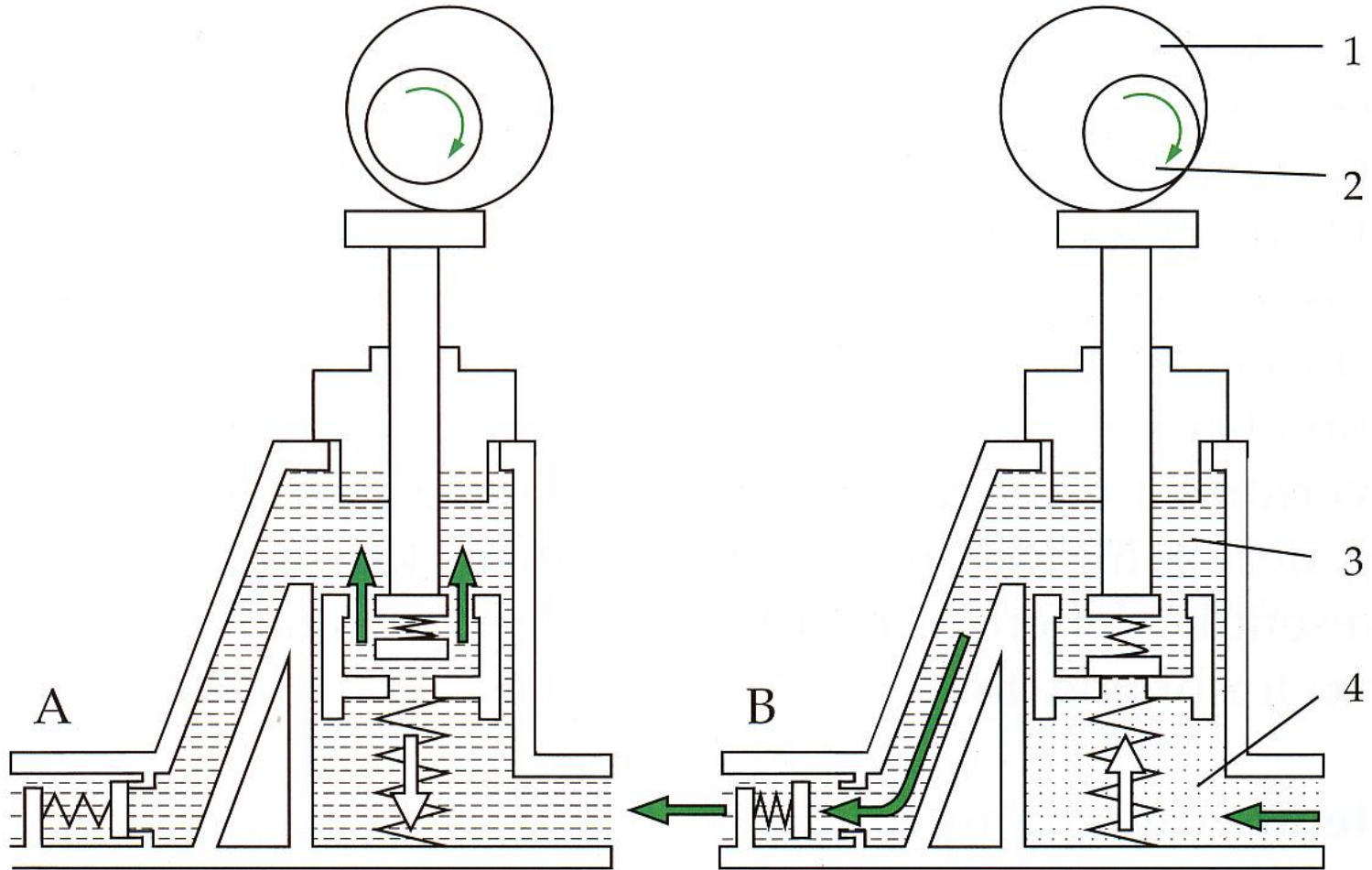

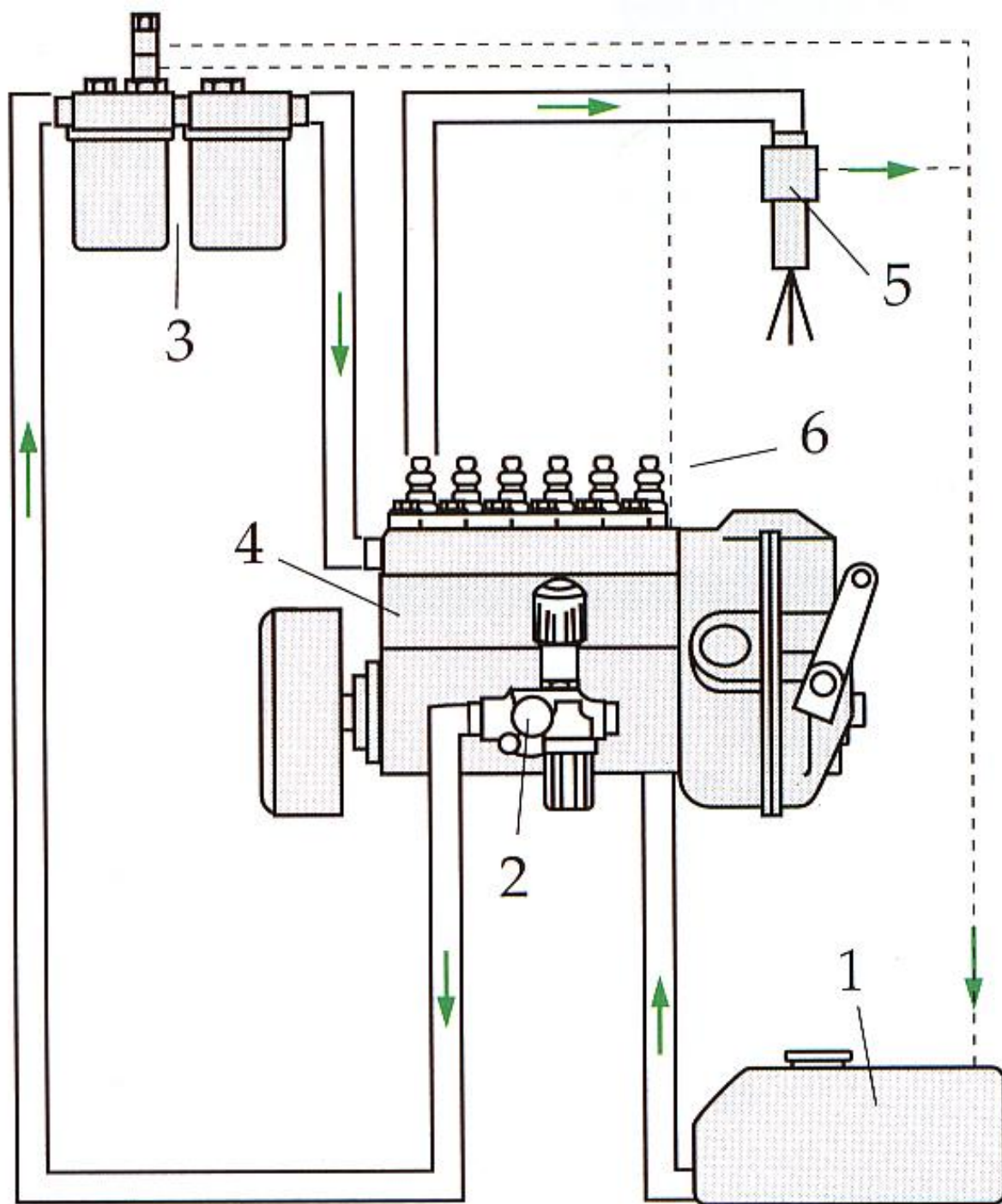

Eldsneytissíur

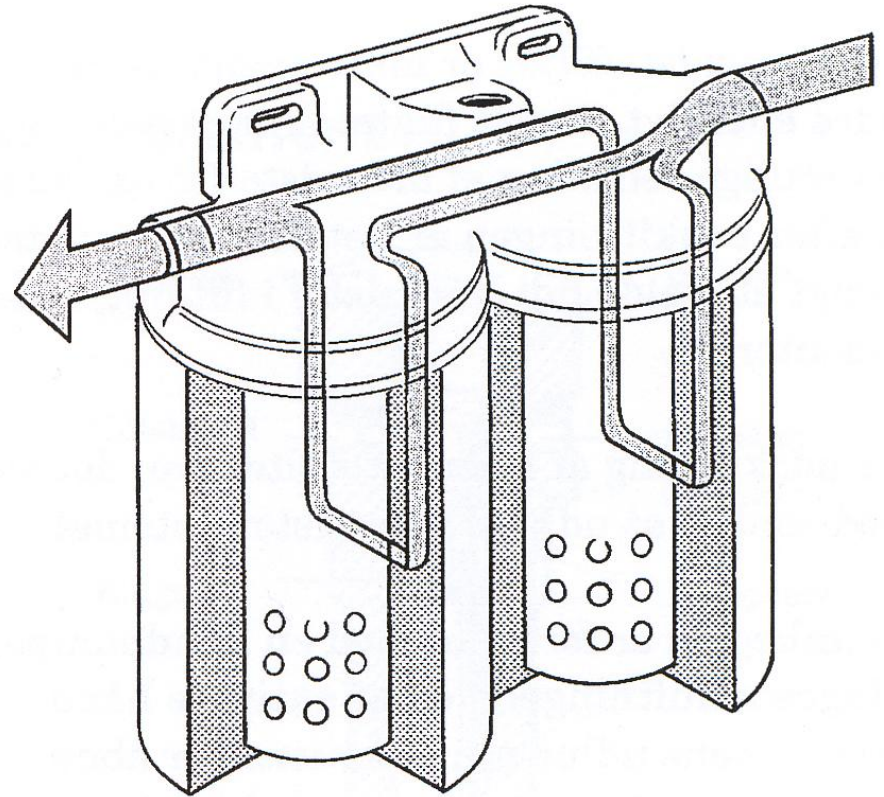
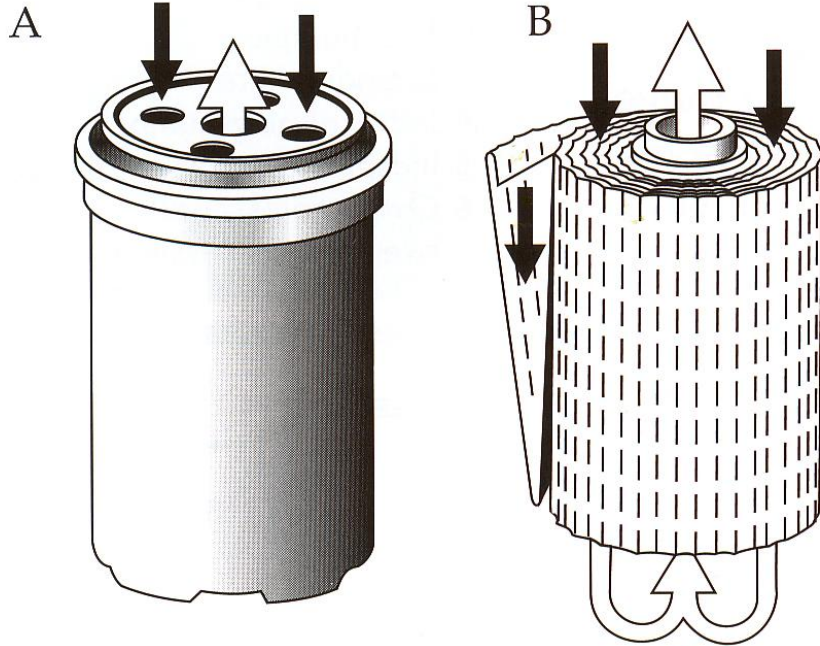

Síur með vatnsskiljur

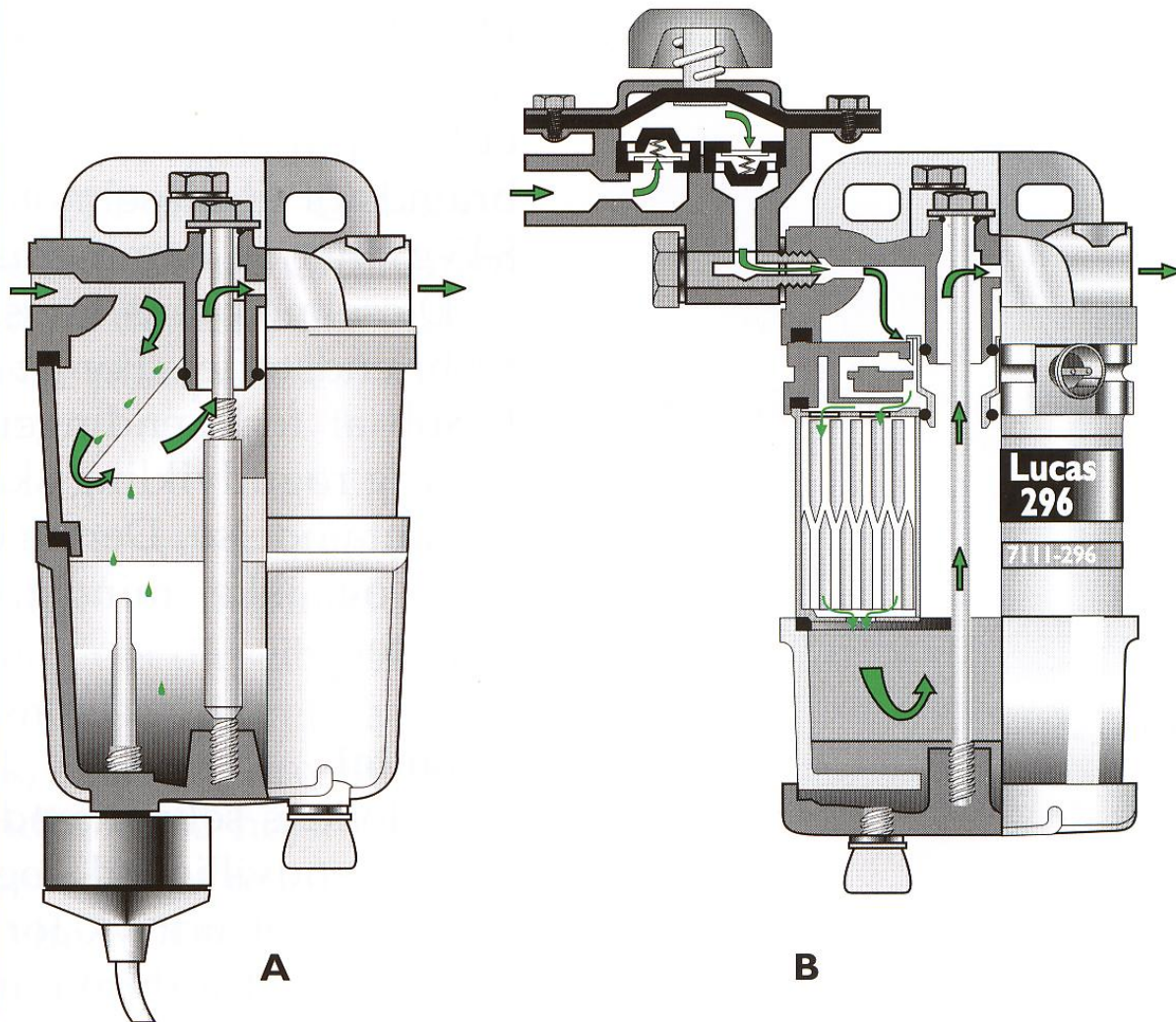

Deilíolíuverk

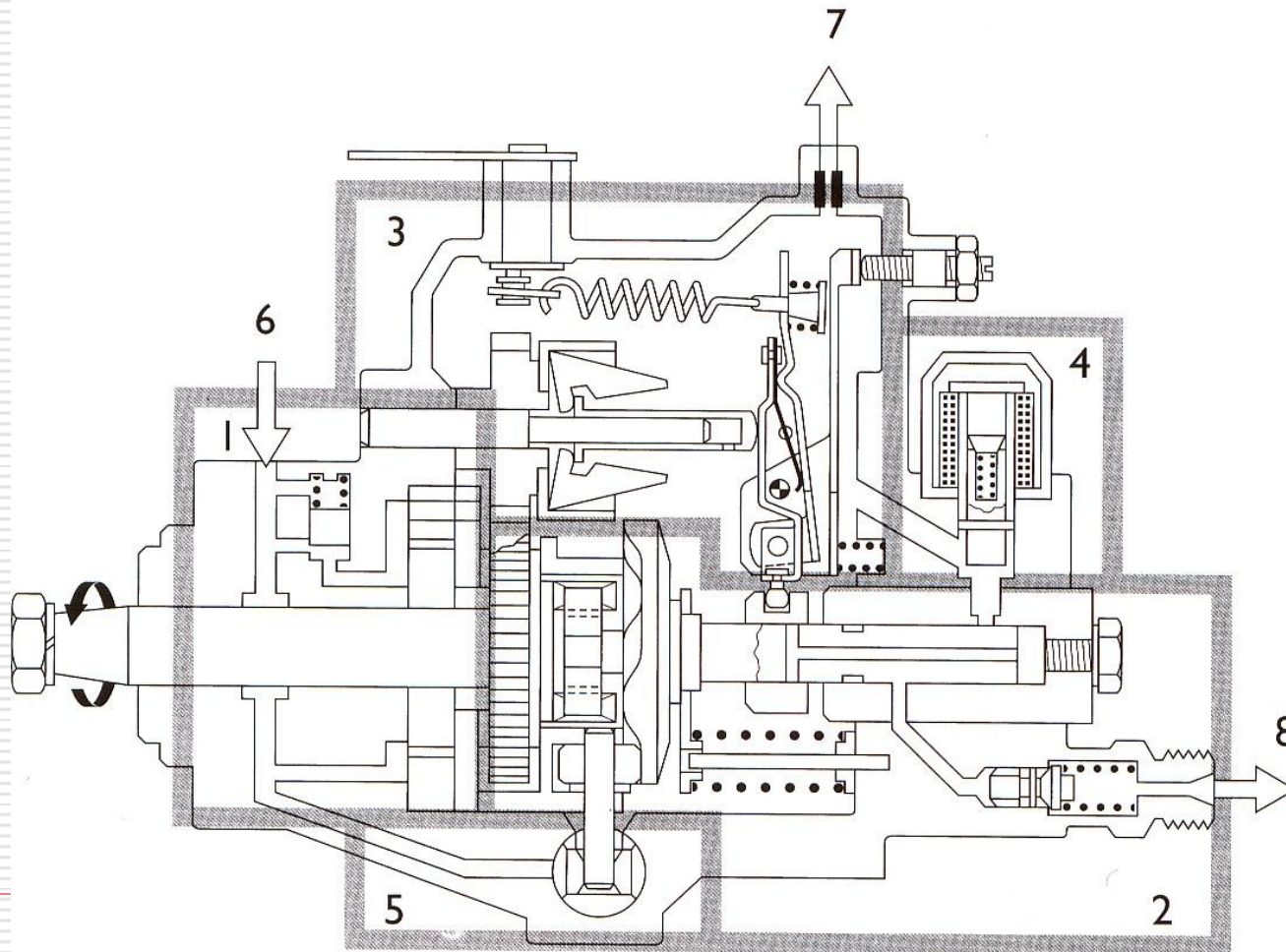

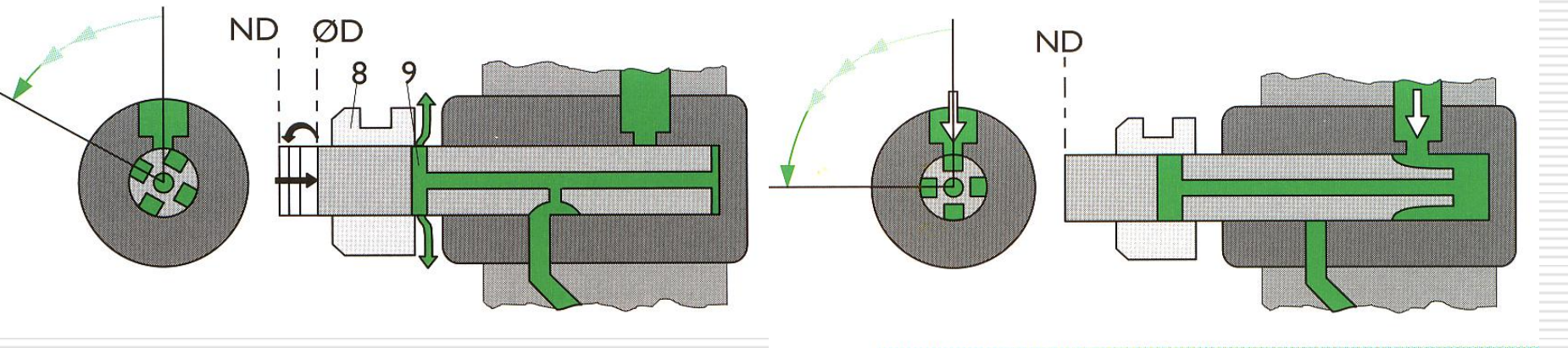
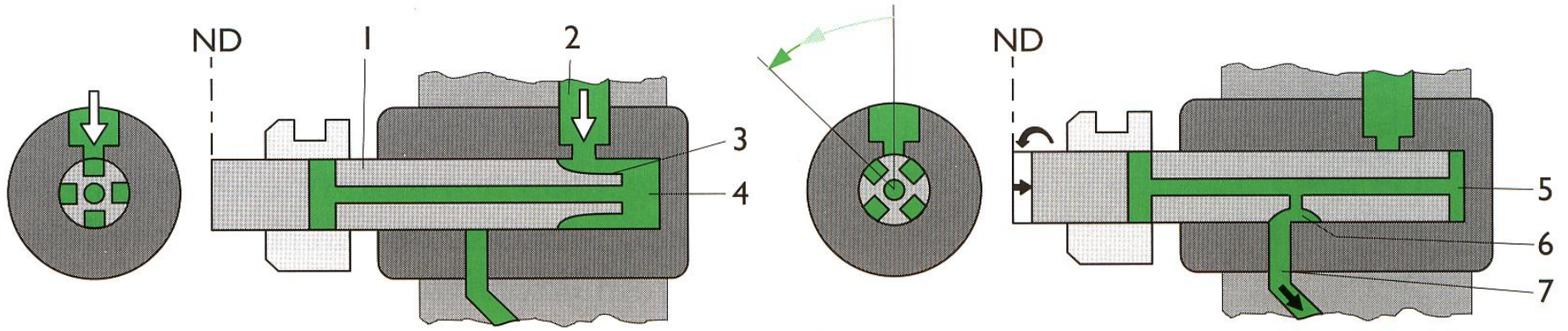

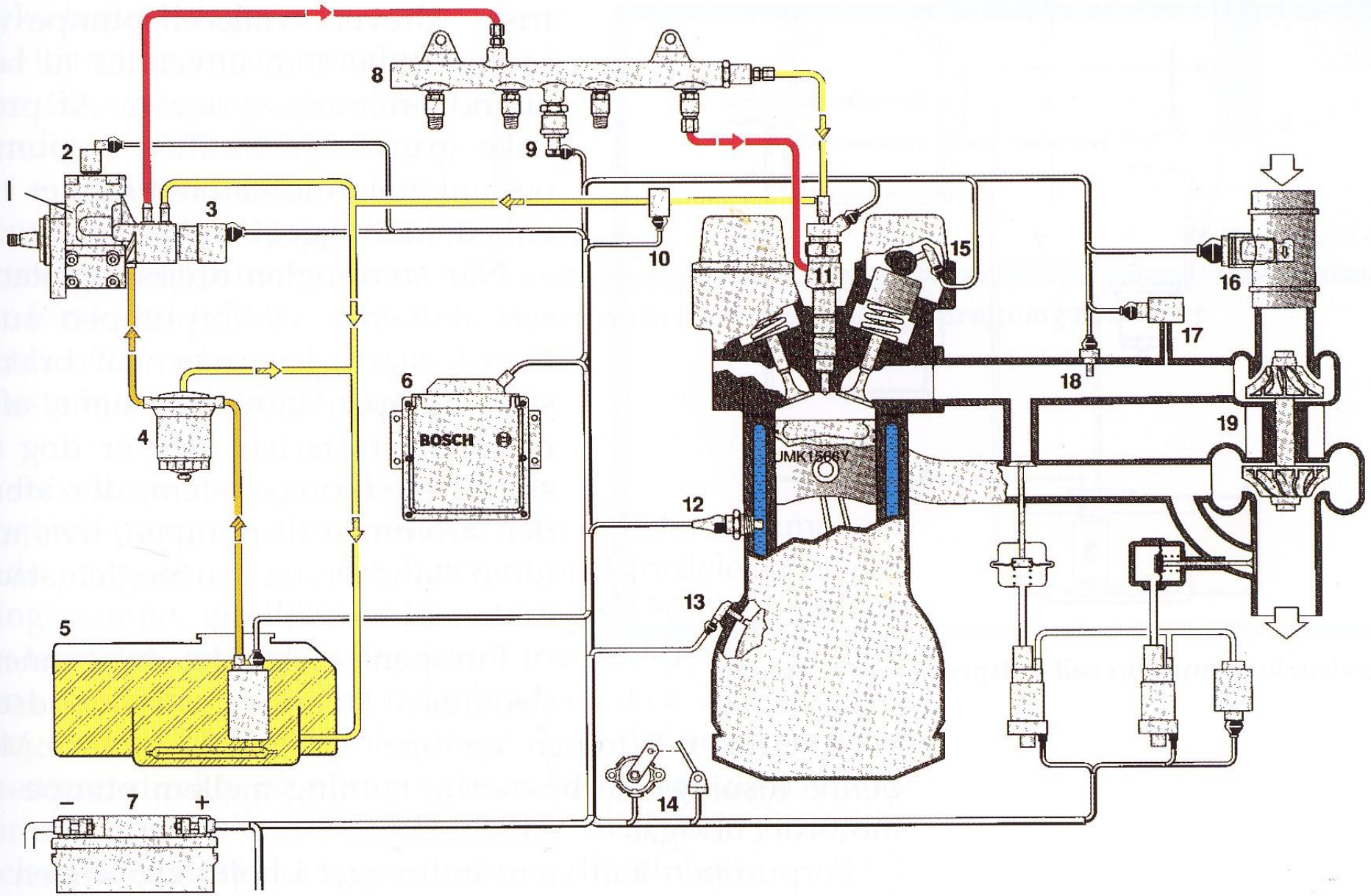

Guðmundur Einarsson

Spiss

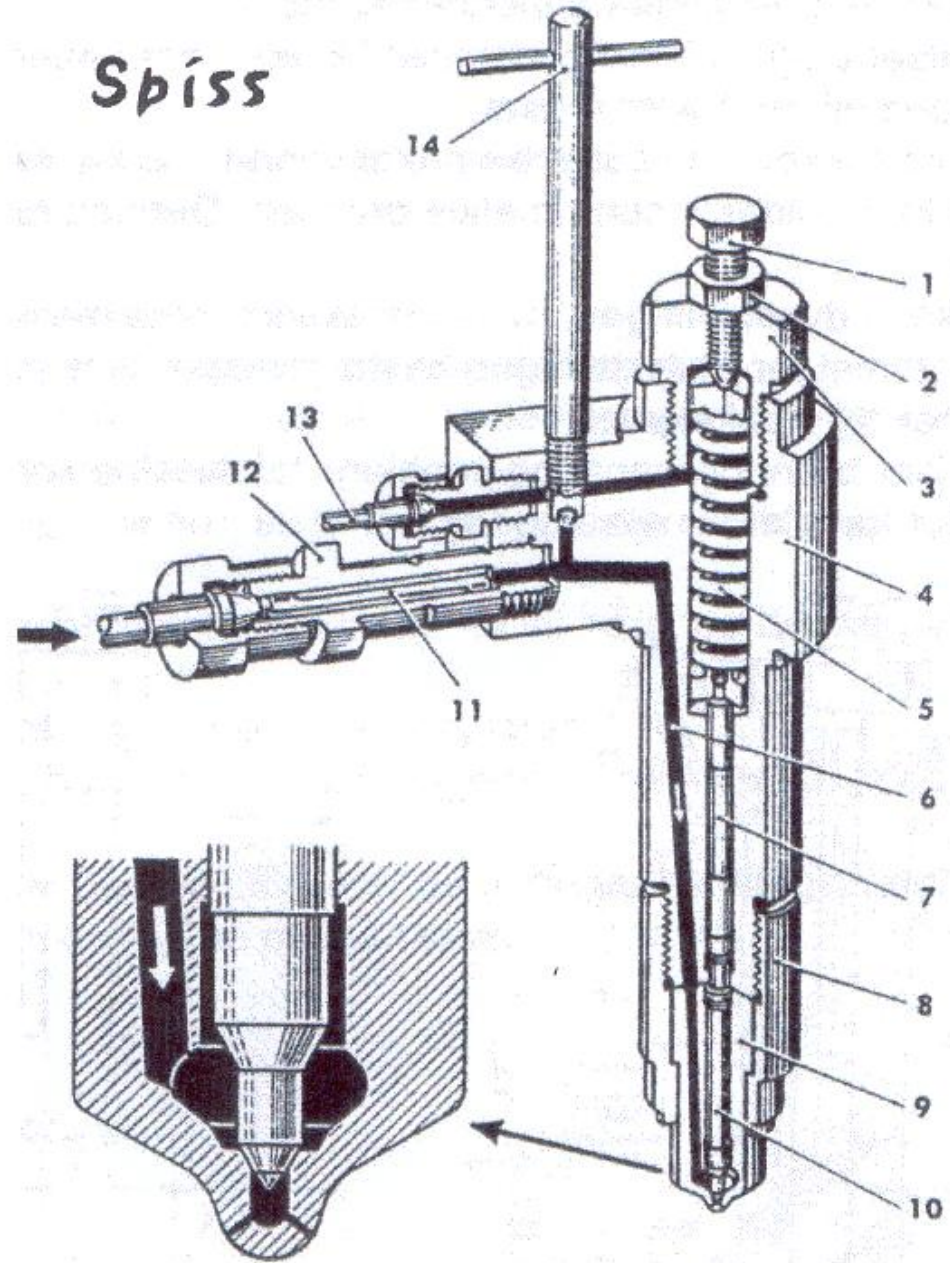

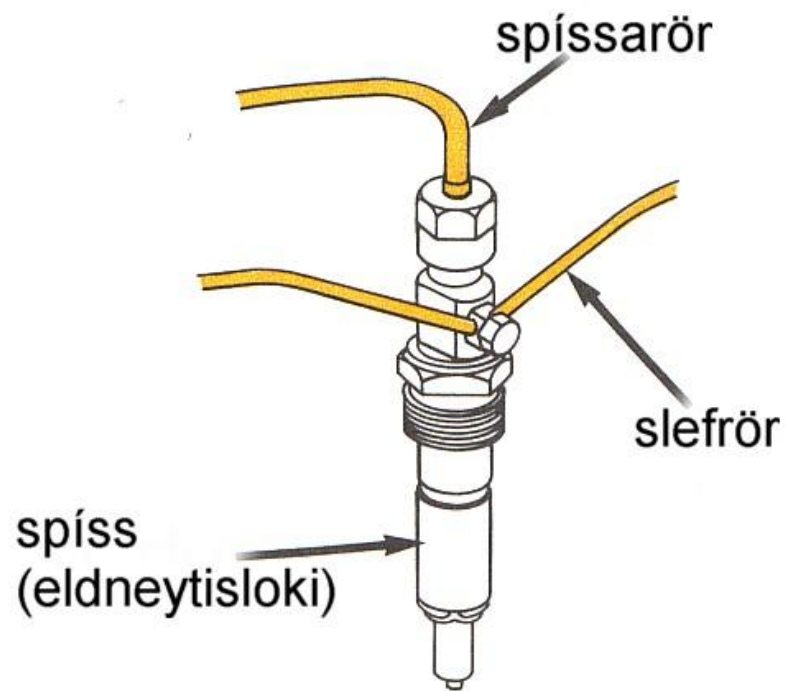
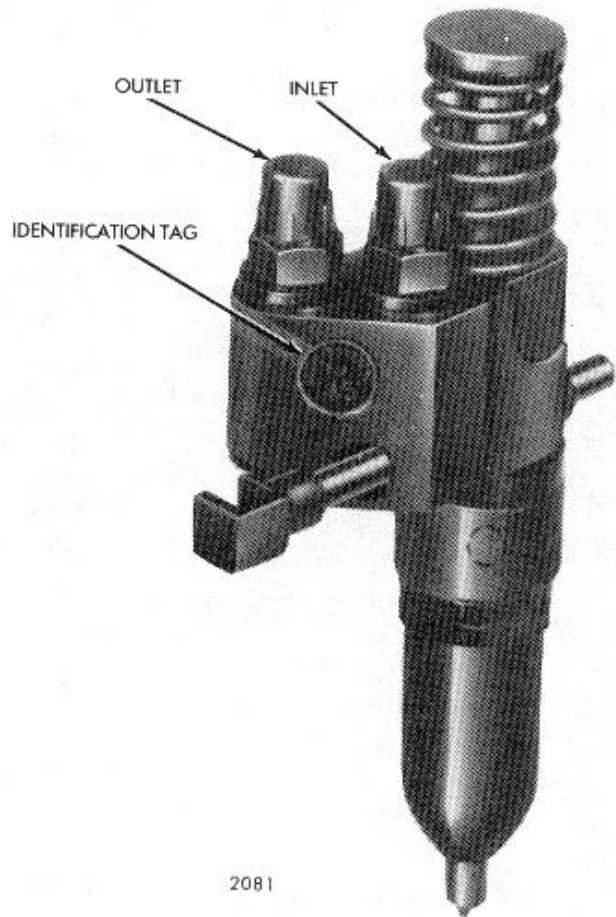

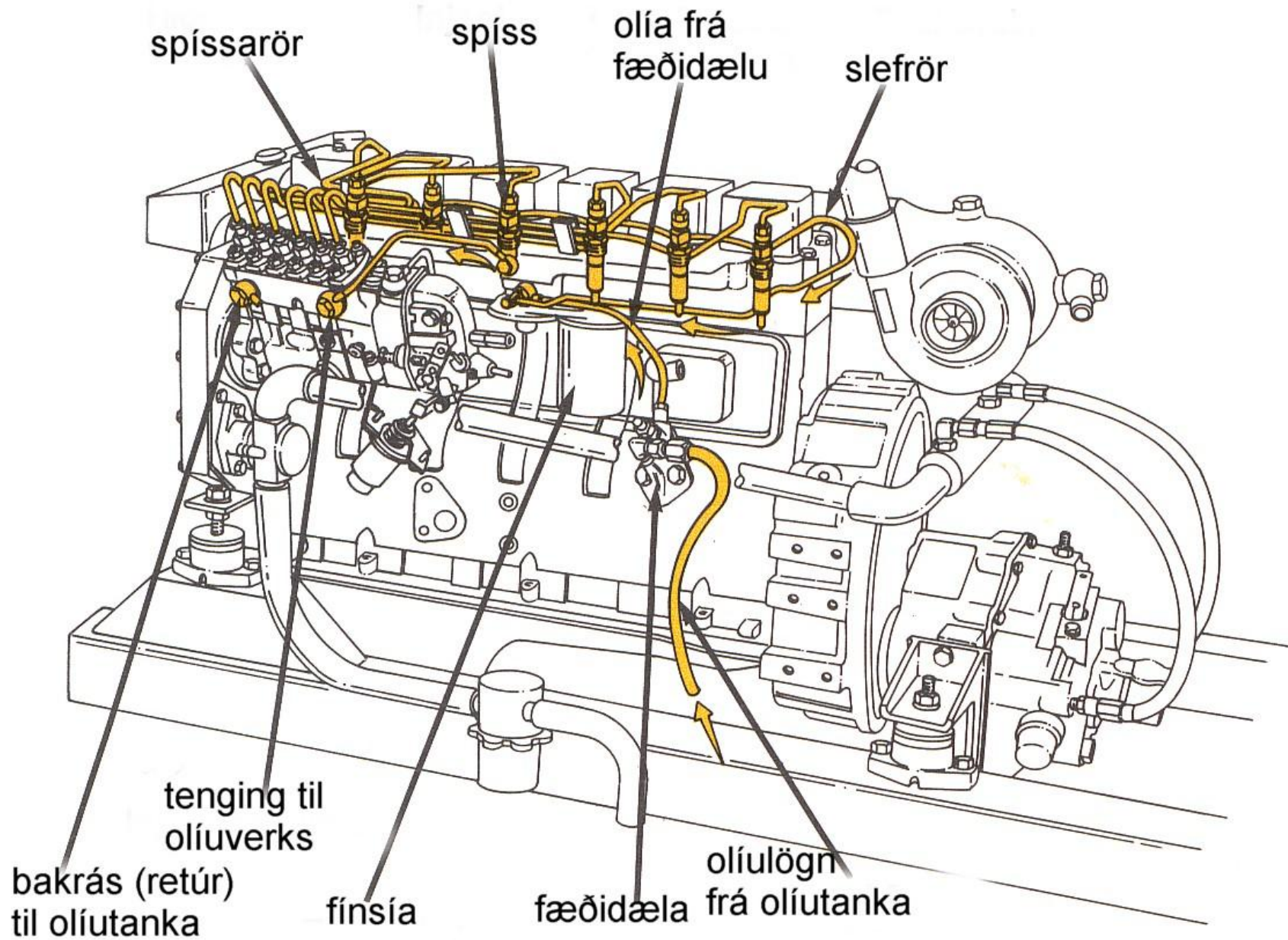

Allir verða að vita um afloftun

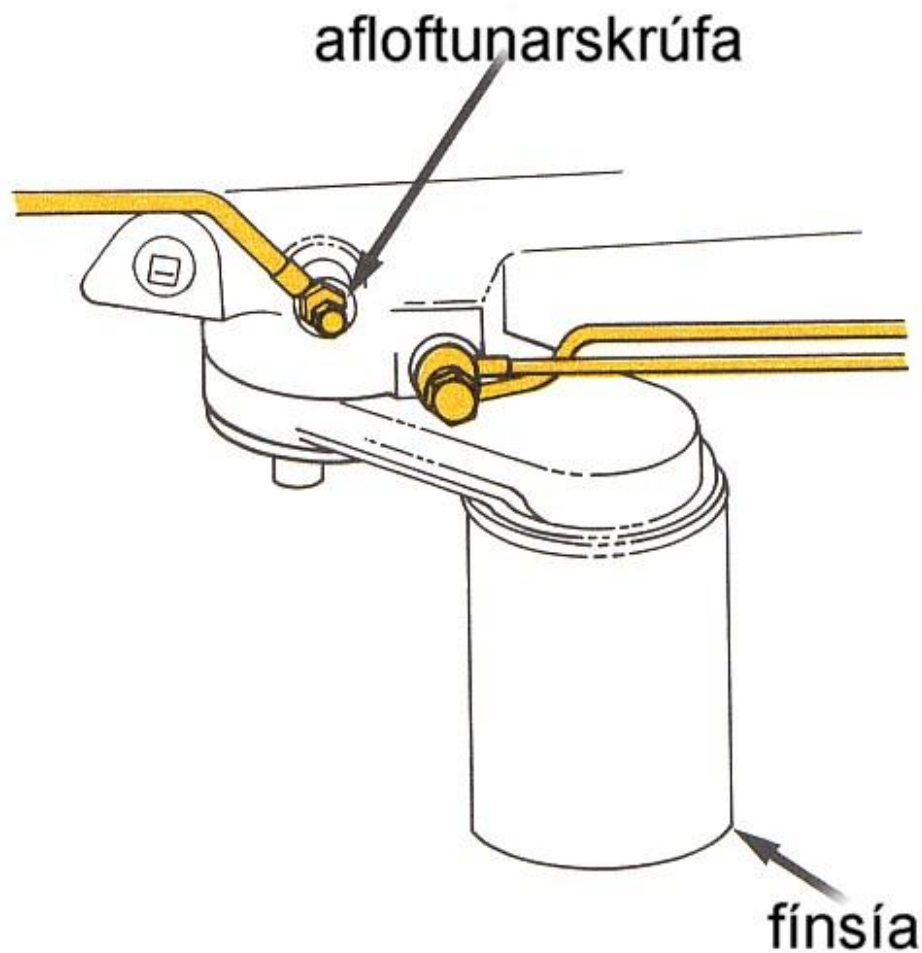

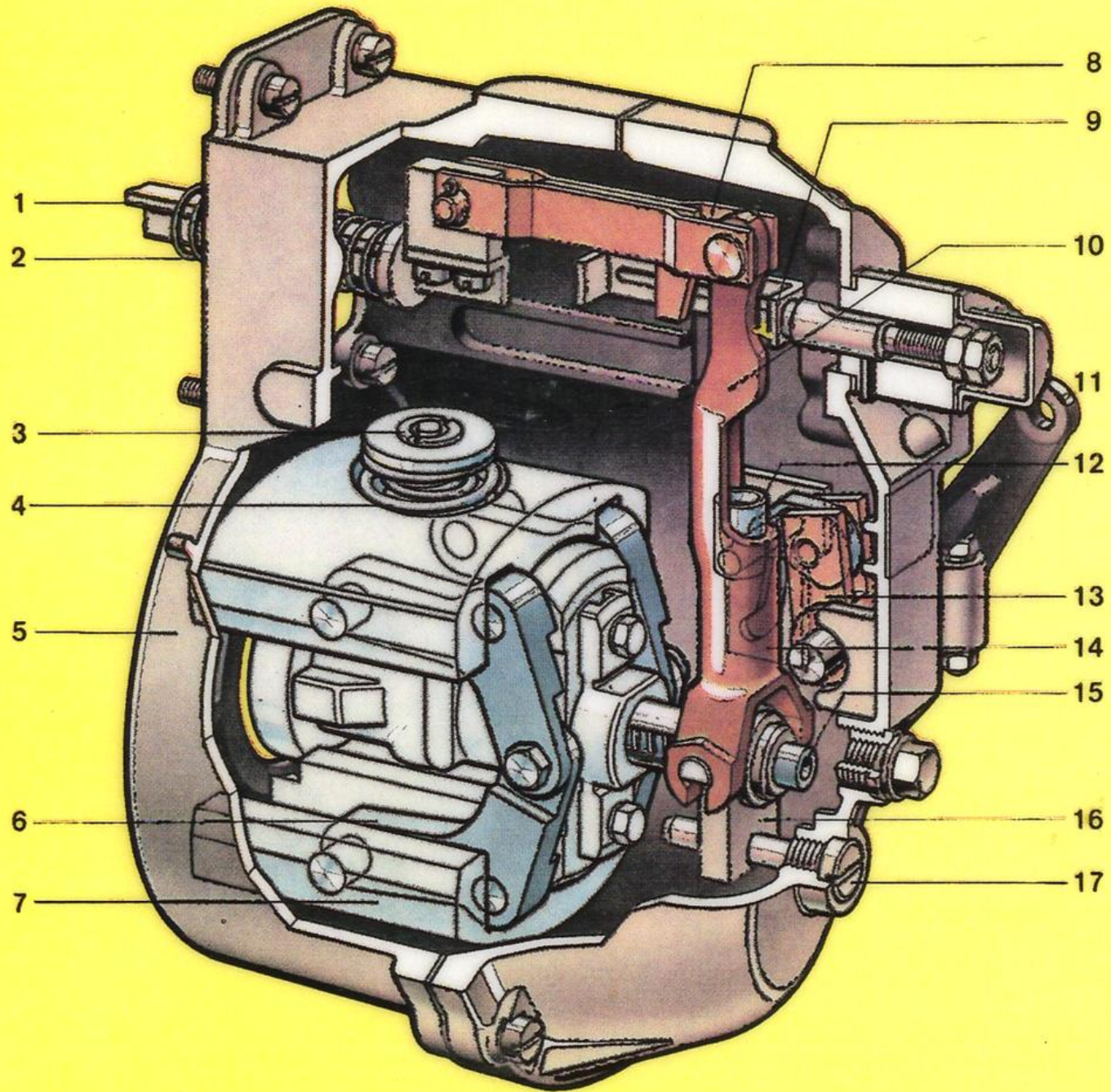

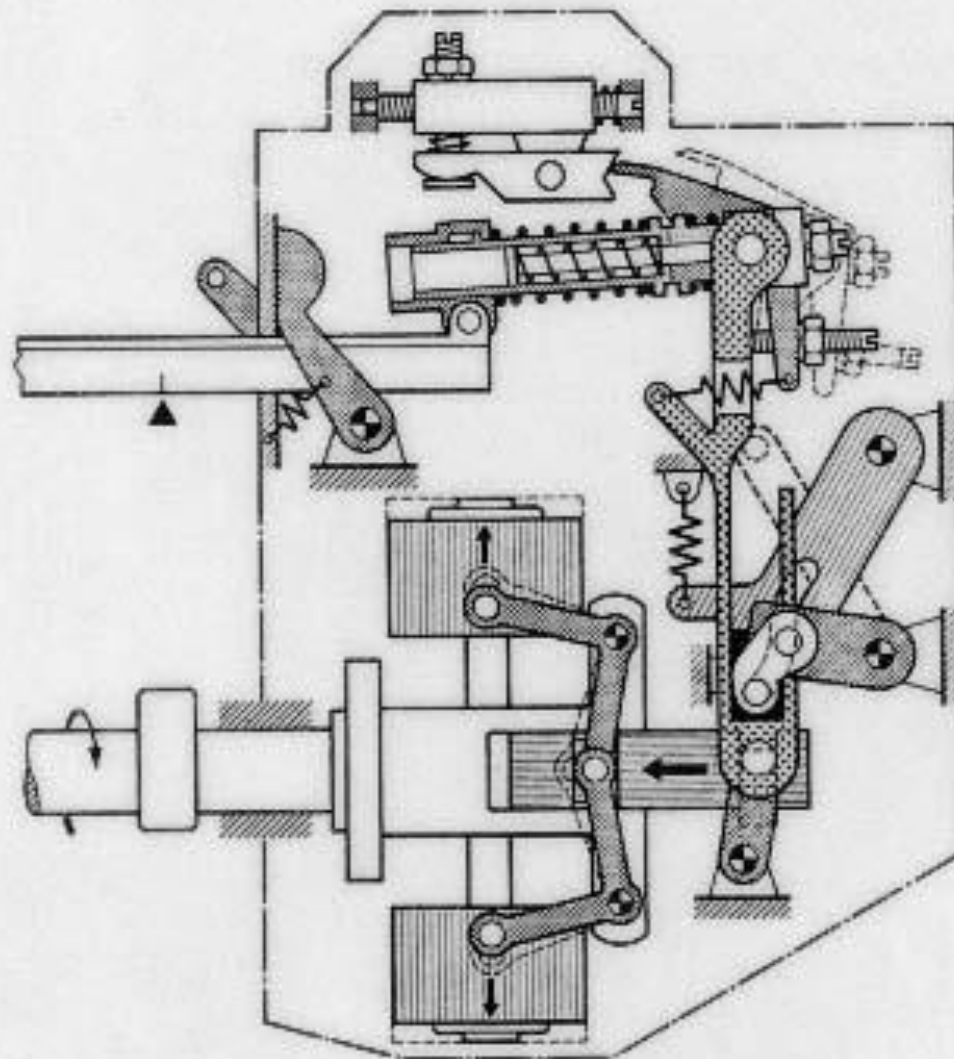

Maximum full load rotational speed

Kambásinn knýr dælu og ventil

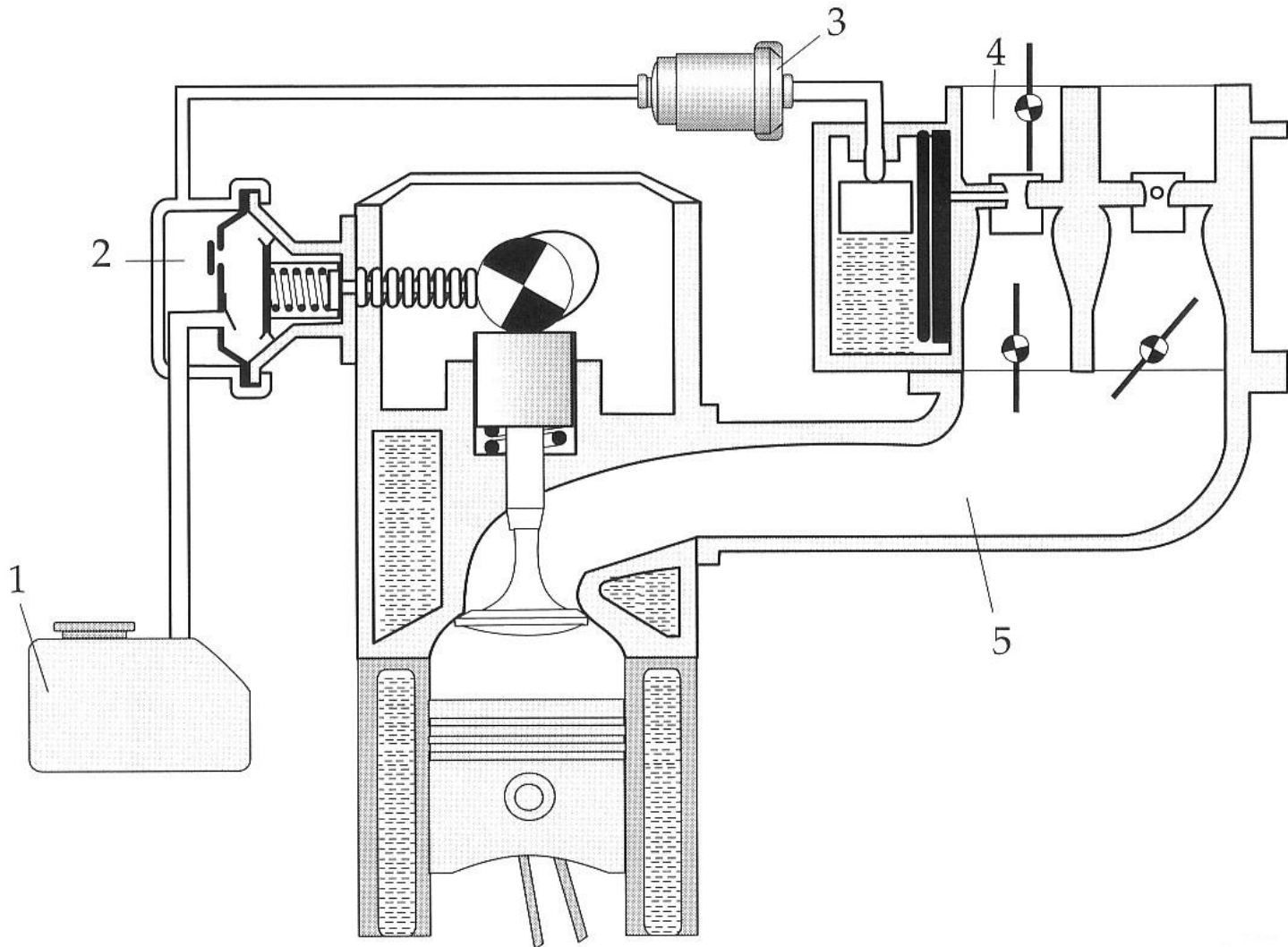

Þrengingin toga í bensínúðann

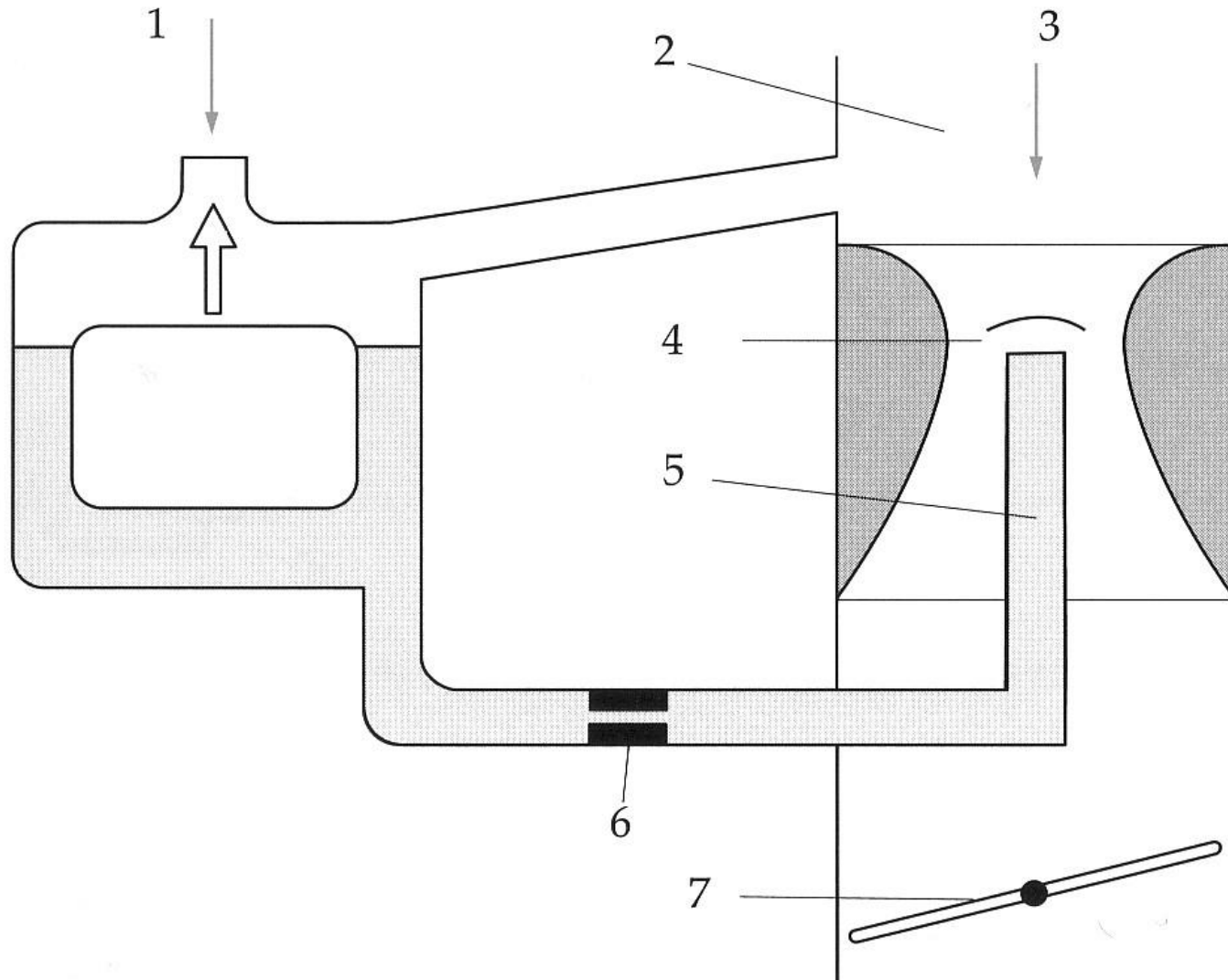

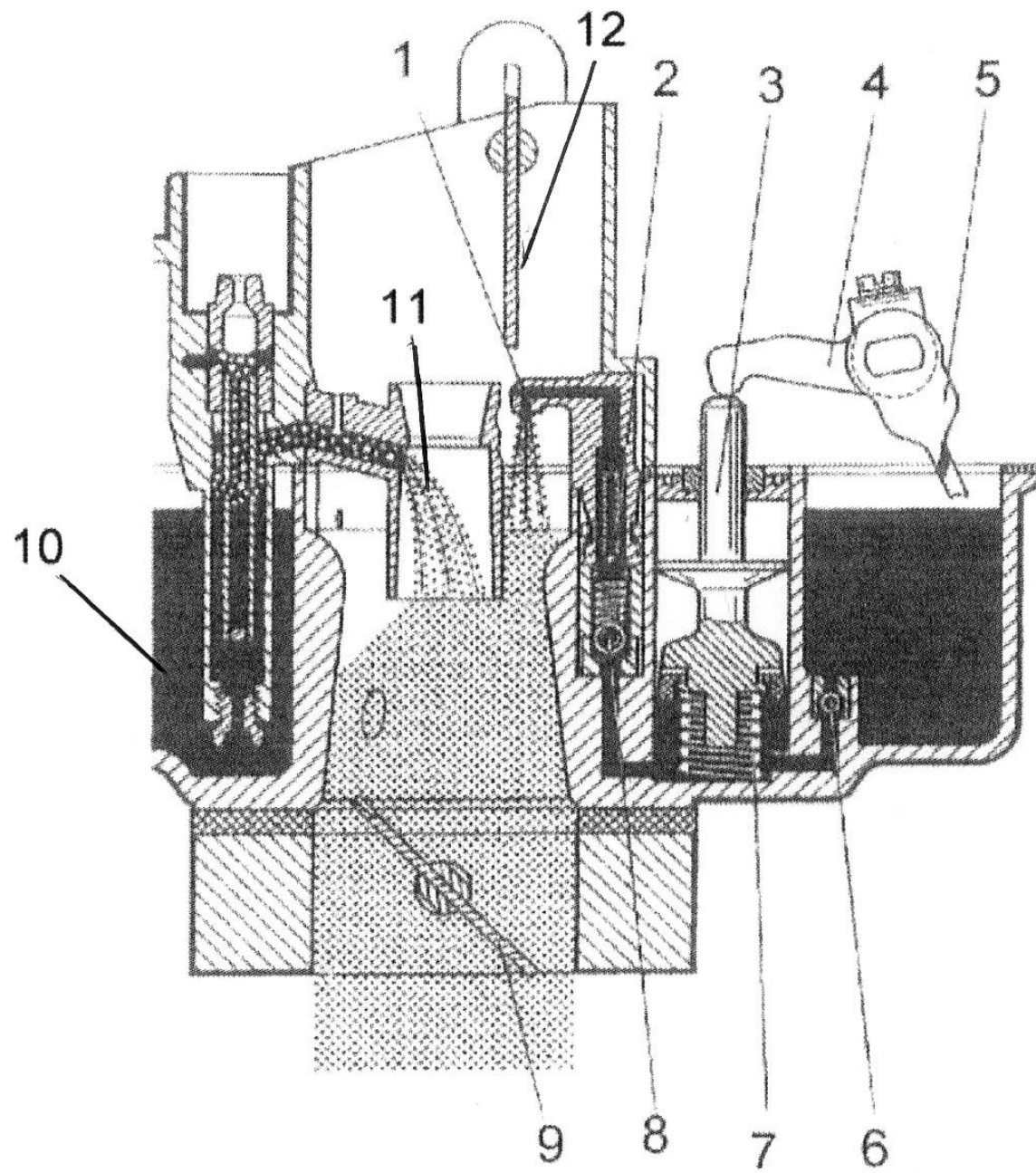

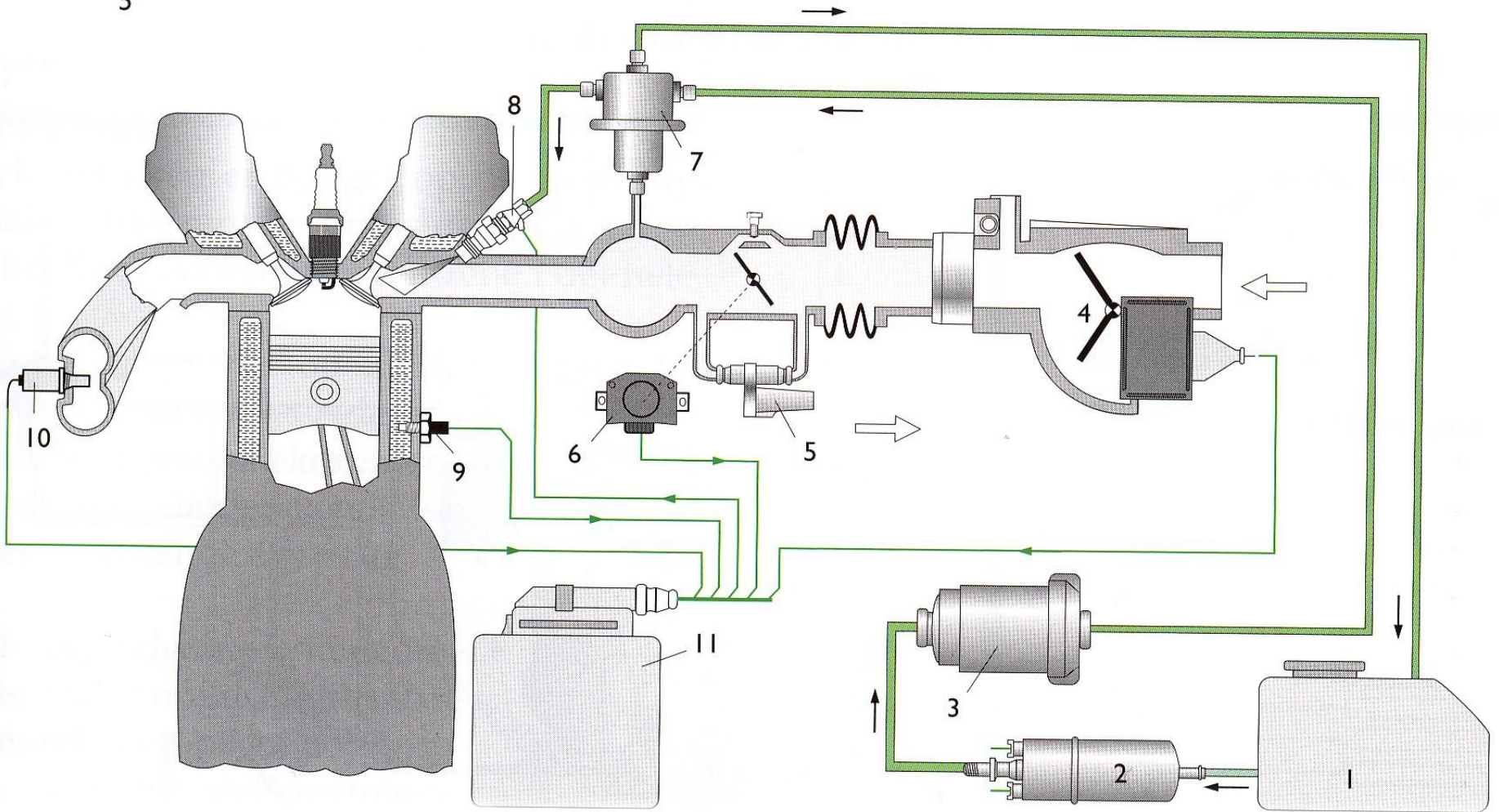
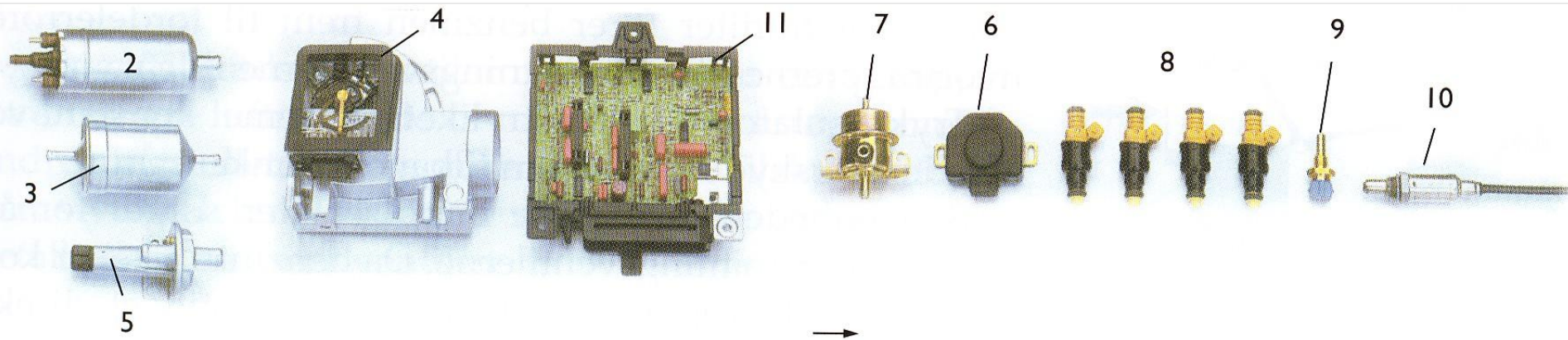

enginn þrýstingur

3 - 6,8 bar

50 - 100 bar

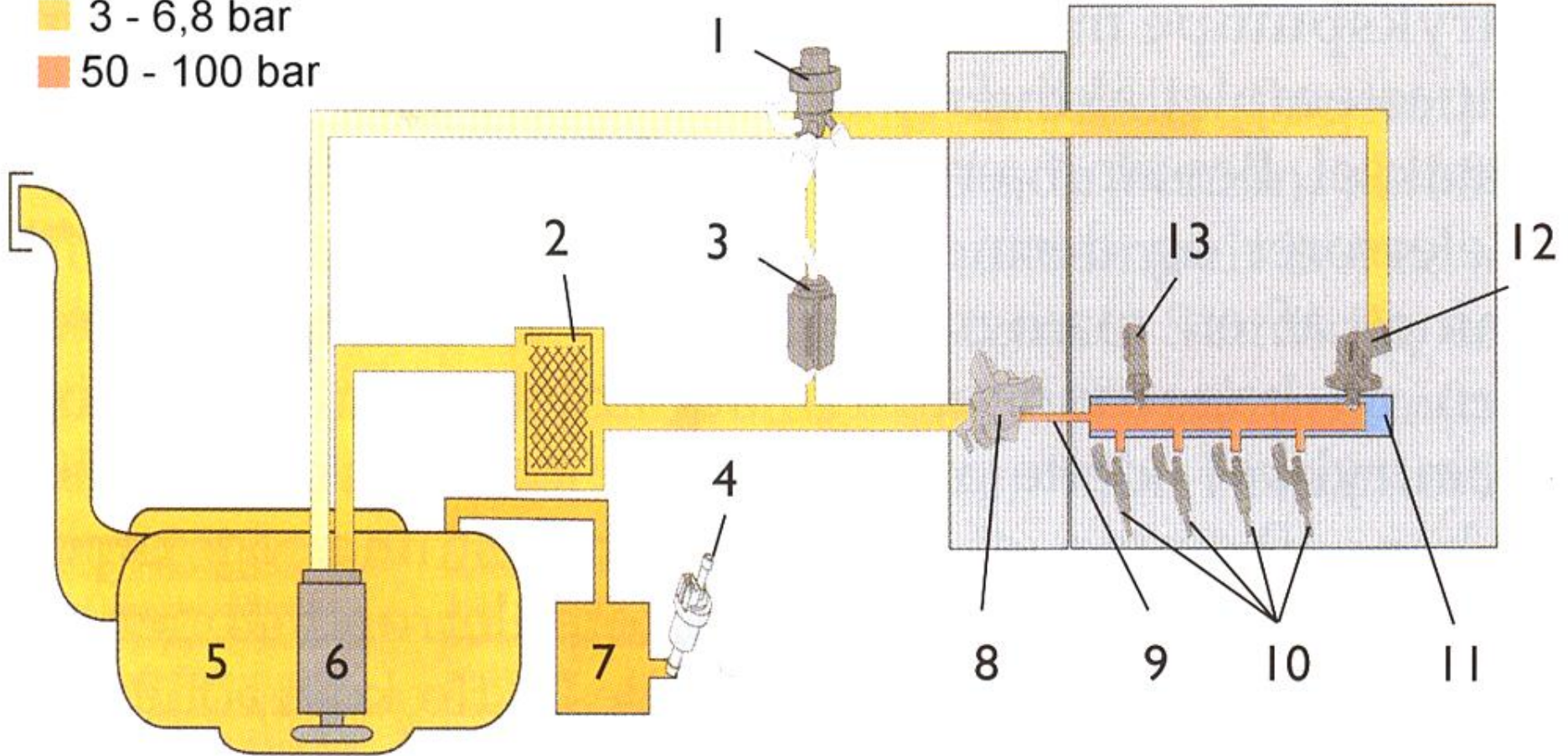

-
- Þarna er bensín
úðað inn í
brunaholið eins og
díselolía

